



argon[®]

2022-2023



Czas rozświetlić wnętrza!

Odkryj światło i blask rzemiosła

Ciesz się lampami ARGON

Doceniaj jakość i polską produkcję

Skoro trzymasz w ręku lub przeglądasz na ekranie ten katalog to jesteś na etapie poszukiwania oświetlenia do swoich wnętrz, ewentualnie odpowiadasz za wsparcie przy tych poszukiwaniach jako Sprzedawca lub Projektant. Zarówno nam, jak i Wam, niezależnie kim jesteście, zależy na jednym – rozświetlić wnętrza w nietuzinkowy sposób, tak aby cieszyły przez lata. Dlatego na kolejnych stronach znajduje się blisko 900 lamp wyprodukowanych w Polsce przez firmę ARGON.

Wertując kolejne strony zauważysz, że to różnorodne oprawy – duże, małe, wiszące, stojące, szklane, metalowe, a nawet mosiężne czy z pięknymi tkaninowymi abażurami. Każda lampa jest inna, a my w ofercie mamy ich ponad 900. Nasz asortyment to różnorodność stylów, szeroki wachlarz zastosowanych materiałów, to oświetlenie stworzone z myślą o Tobie i Twoim wnętrzu. Sprawdź jak powstają nasze lampy, znajdź te które ulokujesz w swojej przestrzeni, zamów je u jednego z naszych Partnerów i ciesz się blaskiem światła!



ARGON to firma produkująca lampy założona przez Zdzisława Tomzika.

Jesteśmy firmą rodzinną, choć młode pokolenie podpowiada, to za finalny kształt produktów odpowiada właściciel – który od ponad 40 lat jest związany z branżą oświetleniową, a od ponad 25 lat rozwija firmę ARGON od garażu po wieloetapową manufakturę oświetlenia.

Proces powstania lampy zaczyna się od projektu, choć w przypadku lamp ARGON nie zawsze jest to takie oczywiste. Czasem nowe modele to ewolucja już istniejących w naszej ofercie projektów. Nie mniej jednak każdego roku spędzamy przeważnie długie jesienne i zimowe wieczory na tworzeniu konceptów, prototypów, szkiców naszych lamp.

Choć jesteśmy przedsiębiorstwem lokalnym, chcemy nieść blask lamp do szerokiego grona Odbiorców, do Klientów ceniących sobie staranność opracowania detalu, klasę zastosowanych materiałów.



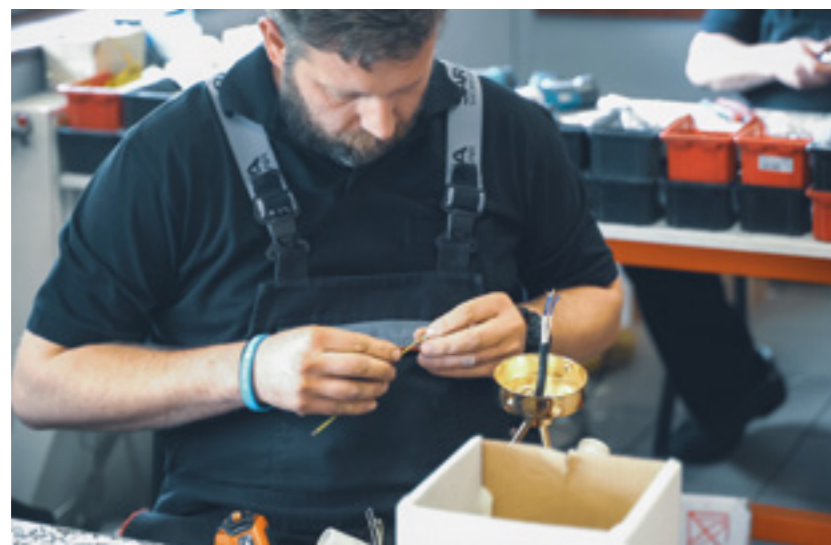

Na proces produkcyjny lampy składa się wiele etapów. W przypadku naszych opraw nic nie wydarzyłoby się bez ślusarni, to właśnie tam doświadczeni pracownicy parają się obróbką metali, przy czym wspiera ich w tym coraz nowocześniejszy park maszynowy. W ostatnich latach poszerzyliśmy wewnętrzny proces produkcyjny także o szlifiernię oraz lakiernię. W przypadku produkcji szklanych kloszy posiłkujemy się fantastycznymi działaniami naszych polskich hut, a eksperci od tkanin dostarczają nam abażury.

Małe śrubki, oprawki, przewody, tuleje, stelaże, podsufitki, klosze, abażury, włączniki same w sobie są tylko elementami. Istotnymi dla nas nawet bardzo, gdyż staramy się dbać o każdy detal. Jednak dopiero w całości sprawiają, że lampa wygląda tak jak w tym katalogu. Nie byłoby to możliwe bez naszych zespołów montażowych. Panie i Panowie od lat pracujący nad naszymi lampami, często znają je na pamięć i są w stanie z zamkniętymi oczami złożyć każdy model.

Nie możemy jednak zapomnieć o logistyce i dziale sprzedaży. Logistyka zaczyna się w dziale pakowania, gdzie każda lampa trafia do opakowania, jest zabezpieczana na czas transportu, wzbogacana o niezbędne akcesoria czy instrukcje. Magazynierzy rozmieszczają lampy na półkach, ale najczęściej lampa wprost z produkcji trafia na palety lub do pojedynczych paczek do wysyłki. Jako manufaktura oświetlenia nie produkujemy lamp na zapas, staramy się nie marnować zasobów – nasze lampy są tworzone specjalnie dla Ciebie, dlatego wybac, że czasem musisz na nie poczekać nieco dłużej. Choć robimy co możemy. Natomiast nasz dział sprzedaży dba nie tylko o aktualną sprzedaż, ale właśnie też o tę informację z produkcji, kwestie doradcze i obsługę posprzedażową.

Wiedz, że możesz na nas liczyć i będziemy się starać pomóc z Twoją lampą nawet po wielu latach od zakupu!



Z CZEGO POWSTAJĄ LAMPY ARGON

Różnorodna stylistyka lamp, szeroki wachlarz wariacji sprawia, że oferujemy lampy z bardzo wielu materiałów: szkła, aluminium, stali, litego mosiądzu. Stal i aluminium najczęściej są lakierowane, chromowane lub też otrzymują mosiądzowaną powłokę w procesie galwanizacji. W oprawach oświetleniowych ARGON wykorzystujemy też szkło gładkie przezroczyste, opalowe, barwione, w tym mleczne, a także szkło kryształowe. Wiele lamp wyposażonych jest także w tkaninowe abażury – co istotne to atestowane materiały przeznaczone do użytku w lampach. Kilka z naszych opraw wykonanych jest z drewna, w tym przypadku również dbamy o to, aby nie tylko spełniało wszystkie niezbędne normy, ale też zostało pozyskane z poszanowaniem dla środowiska. Aspekty dbania o przyrodę, dbania o naszą planetę, ale też człowieka, w tym lokalną społeczność i jednostki są dla nas ważne – chcemy w tych kwestiach robić coraz więcej i z każdym rokiem się doskonalić.

JAK JE SPRZEDAJEMY

Chcemy sprawić by nasze lampy lada moment stały się Twoimi lampami. Liczymy, że te kilka zdjęć i danych produktów będzie dobrym argumentem. Wierzmy, że jeśli przeglądasz ten katalog w salonie oświetlenia to przy Tobie są eksperci, którzy będą w stanie Tobie doradzić przy zakupie, a może nawet wskażą osobę, która pomoże przy ich montażu. Tak jak szeroki jest nasz asortyment, tak też szeroka jest lista naszych Dystrybutorów. Lampy ARGON zamówisz i często też zobaczysz w dziesiątkach punktów stacjonarnych w całej Polsce. Nabędziesz je też w licznych sklepach internetowych, w tym w popularnych marketplace'ach. Na końcu tego katalogu poznasz szczegóły dotyczące gwarancji, a jeśli jesteś odpowiedzialny za dystrybucję oświetlenia ARGON to pozyskasz inne praktyczne informacje. Jako zespół ARGON również jesteśmy do dyspozycji i wspieramy zarówno klientów hurtowych, inwestorów jak i klienta indywidualnego w procesie zakupowym.

DLACZEGO WARTO MIEĆ LAMPY ARGON

Jeśli powyżej nie znalazłeś argumentu za zakupem lamp ARGON, to kolejne setki stron tego katalogu na pewno pomogą podjąć decyzję. Niestety zdjęcia nie oddadzą nam puszystej faktury welurowego abażura ani zjawiskowego blasku podsufitki czy finezji klosza ze szkła kryształowego, a także solidności mosiężnego stelażu. Zdjęcia nie oddają też w pełni dbałości o detale. W drugiej dekadzie XXI wieku nie zawsze też jest szansa zobaczyć finalny produkt na żywo przed podjęciem decyzji zakupowej. Ręczymy jednak, że jakość naszych produktów jest czymś co je wyróżnia, jest czymś co sprawia, że warto wybrać właśnie te lampy. Projektując oprawy oświetleniowe stawiamy też na wzornictwo, które będzie ponadczasowe, pasujące do licznych aranżacji, takie które sprawi, że zakupione przez Ciebie lampy będą wisienką na torcie dla urządzonych wnętrz. Zakup produktu z polskiej manufaktury oświetlenia to pewne wyzbycie się anonimowości, masz pewność, że nie zrobił tego żaden robot gdzieś tysiące kilometrów stąd – po prostu na każdym etapie powstawania lampy zdobiącej Twoją przestrzeń pracowali ludzie często wkładający nie tylko trud, ale też serce do zwieńczenia tego produktu.

Katalog ma być przewodnikiem po produktach – dzięki zdjęciom, rysunkom technicznym oraz podstawowym danym. W dobie Internetu to właśnie w sieci znajdziesz więcej zdjęć naszych produktów, Projektanci wnętrz znajdą modele 3D lamp, a Partnerzy handlowi dostęp do panelu B2B z którego będą mogli dla Ciebie zamówić lampy – zapraszamy na naszą stronę argon-lampy.pl.

Każdego też zapraszamy i zachęcamy do kontaktu z nami mailowo i telefonicznie, będziemy starać się podpowiedzieć i odpowiedzieć na nurtujące pytania.

Przeglądaj, wybieraj i ciesz się blaskiem lamp ARGON!

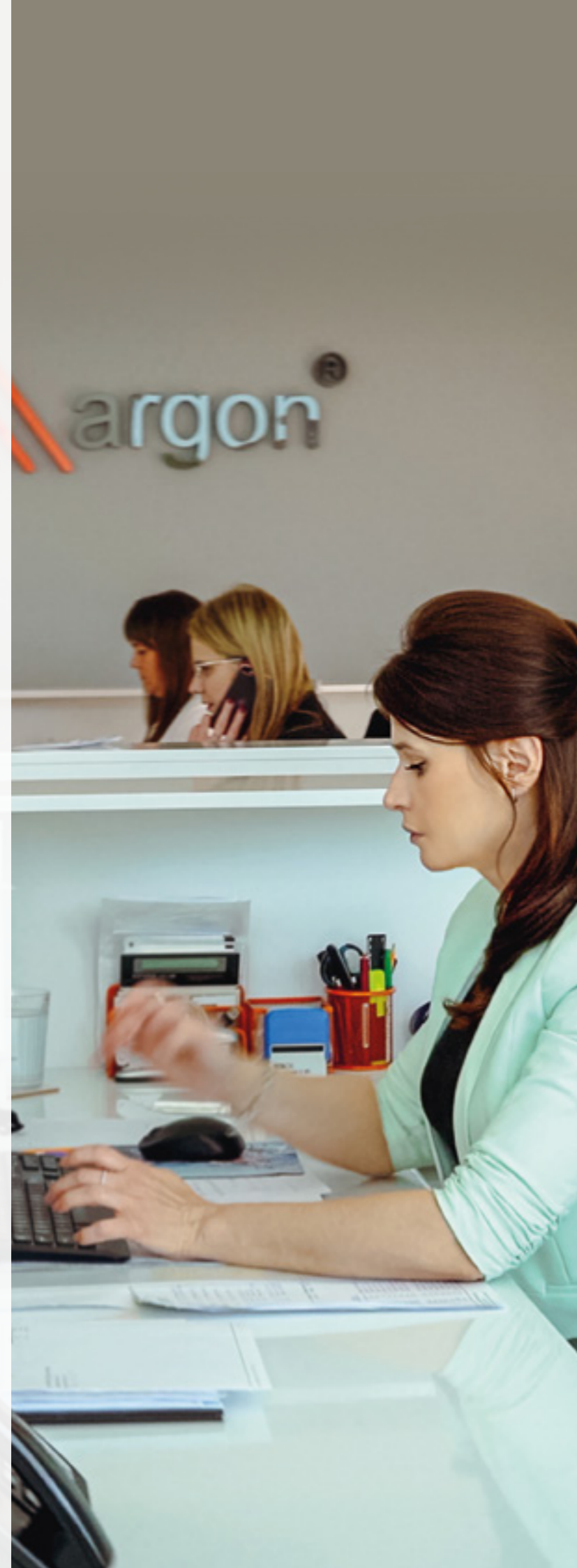

**ÓŚWIETLENIE
DEKORACYJNE**

ABBANO
12

Icons: ⓐ, ⓑ, ⓓ

ABRUZZO
13

Icons: ⓐ, ⓑ, ⓓ

ABSTRACT
16

Icon: ⓐ

BODRUM
37

Icon: ⓐ

BUFFALO
37

Icon: ⓐ

BOLZANO PLUS | BOLZANO
38

Icons: ⓐ, ⓑ

BURGOS
41

Icon: ⓐ

AKRON
16

Icon: ⓐ

ALMADA
17

Icon: ⓑ

ALTEA
18

Icons: ⓐ, ⓑ

AMADORA
20

Icons: ⓐ, ⓑ

CALIGARI
42

Icon: ⓑ

CALVADOS
43

Icon: ⓐ

DECORATO
43

Icon: ⓐ

CALVIA
44

Icon: ⓐ

AMALFI
21

Icon: ⓐ

AMARYLIS
22

Icon: ⓑ

AMAZONKA
22

Icons: ⓑ, ⓐ

ASPEN
23

Icons: ⓐ, ⓑ

CELIA
44

Icons: ⓑ, ⓐ

CLAVA
45

Icons: ⓑ, ⓐ, ⓓ, ⓑ

CAMELOT PLUS | CAMELOT
47

Icons: ⓐ, ⓑ

CAMERON
49

Icon: ⓐ

ASSE
24

Icon: ⓐ

ASTER
25

Icon: ⓑ

ASTI
26

Icons: ⓑ, ⓐ, ⓓ

AUSTIN
27

Icons: ⓑ, ⓐ, ⓓ

CHARLOTTE
50

Icons: ⓐ, ⓑ, ⓓ

CORSO
53

Icons: ⓐ, ⓑ, ⓓ

DORIA
55

Icons: ⓑ, ⓐ, ⓓ, ⓑ

DOVER
57

Icon: ⓐ

AVALONE
28

Icons: ⓐ, ⓑ, ⓓ, ⓑ

AVILA PLUS
31

Icon: ⓐ

BALTIMORE
31

Icon: ⓐ

BEJA
32

Icon: ⓑ

DETROIT
58

Icon: ⓑ

ERBA | ERBA BIS
58

Icons: ⓐ, ⓑ

ETNA PLUS | ETNA
60

Icons: ⓐ, ⓑ

EUFRAT
63

Icons: ⓐ, ⓑ, ⓓ

BELLA
33

Icon: ⓑ

BERKLEY
33

Icon: ⓐ

BEVERLY
34

Icons: ⓐ, ⓑ

BILL
36

Icon: ⓐ

FLAVIO
65

Icon: ⓑ

ROVETTO
65

Icons: ⓑ, ⓐ

FARON
66

Icons: ⓑ, ⓐ, ⓓ

FERRONE
66

Icons: ⓑ, ⓐ



FOTO NEW
67



FOXY
68



FREEMONT
68



FUDŽI
71



LIRANO
95



LINDOS
95



LIVIA
96



LORENA
97



GABIAN
73



GLEN
74



GOMERA PLUS | GOMERA
75



HERMAN
76



LUKKA
98

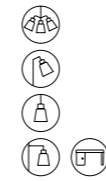

MAGIC
100



MARBELLA PLUS | MARBELLA
102



MINORI
104



HILARY
77



IRUN
79



JAMAJKA
80



JESSE
81



MASSETO
104



MASSIMO PLUS
105



MEGAN
106



MURANO
106



JACKSON
81



KOPERNIK
82



KALIMERA
82



KARIN
84



METIS
107



MITOS
108



MOHITO
108



MORITZ
109



KASER
86



KOS PLUS | KOS
87



KONGO
89



LAGOS
80



NANCY
110



NEWA
110



NASHVILLE
111



OAKLAND
112



LAGUNA
181



LATINA
182



LILLE
184



LINEA
186



OREGON
113



OPTICA
113



ORTE
114



OMBRA
115





SALADO
115



GIN
116



CHICAGO
116



PASADENA
117



TROY
141



TRINI
142



PALLADO
144



VALIANO
145



POLONIA
119



PONTE PLUS | PONTE
120



PORTORYKO
123

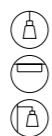

TWIST
124



ZAKYNTOS PLUS | ZAKYNTOS
146



ZAKYNTOS BIS
147



KRYSTAŁY
W MOSIĄDZU

BILBAO
149



RAVELLO
125



PRATO
126



SAGUNTO
127



RENO
128



CADIZ
149



CRUZ
150



DEPORTIVO
151



SALERNO
151



SANDRINO PLUS
128



SANTANA
129



URAL
130



SATELITE PLUS | SATELITE
130



OVIEDO
152



VENETO
153



OŚWIETLENIE
TECHNICZNE

AMORE
155



SEKWANA
133



SERAFINO
133



SICILIA PLUS | SICILIA
134



SINES
136



ARIZONA
156



ATLANTIS
157



CLEVELAND
158



DARLING
159



SKIATOS
276



TENERYFA
277



TOMAR
278



TORRE
279



DARLING LED
162



ESPRESSO
164



GARLAND
265



JASPER
165





OLIMP PLUS | OLIMP
166



ONTARIO LED
167



ONTARIO
168



ROCK
169



ROCKSTAR
169



RODOS PLUS | RODOS
170



RODAN
172



TONI
173



TUBO
175



TYBER PLUS | TYBER
175



VICHY
177



VERMONT
177



OŚWIETLENIE
SZYNOWE

ALTO
179



BANG
179



BERGEN
180



DELTA
180



ELBRUS
181



HORTA
182



MURI
182



NET PLUS | NET
183



ARGON T-RACK SYSTEM
184



-  żyrandole
-  lampy wiszące
-  lampy podłogowe
-  plafony
-  lampy stołowe
-  lampy biurkowe

-  kinkiety
-  listwy
-  zwisy
-  reflektory
-  oprawy stropowe

OŚWIETLENIE DEKORACYJNE



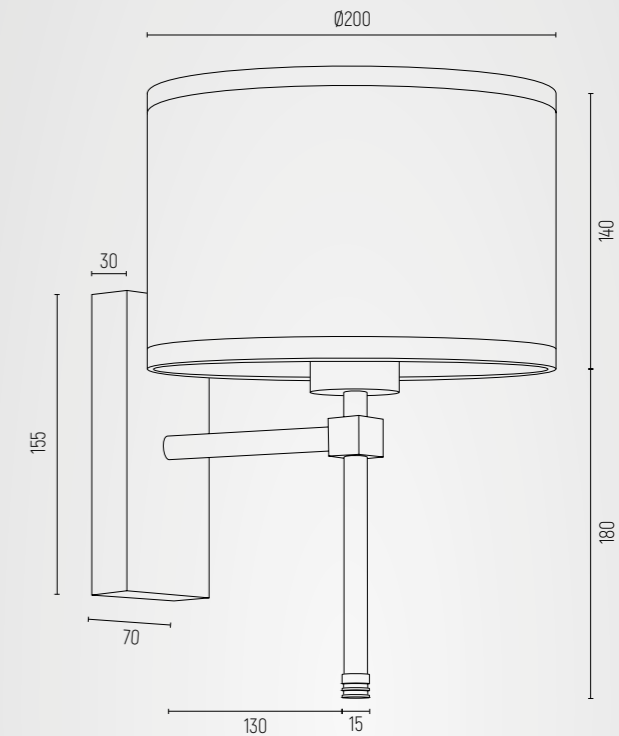

ABBANO

- 2127 - śmietankowy ze złotym paskiem, mosiądz szczotkowany
- 2132 - biały, mosiądz szczotkowany
- 2133 - czarny, mosiądz szczotkowany
- 2146 - zielony, mosiądz szczotkowany
- żyrandol 5 pt.
- 2132, 2133, 2146 - abażur welur, mosiądz
2127 - abażur, mosiądz
- E14 (nie zawiera źródła światła) / 230V | 5 x 7W (max)
- 2127 - 1030 wys. | 700 szer. | 700 gł.
2132, 2133, 2146 - 1030 wys. | 600 szer. | 600 gł.
- 2127 - 3,7
2132, 2133, 2146 - 3,6
- IP 20
- możliwość modyfikacji na włączanie 2+3

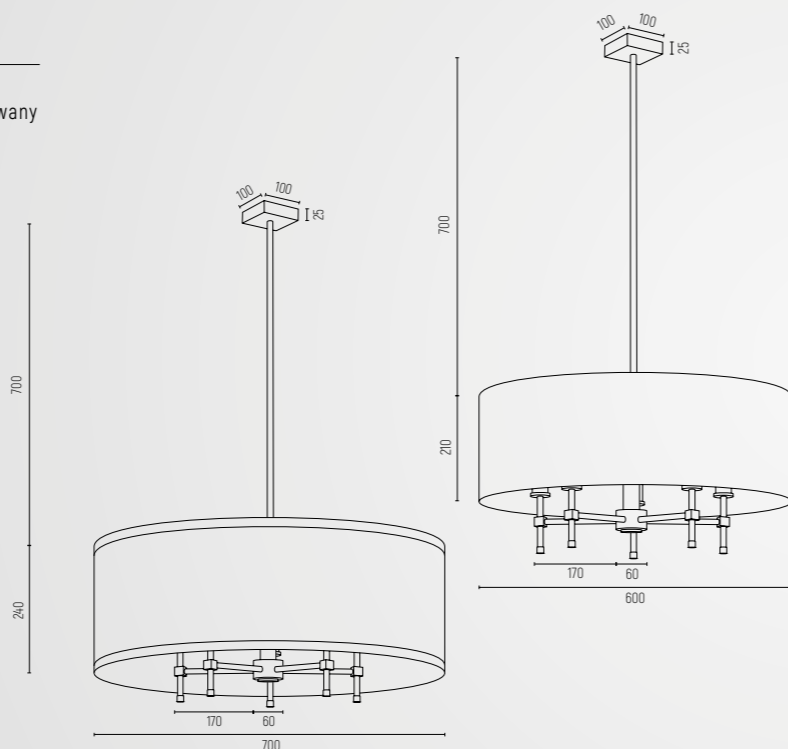

ABBANO

- 8033 - śmietankowy ze złotym paskiem, mosiądz szczotkowany
- 8048 - biały, mosiądz szczotkowany
- 8050 - czarny, mosiądz szczotkowany
- 8107 - zielony, mosiądz szczotkowany
- kinkiet 1 pt.
- 8048, 8050, 8107 - abażur welur, mosiądz
8033 - abażur, mosiądz
- E27 (nie zawiera źródła światła) / 230V | 1 x 15W (max)
- 320 wys. | 200 szer. | 260 gł.
- 0,7
- IP 20
- możliwość zamontowania włącznika na przyścienniku

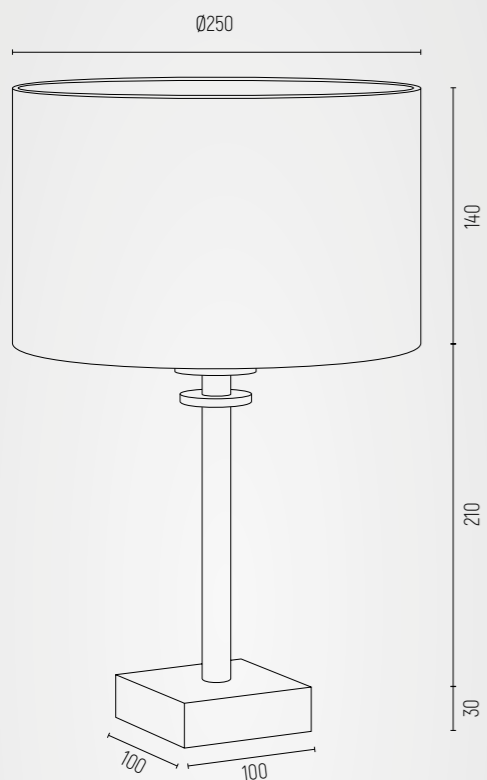

ABBANO

- 8029** - śmietankowy ze złotym paskiem, mosiądz szczotkowany
- 8047** - biały, mosiądz szczotkowany
- 8049** - czarny, mosiądz szczotkowany
- 8106** - zielony, mosiądz szczotkowany
- lampa stołowa 1 pt.
- 8047, 8049, 8106** - abażur welur, mosiądz
8029 - abażur, mosiądz
- E27 (nie zawiera źródła światła) / 230V | 1 x 15W (max)
- 380 wys. | 250 szer. | 250 gł.
- 0,9
- IP 20



ABRUZZO

- 8030, 8034** - biały, mosiądz szczotkowany
- 8031, 8035** - czarny, mosiądz szczotkowany
- 8108, 8109** - zielony, mosiądz szczotkowany
- abażur welur, mosiądz
- E14 (nie zawiera źródła światła) / 230V | 1 x 7W (max)
- IP 20

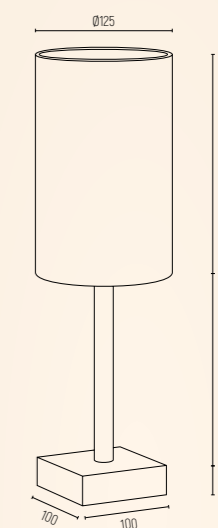

- 8030, 8031, 8108** - lampa stołowa 1 pt.
- 370 wys. | 125 szer. | 125 gł.
- 0,7

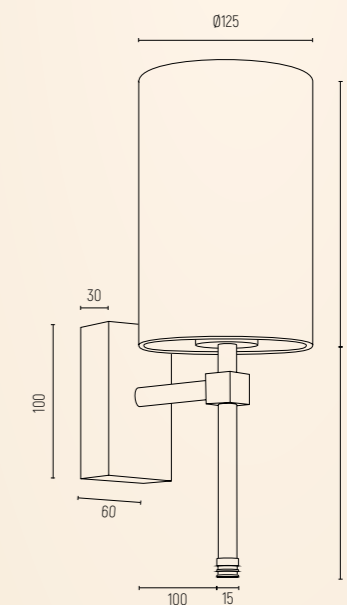

- 8034, 8035, 8109** - kinkiet 1 pt.
- 340 wys. | 125 szer. | 175 gł.
- 0,5
- możliwość zamontowania włącznika na przyścienniku



ABRUZZO

-  2134 - biały, msiądz szczotkowany
-  2135 - czarny, msiądz szczotkowany
-  2147 - zielony, msiądz szczotkowany
-  żyrandol 5 pt.
-  abażur welur, msiądz
-  E14 (nie zawiera źródła światła) / 230V | 5 x 7W (max)
-  780 wys. | 700 szer. | 700 gł.
-  3,5
-  IP 20
-  możliwość modyfikacji na włączanie 2+3

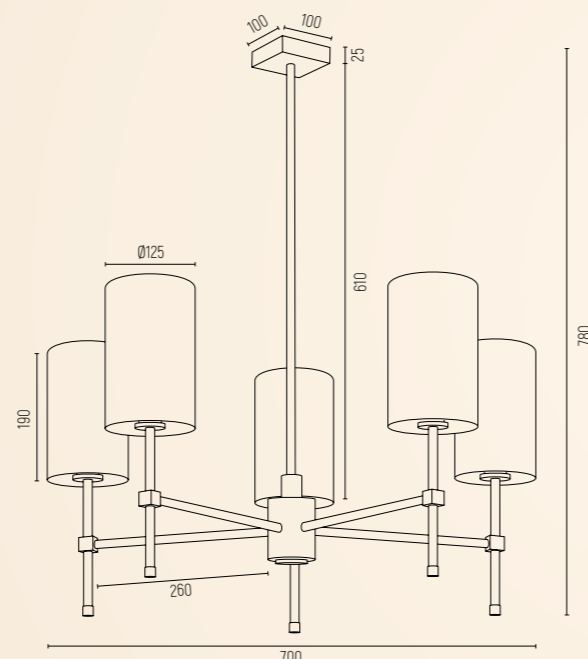

ABRUZZO

-  5051 - biały, msiądz szczotkowany
-  5052 - czarny, msiądz szczotkowany
-  5055 - zielony, msiądz szczotkowany
-  żyrandol 8 pt.
-  abażur welur, msiądz
-  E14 (nie zawiera źródła światła) / 230V | 8 x 7W (max)
-  910 wys. | 860 szer. | 860 gł.
-  5
-  IP 20
-  możliwość modyfikacji na włączanie 4+4 lub 3+5

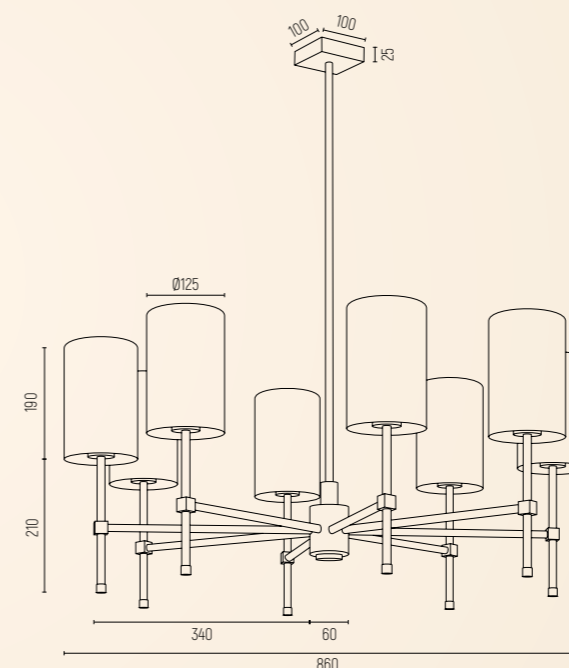















ABSTRACT 1695

ABSTRACT 1696

ABSTRACT

-  1695 - opal mat, msiądz
-  1696 - opal mat, czarny struktura, el. msiądzowane
-  lampa wisząca 4 pt.
-  1695 - szkło, stal msiądzowana
-  1696 - szkło, stal lakierowana, stal msiądzowana
-  E14 (nie zawiera źródła światła) / 230V | 4 x 7W (max)
-  max. 950 wys. | 860 szer. | 140 gł.
-  3,5
-  IP 20
-  możliwość regulacji ramion + możliwość zastosowania stali chromowanej / stali lakierowanej lub el. chromowanych albo lakierowanych zamiast msiądz / el. msiądzowane

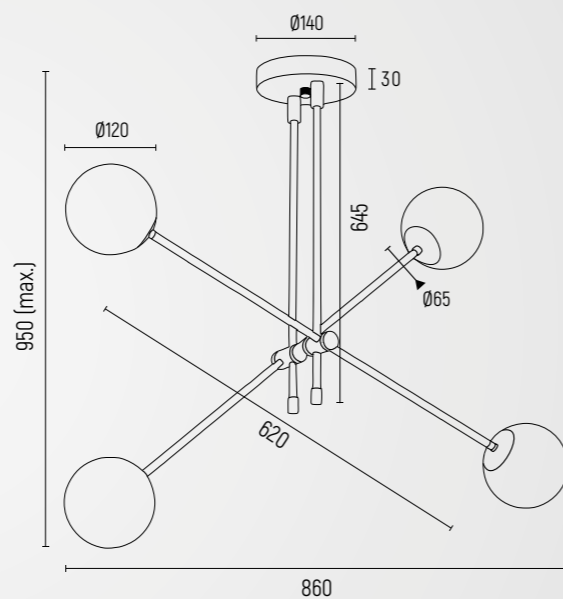

AKRON 1036



AKRON 1037



AKRON 1038



AKRON 1039

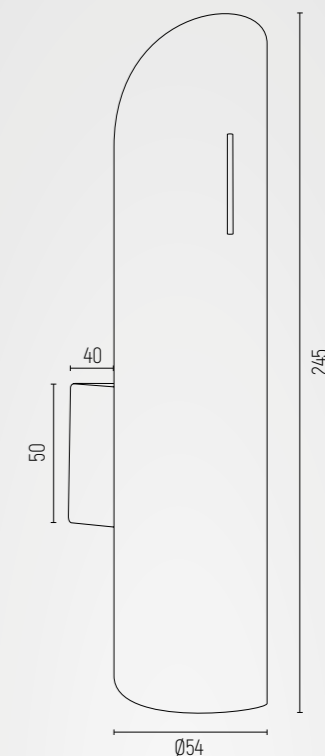

AKRON

-  kinkiet 2 pt.
-  G9 (nie zawiera źródła światła) / 230V | 2 x 6W (max)
-  245 wys. | 55 szer. | 80 gł.
-  0,55
-  IP 20
-  świeci góra-dół
-  1036 - biały struktura
-  1037 - czarny struktura
-  stal lakierowana
-  1038 - chrom
-  stal chromowana
-  1039 - msiądz
-  stal msiądzowana



ALMADA 4231



ALMADA 4233











ALMADA 4232









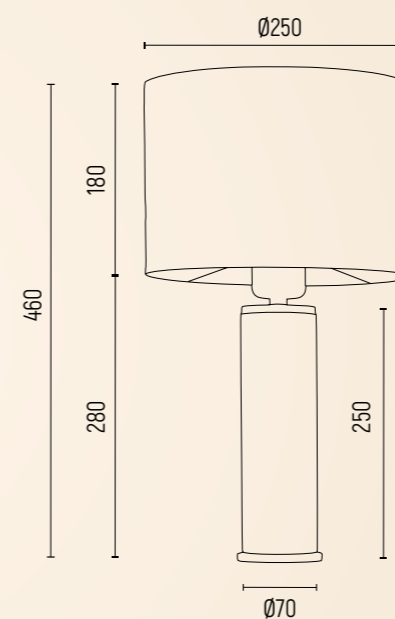
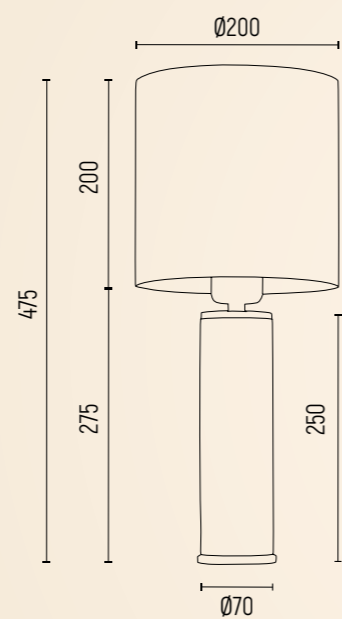

ALMADA 4234

ALMADA

-  4231 - biały, biały struktura, el. miedziane
-  4233 - biały, czarna struktura, el. miedziane
-  lampa stołowa 1 pt.
-  abażur, stal lakierowana, stal miedziana
-  E27 (nie zawiera źródła światła) / 230V | 1 x 15W (max)
-  475 wys. | 200 szer. | 200 g.
-  IP 20
-  1,5



ALMADA

-  4232 - czarny ze złotym dekokiem, biały struktura, el. miedziane
-  4234 - czarny ze złotym dekokiem, czarna struktura, el. miedziane
-  lampa stołowa 1 pt.
-  abażur, stal lakierowana, stal miedziana
-  E27 (nie zawiera źródła światła) / 230V | 1 x 15W (max)
-  460 wys. | 250 szer. | 250 g.
-  IP 20
-  1,5

ALTEA 4071



ALTEA 4072

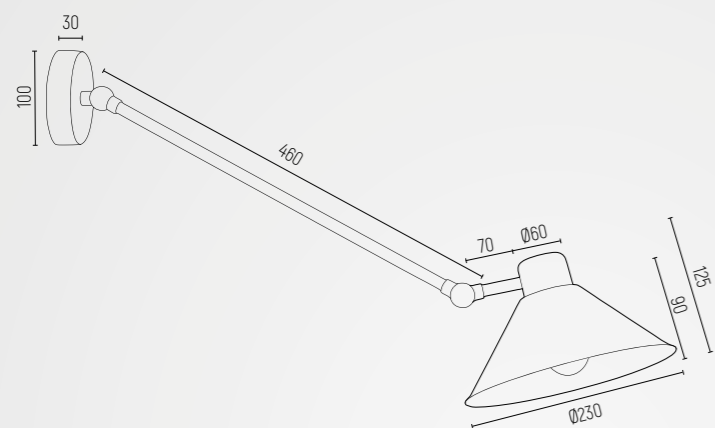

ALTEA

- 4071 - biały struktura
- 4072 - czarny struktura
- 🔧 kinkiet 1 pt.
- 🏠 stal lakierowana
- 💡 E27 (nie zawiera źródła światła) / 230V | 1 x 15W (max)
- 📏 700 wys. | 225 szer. | 700 gł.
- ⚖️ 0,75
- 🛡️ IP 20
- ⊕ dowolna regulacja/możliwość zamontowania włącznika na przycienniku



ALTEA 4073



ALTEA 4074

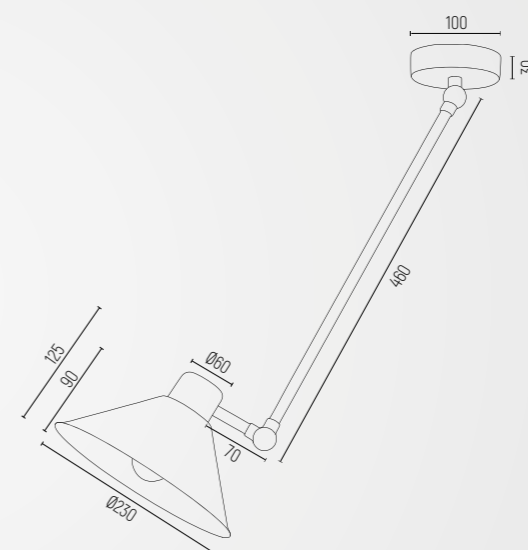

ALTEA

- 4073 - biały struktura
- 4074 - czarny struktura
- 🔧 lampa wisząca 1 pt.
- 🏠 stal lakierowana
- 💡 E27 (nie zawiera źródła światła) / 230V | 1 x 15W (max)
- 📏 700 wys. | 700 szer. | 225 gł.
- ⚖️ 0,75
- 🛡️ IP 20
- ⊕ dowolna regulacja



ALTEA 861



ALTEA 1451











ALTEA 862



ALTEA 1452

ALTEA

-  861 - biały struktura
-  862 - czarny struktura
-  lampa wisząca 2 pt.
-  stal lakierowana
-  E27 (nie zawiera źródła światła) / 230V | 2 x 15W (max)
-  700 wys. | 1330 szer. | 225 g.
-  1,3
-  IP 20
-  dowolna regulacja

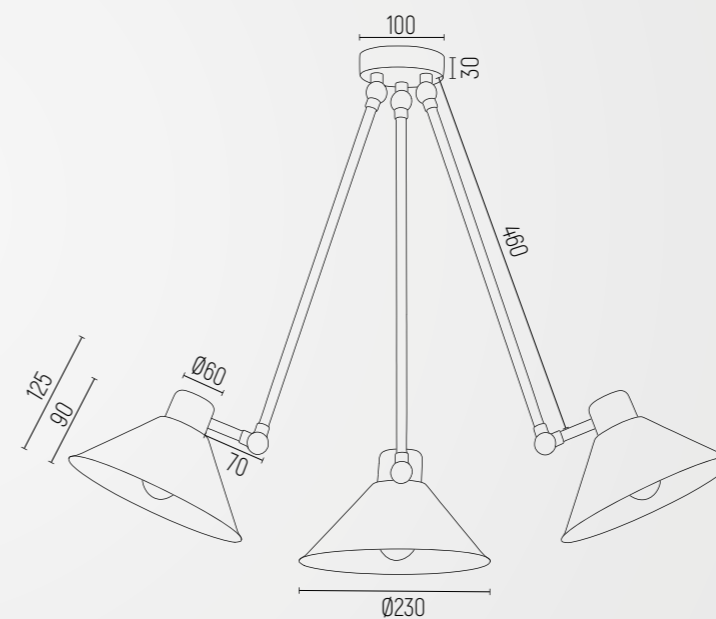
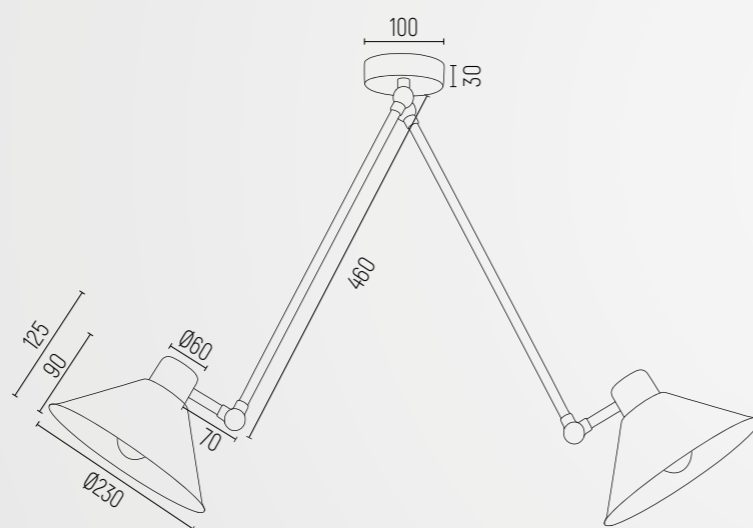





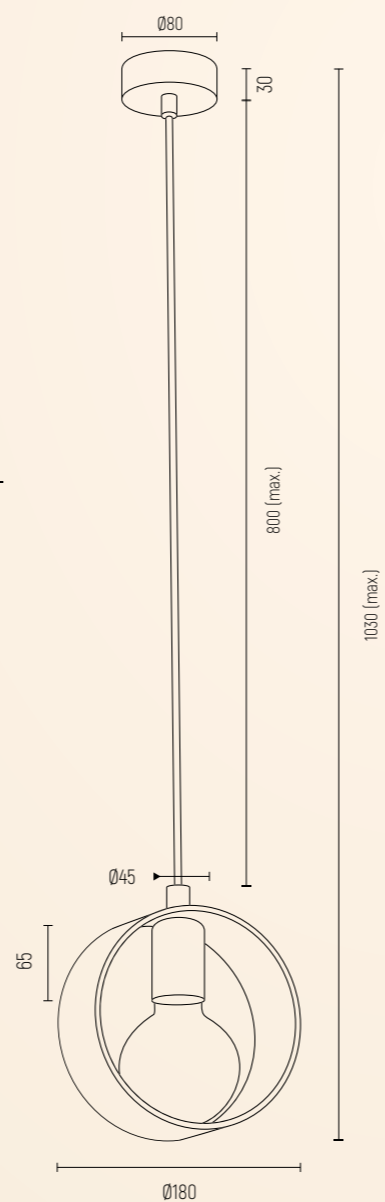
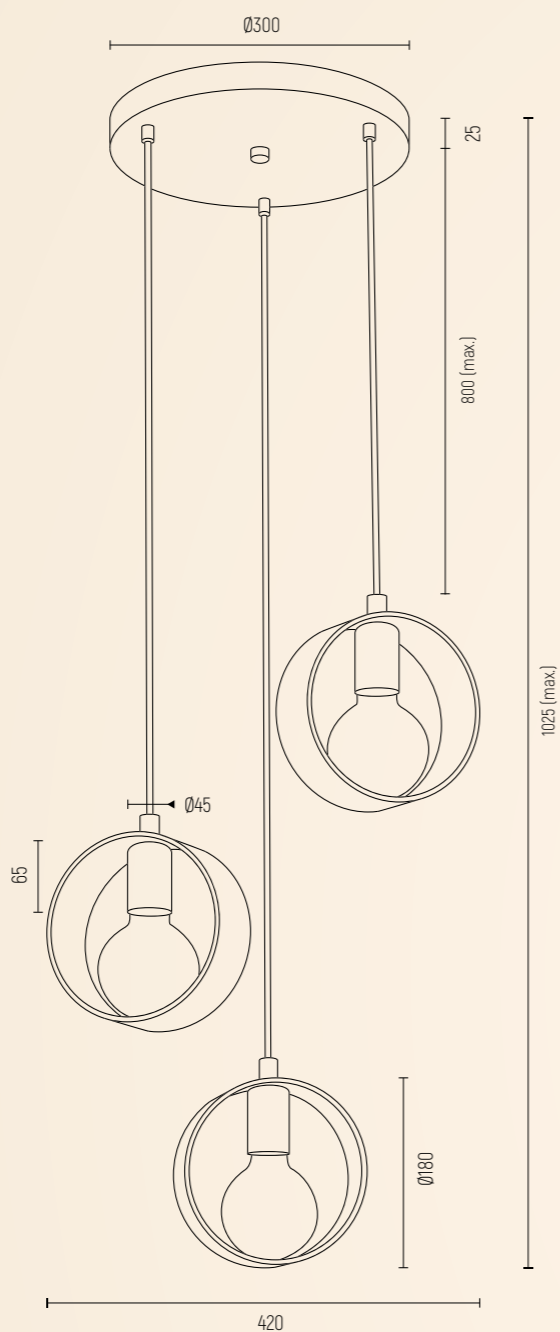
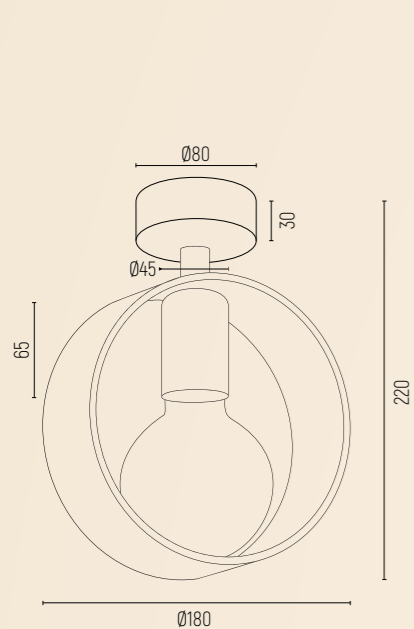

ALTEA





-  1451 - biały struktura
-  1452 - czarny struktura
-  lampa wisząca 3 pt.
-  stal lakierowana
-  E27 (nie zawiera źródła światła) / 230V | 3 x 15W (max)
-  700 wys. | 1330 szer. | 1330 g.
-  2
-  IP 20
-  dowolna regulacja







AMADORA

-  czarny struktura, el. mosiądzowane
-  stal lakierowana, stal mosiądzowana
-  IP 20

-  **4069** - plafon 1 pt.
-  E27 (nie zawiera źródła światła) / 230V | 1 x 15W (max)
-  220 wys. | 180 szer. | 65 gt.
-  0,8

-  **4067** - lampa wisząca 1 pt.
-  E27 (nie zawiera źródła światła) / 230V | 1 x 15W (max)
-  1030 (przewód 800) wys. | 180 szer. | 65 gt.
-  0,9

-  **1449** - lampa wisząca 3 pt.
-  E27 (nie zawiera źródła światła) / 230V | 3 x 15W (max)
-  1025 (najdłuższy przewód 800) wys. | 420 szer. | 420 gt.
-  2,4

-  możliwość modyfikacji na włączanie 1+2
+ możliwość zastosowanie el. chromowanych
lub lakierowanych zamiast el. mosiądzowanych



AMADORA 4069





AMADORA 1449









AMADORA 4067

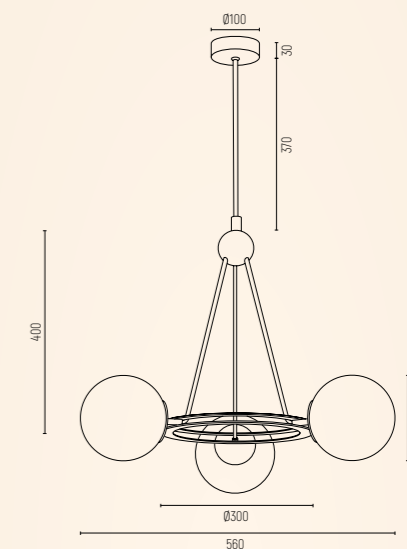





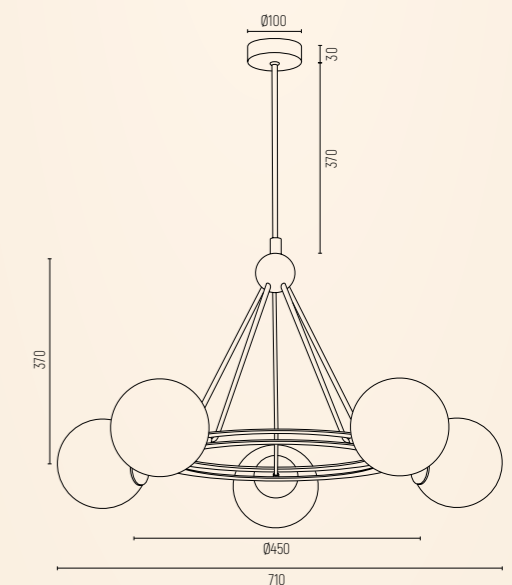

AMALFI

-  opal mat, czarna struktura, mosiądz
-  szkło, stal lakierowana, stal mosiądzowana
-  IP 20



-  6150 - żyrandol 3 pt.
-  E27 (nie zawiera źródła światła) / 230V | 3 x 15W (max)
-  880 wys. | 560 szer. | 560 gt.
-  3,7
-  możliwość modyfikacji na włączanie 1+2



-  2119 - żyrandol 5 pt.
-  E27 (nie zawiera źródła światła) / 230V | 5 x 15W (max)
-  850 wys. | 710 szer. | 710 gt.
-  4,5
-  możliwość modyfikacji na włączanie 2+3



AMARYLIS 4095



AMAZONKA 3030



AMAZONKA 3031









AMAZONKA 3033



AMAZONKA 3035

AMARYLIS

-  4095 - opal mat
-  lampa stołowa 1 pt.
-  szkło
-  E27 (nie zawiera źródła światła) / 230V | 1 x 15W (max)
-  340 wys. | 270 szer. | 270 gł.
-  2,5
-  IP 20

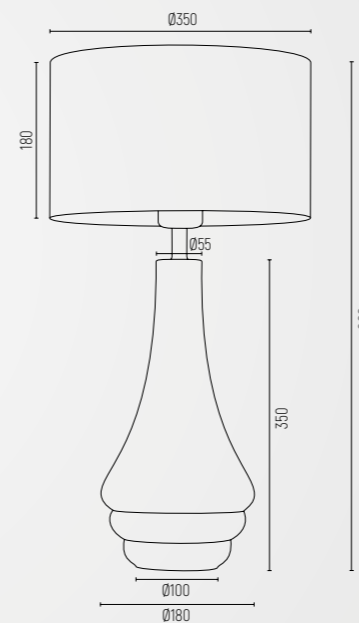
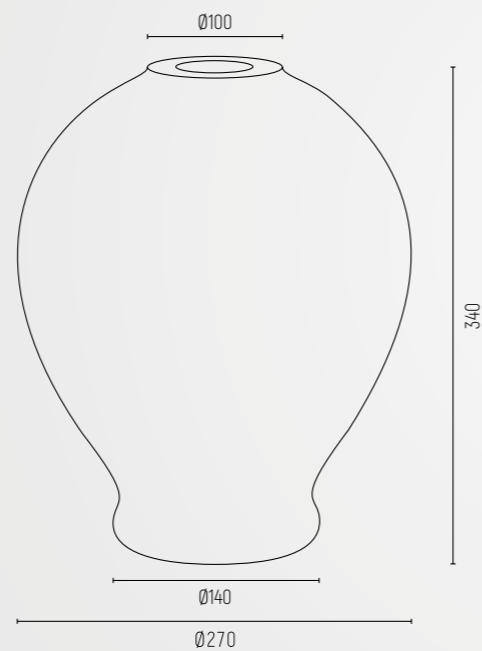

AMAZONKA

-  3030 - ciemno szara podstawa
-  3031 - transparentna podstawa
-  3033 - czarna podstawa
-  3035 - dymna podstawa
-  lampa stołowa 1 pt.
-  szkło, abażur
-  E27 (nie zawiera źródła światła) / 230V | 1 x 15W (max)
-  600 wys. | 350 szer. | 350 gł.
-  1,6
-  IP 20

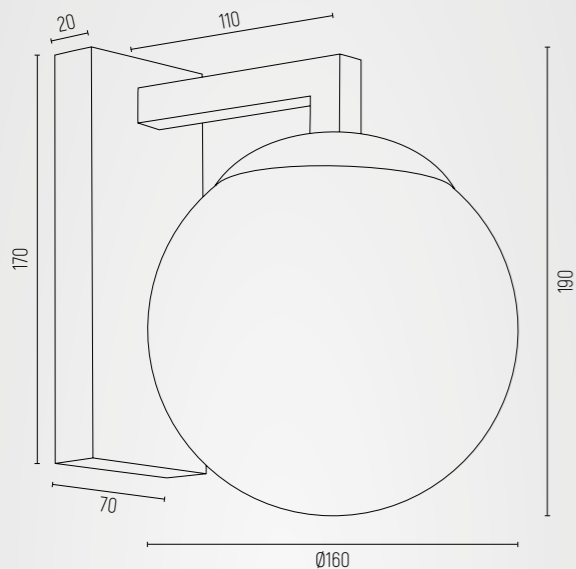

ASPEN 3733



ASPEN 3734



ASPEN 3735



ASPEN 1644



ASPEN 1646



ASPEN 1645

ASPEN





-  3733 - opal mat, biały struktura
-  3734 - opal mat, grafit struktura
-  3735 - opal mat, chrom
-  kinkiet 1 pt.
-  3733, 3734 - szkło, stal lakierowana
3735 - szkło, stal chromowana
-  E27 (nie zawiera źródła światła) / 230V | 1 x 15W (max)
-  190 wys. | 160 szer. | 200 gł.
-  0,9
-  IP 20
-  możliwość zamontowania włącznika na przyścienniku

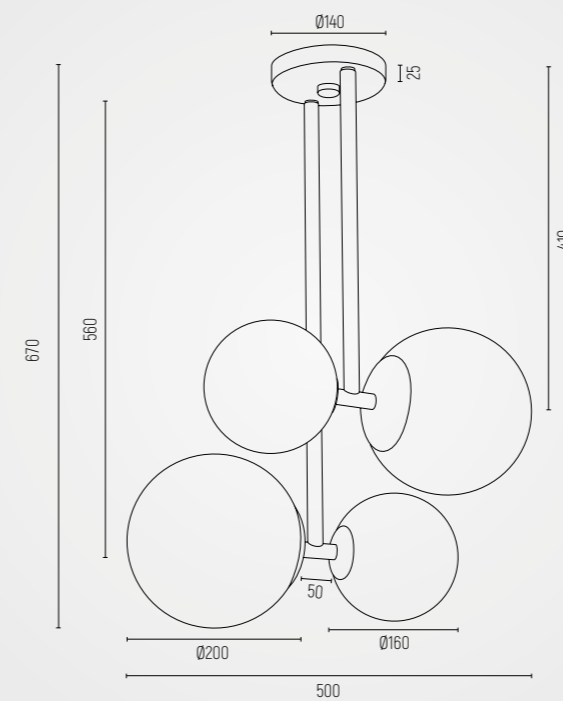



ASPEN

-  1644 - opal mat, biały struktura
-  1645 - opal mat, grafit struktura
-  1646 - opal mat, chrom
-  lampa wisząca 4 pt.
-  1644, 1645 - szkło, stal lakierowana
1646 - szkło, stal chromowana
-  E27 (nie zawiera źródła światła) / 230V | 4 x 15W (max)
-  670 wys. | 500 szer. | 500 gł.
-  4,1
-  IP 20
-  możliwość modyfikacji na włączanie 2+2



ASSE



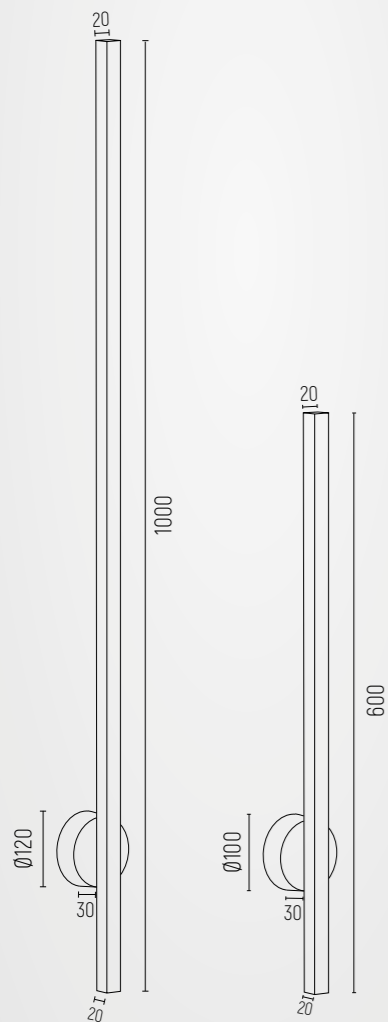

-  czarny struktura
-  stal lakierowana
-  IP 20
-  możliwość zastosowania modułu LED o temperaturze barwowej 4000K - nieodpłatnie





-  **8051** - listwa LED dłuższa
-  LED (zintegrowany) / 230V / 3000K | 1 x 10W
-  1000 wys. | 120 szer. | 50 g.
-  0,4







-  **8052** - listwa LED krótsza
-  LED (zintegrowany) / 230V / 3000K | 1 x 6W
-  600 wys. | 100 szer. | 50 g.
-  0,3

ASSE

-  **8053, 8063** - msiądz szczotkowany
-  **8054** - czarny struktura
-  **8055** - biały struktura
-  IP 20
-  możliwość zastosowania modułu LED o temperaturze barwowej 4000K - nieodpłatnie

-  **8053** - listwa LED
-  msiądz
-  LED (zintegrowany) / 230V / 3000K | 1 x 10W
-  1000 wys. | 105 szer. | 60 g.
-  1

-  **8063** - listwa LED
-  msiądz
-  LED (zintegrowany) / 230V / 3000K | 1 x 6W
-  600 wys. | 85 szer. | 60 g.
-  0,6

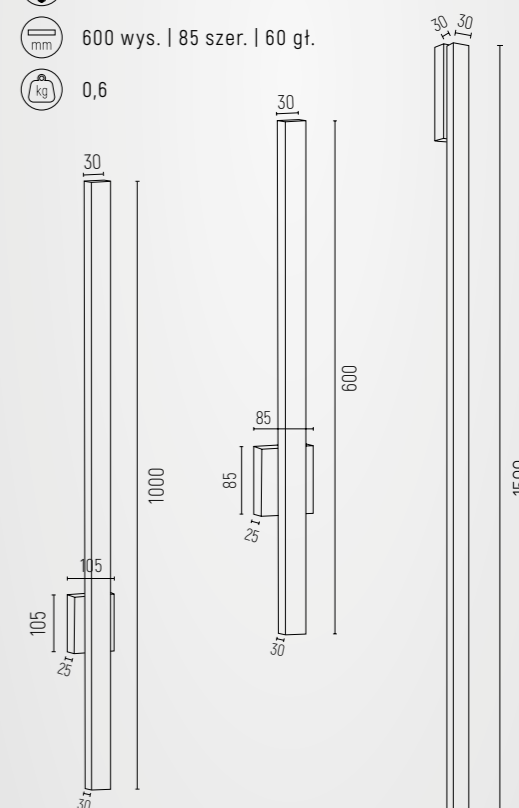

-  **8054, 8055** - listwa LED
-  stal lakierowana
-  LED (zintegrowany) / 230V / 3000K | 1 x 15W
-  1500 wys. | 50 szer. | 55 g.
-  1,4

ASSE 8051

ASSE 8052

ASSE 8053

ASSE 8063

ASSE 8054

ASSE 8055



ASTER 3357









ASTER 3420



ASTER 3421

ASTER

-  3357 - czarny, czarny
-  3420 - czarny, biały
-  3421 - czarny, drewno naturalne
-  lampa podłogowa 1 pt.
-  abażur, drewno
-  E27 (nie zawiera źródła światła) / 230V | 1 x 15W (max)
-  1500 wys. | 600 szer. | 600 gł.
-  3,4
-  IP 20

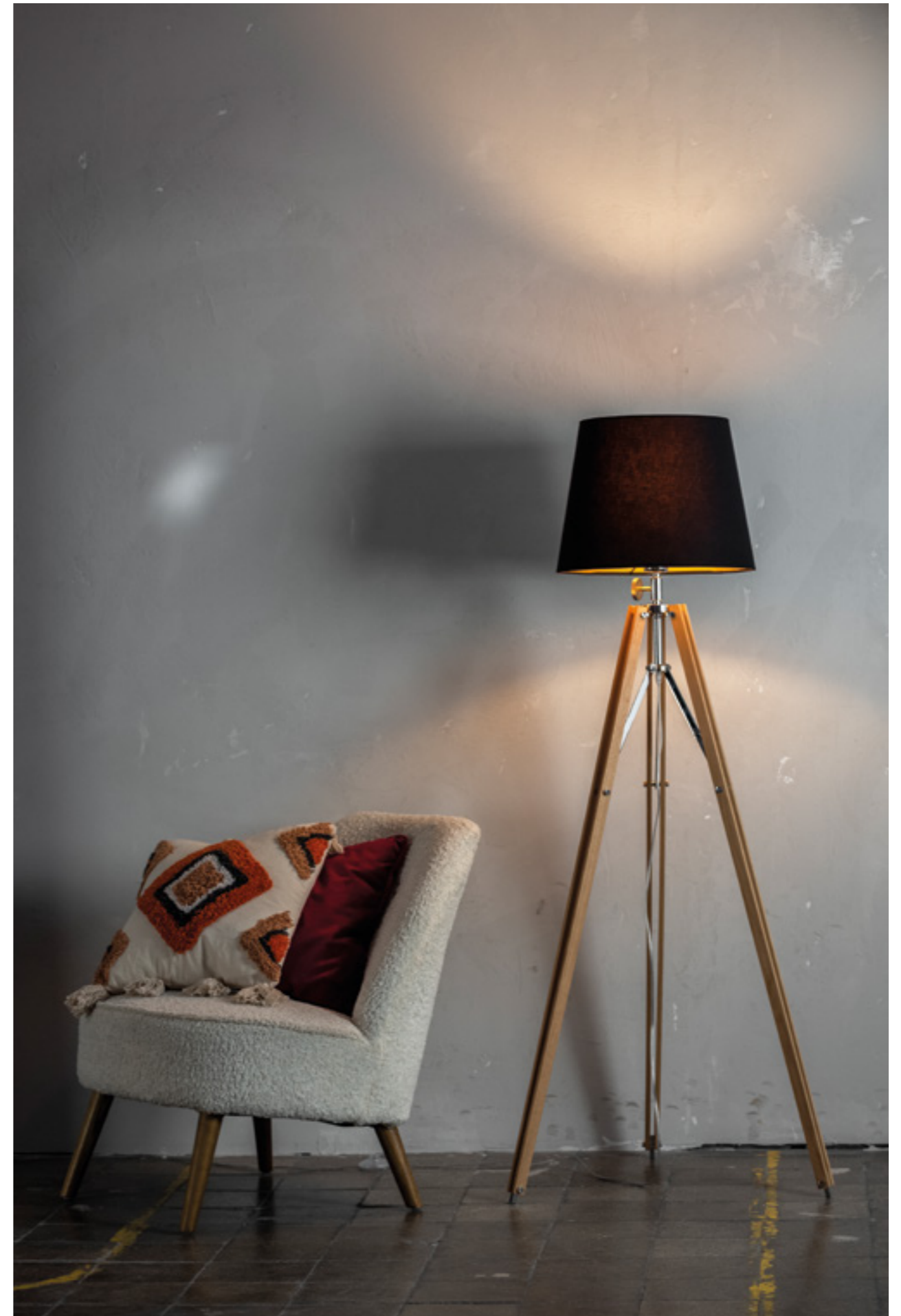
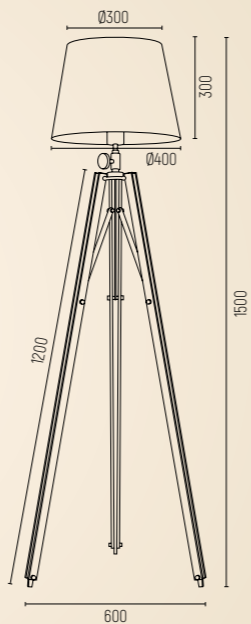



ASTI 3846



ASTI 3851



ASTI 3848



ASTI 3847



ASTI 3850



ASTI 3849

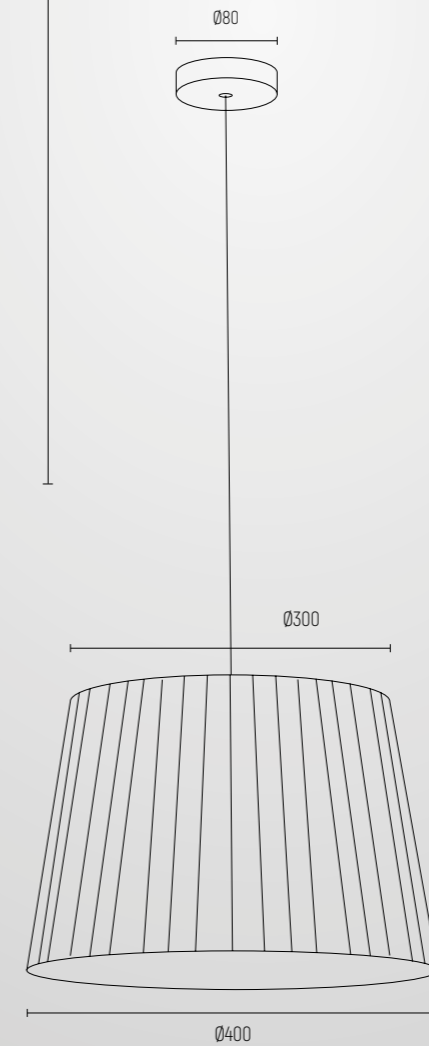
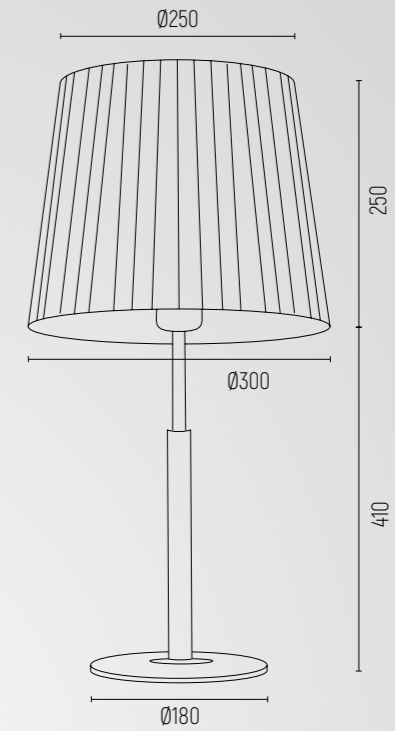



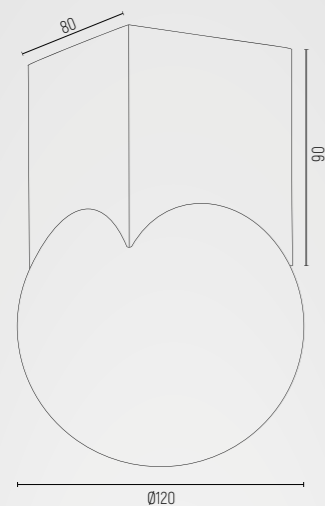

ASTI

-  **3846, 3848, 3850** - czerwony, chrom
-  **3847, 3849, 3851** - biały, chrom
-  abażur, stal chromowana
-  E27 (nie zawiera źródła światła) / 230V | 1 x 15W (max)
-  IP 20
-  możliwość zastosowania stali mosiądzowanej lub lakierowanej zamiast stali chromowanej
-  **3846, 3847** - lampa stołowa 1 pt.
-  660 wys. | 300 szer. | 300 gł.
-  3,3
-  **3848, 3849** - lampa podłogowa 1 pt
-  1750 wys. | 450 szer. | 450 gł.
-  6,4
-  **3850, 3851** - lampa wisząca 1 pt.
-  1120 wys. | 400 szer. | 400 gł.
-  1,2



AUSTIN

-  4712, 4720 - opal mat, mosiądz szczotkowany
-  4713, 4721 - opal mat, czarny mat
-  E14 (nie zawiera źródła światła) / 230V | 1 x 7W (max)
-  180 wys. | 120 szer. | 120 gł.
-  IP 20

-  plafon 1 pł.
-  4712 - szkło, mosiądz
4713 - szkło, stal lakierowana
-  0,7
-  lampa stołowa 1 pł.
-  4720 - szkło, mosiądz
4721 - szkło, stal lakierowana
-  0,6
-  włącznik na czarnym przewodzie

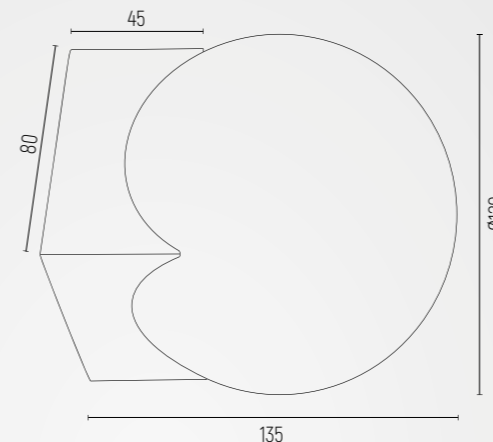
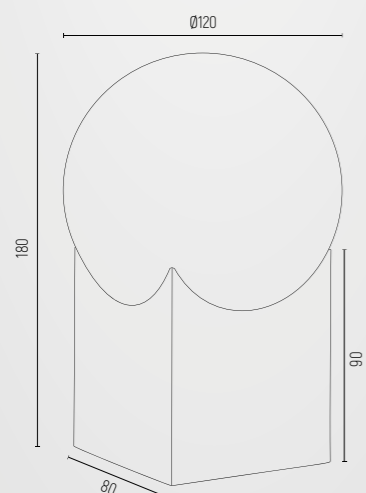







AUSTIN



-  4714 - opal mat, mosiądz szczotkowany
-  4715 - opal mat, czarny mat
-  kinkiet 1 pł.
-  4714 - szkło, mosiądz
4715 - szkło, stal lakierowana
-  E14 (nie zawiera źródła światła) / 230V | 1 x 7W (max)
-  120 wys. | 120 szer. | 135 gł.
-  0,5
-  IP 20





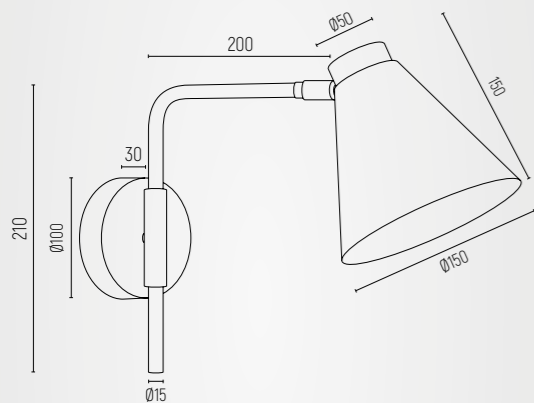

AVALONE

-  **8006, 8007** - biały struktura, el. mosiądzowane
-  **8008, 8009** - czarny struktura, el. mosiądzowane
-  stal lakierowana, stal mosiądzowana
-  E27 (nie zawiera źródła światła) / 230V | 1 x 15W (max)
-  IP 20
-  możliwość regulacji, możliwość zamontowania włącznika na przycienniku | możliwość zastosowania el. chromowanych lub lakierowanych zamiast el. mosiądzowanych

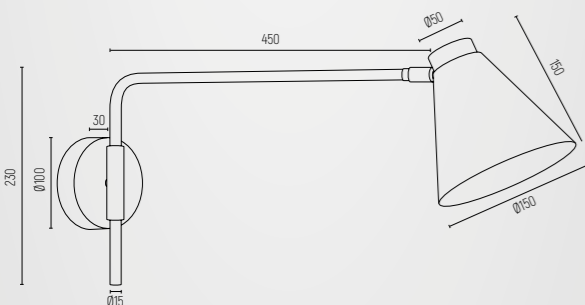

-  **8006, 8008** - kinkiet 1 pt.
-  220 wys. | 150 szer. | 340 gt.
-  0,8



-  **8007, 8009** - kinkiet 1 pt. na dłuższym wysięgniku
-  240 wys. | 150 szer. | 570 gt.
-  0,9



AVALONE 8006



AVALONE 8008



AVALONE 8007



AVALONE 8009

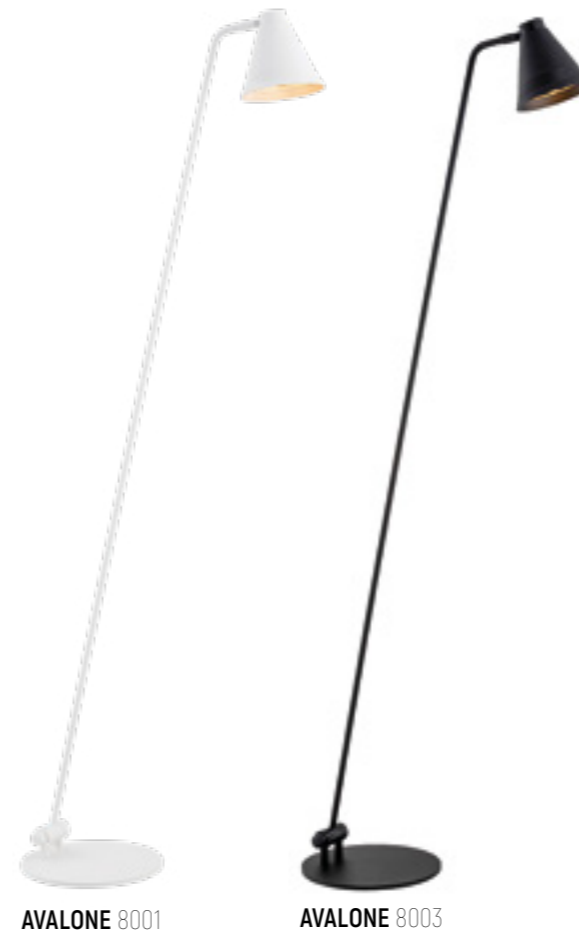

AVALONE 8001

AVALONE 8003







AVALONE 7076

AVALONE 7077

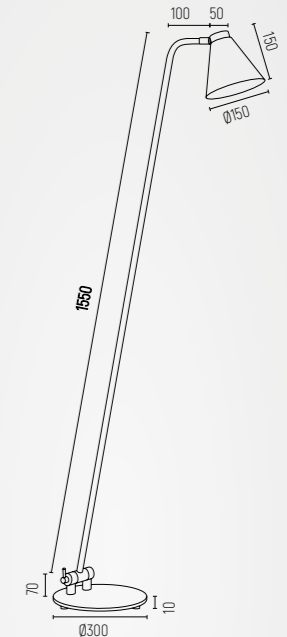

AVALONE

-  **8001, 7076** - biały struktura
-  **8003, 7077** - czarny struktura
-  stal lakierowana
-  1680 wys. | 300 szer. | 300 gt.
-  IP 20
-  możliwość regulacji

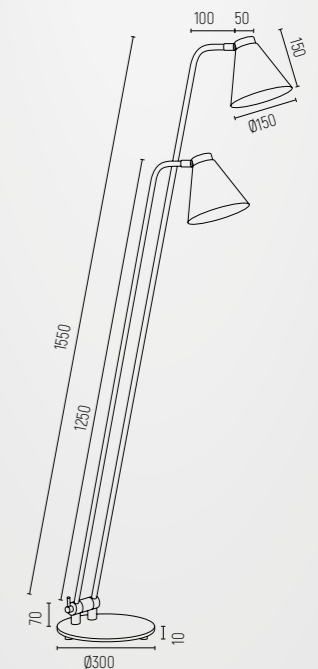

-  **8001, 8003** - lampa podłogowa 1 pt.
-  E27 (nie zawiera źródła światła) / 230V | 1 x 15W (max)
-  5,3



-  **7076, 7077** - lampa podłogowa 2 pt.
-  E27 (nie zawiera źródła światła) / 230V | 2 x 15W (max)
-  6,5



AVALONE 1773



AVALONE 1774











AVALONE 2551





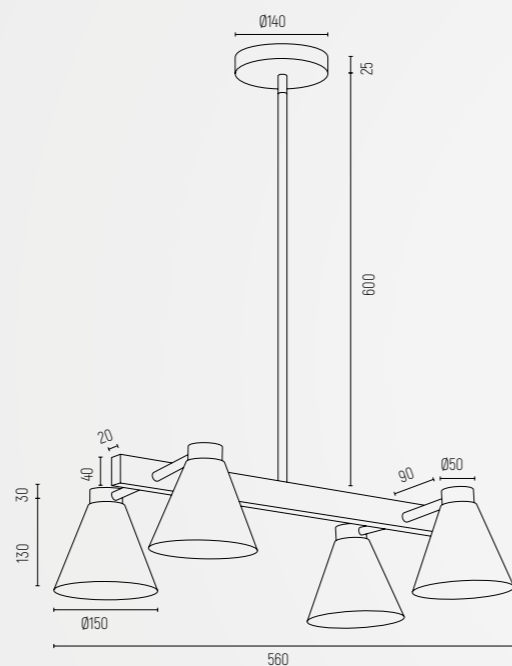

AVALONE 2552

AVALONE

-  1773 - biały struktura, el. mosiądzowane
-  1774 - czarny struktura, el. mosiądzowane
-  żyrandol 4 pt.
-  stal lakierowana, stal mosiądzowana
-  E27 (nie zawiera źródła światła) / 230V | 4 x 15W (max)
-  790 wys. | 560 szer. | 400 g.
-  3
-  IP 20
-  możliwość regulacji, możliwość modyfikacji na włączanie 2+2 | możliwość zastosowania el. chromowanych lub lakierowanych zamiast el. mosiądzowanych



AVALONE

-  2551 - biały struktura, el. mosiądzowane
-  2552 - czarny struktura, el. mosiądzowane
-  żyrandol 6 pt.
-  stal lakierowana, stal mosiądzowana
-  E27 (nie zawiera źródła światła) / 230V | 6 x 15W (max)
-  790 wys. | 850 szer. | 400 g.
-  4,5
-  IP 20
-  możliwość regulacji, możliwość modyfikacji na włączanie 2+4 lub 3+3 | możliwość zastosowania el. chromowanych lub lakierowanych zamiast el. mosiądzowanych

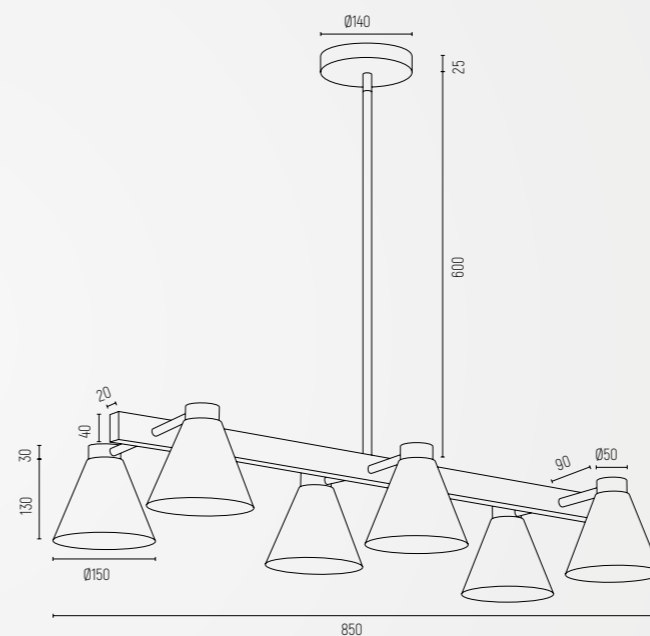



AVALONE 8000



AVALONE 8002



AVALONE

- 8000 - biały struktura
- 8002 - czarny struktura
- 🔧 lampa biurkowa 1 pł.
- 🏠 stal lakierowana,
- 💡 E27 (nie zawiera źródła światła) / 230V | 1 x 15W (max)
- 📏 550 wys. | 180 szer. | 300 gł.
- ⚖️ 2,6
- 🛡️ IP 20
- ⊕ możliwość regulacji

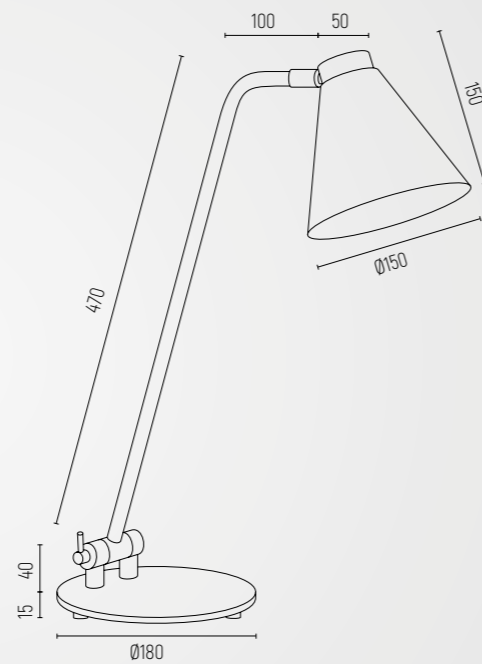

AVILA PLUS

- opal mat, czarna struktura, msiądz
- szkło, stal lakierowana, stal msiądzowana
- IP 20

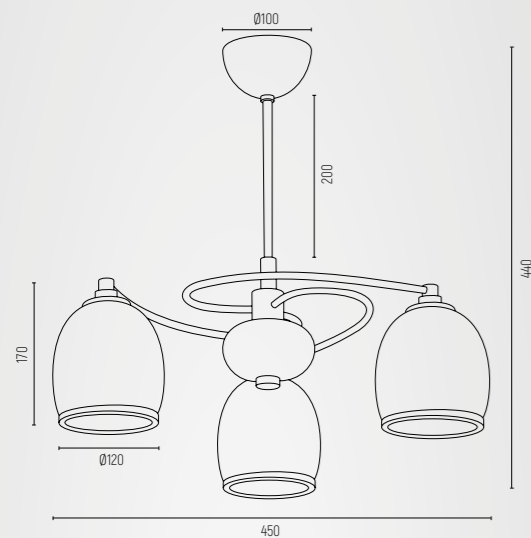

- 6144 - żyrandol 3 pt.
- E27 (nie zawiera źródła światła) / 230V | 3 x 15W (max)
- 440 wys. | 450 szer. | 450 g.
- 1,8
- możliwość modyfikacji na włącznicie 1+2

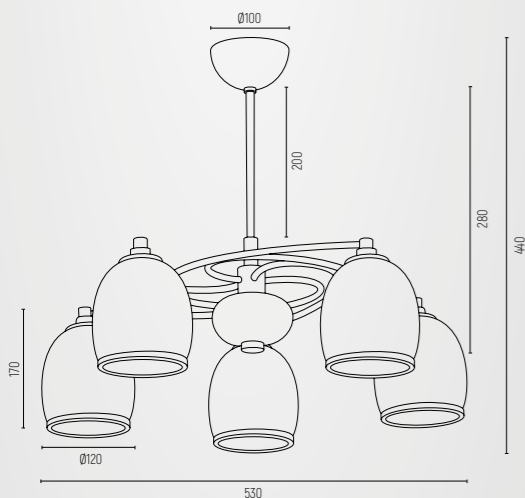

- 2115 - żyrandole 5 pt.
- E27 (nie zawiera źródła światła) / 230V | 5 x 15W (max)
- 440 wys. | 530 szer. | 530 g.
- 2,6
- możliwość modyfikacji na włącznicie 2+3



AVILA PLUS 6144



AVILA PLUS 2115



BALTIMORE 4675



BALTIMORE 4676

BALTIMORE

- lampa wisząca 1 pt.
- E27 (nie zawiera źródła światła) / 230V | 1 x 15W (max)
- IP 20

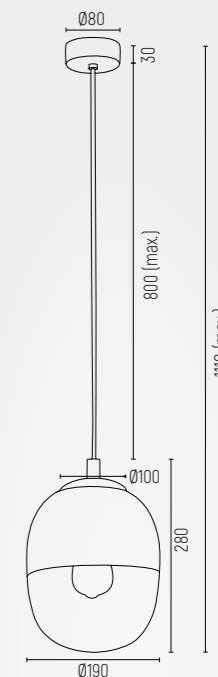





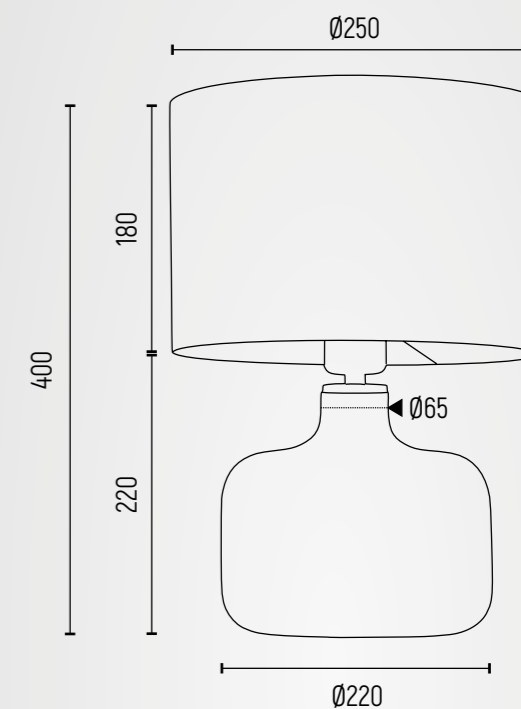
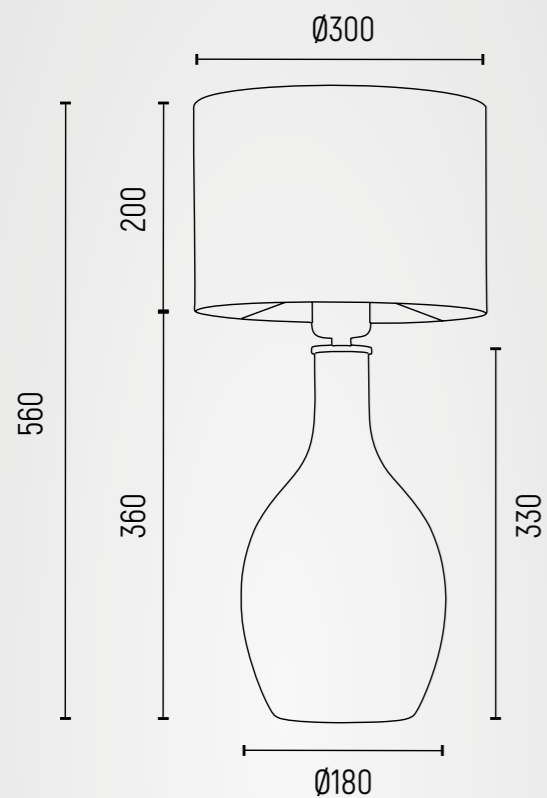

- 4675 - opal mat, transparent, el. msiądzowane
- szkło, stal msiądzowana
- przewód max. 800, całość 1110 wys. | 190 szer. | 190 g.
- 1,1



- 4676 - opal mat, transparent, el. chromowane
- szkło, stal chromowana
- przewód max. 800, całość 1060 wys. | 190 szer. | 190 g.
- 0,9



BEJA

-  **4235** - czarny ze złotym dekorem, czarny połysk, el. mosiądzowane
-  **4359** - biało-szary ze złotym dekorem, biały połysk, el. mosiądzowane
-  **4360** - biało-szary ze złotym dekorem, szary połysk, el. mosiądzowane
-  lampa stołowa 1 pt.
-  abażur, szkło, stal mosiądzowana
-  E27 (nie zawiera źródła światła) / 230V | 1 x 15W (max)
-  560 wys. | 300 szer. | 300 g.
-  1,4
-  IP 20

BEJA

-  **4236** - czarny ze złotym dekorem, czarny połysk, el. mosiądzowane
-  **4361** - biało-szary ze złotym dekorem, biały połysk, el. mosiądzowane
-  **4362** - biało-szary ze złotym dekorem, szary połysk, el. mosiądzowane
-  lampa stołowa 1 pt.
-  abażur, szkło, stal mosiądzowana
-  E27 (nie zawiera źródła światła) / 230V | 1 x 15W (max)
-  400 wys. | 250 szer. | 250 g.
-  1,6
-  IP 20



BELLA 1495



BELLA 1496



BELLA 1497

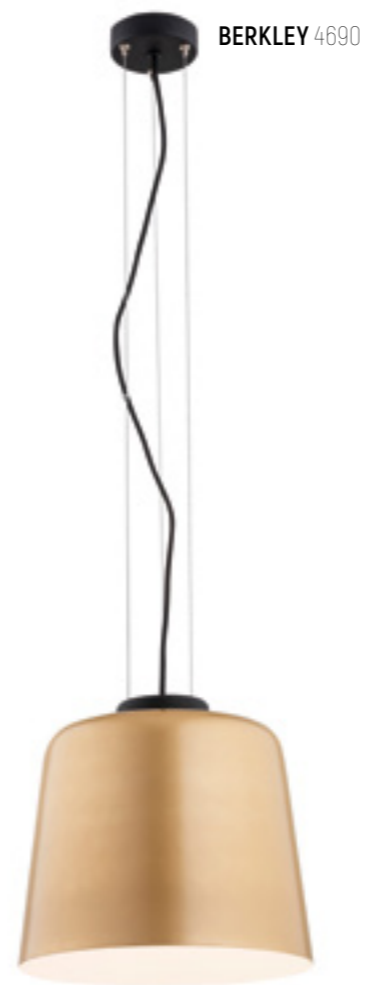

BERKLEY 4690

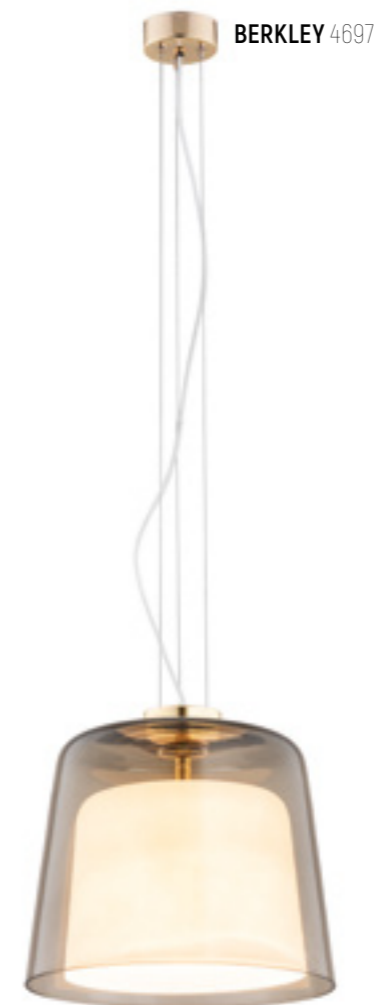



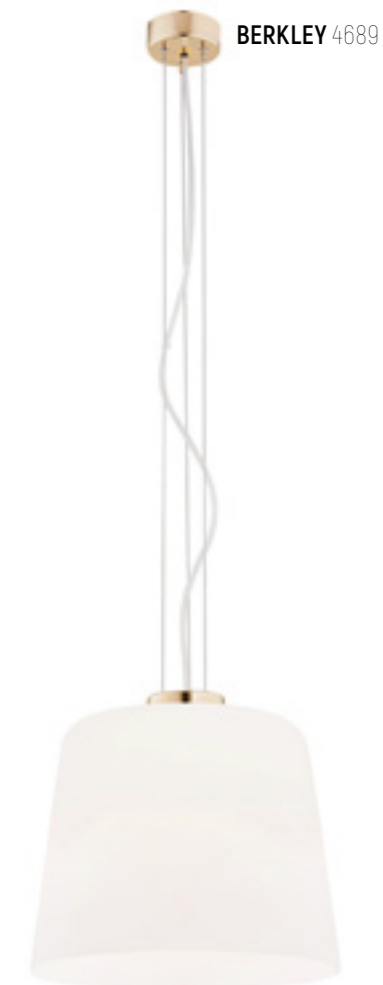





BERKLEY 4697





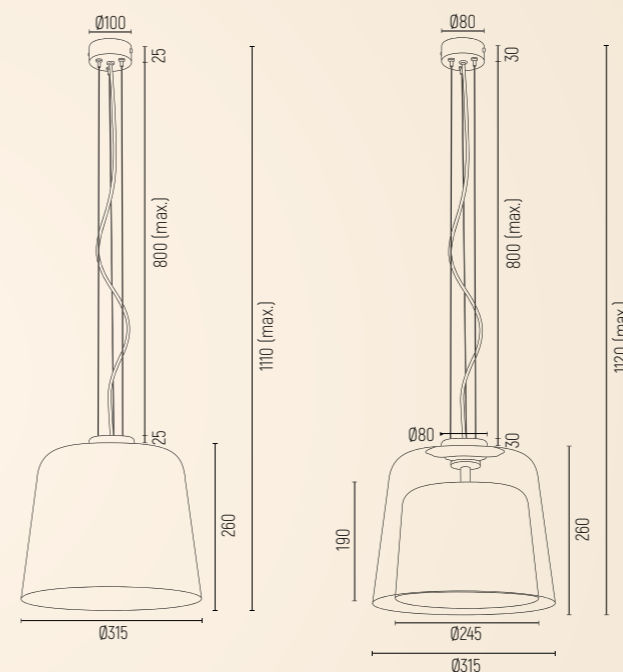
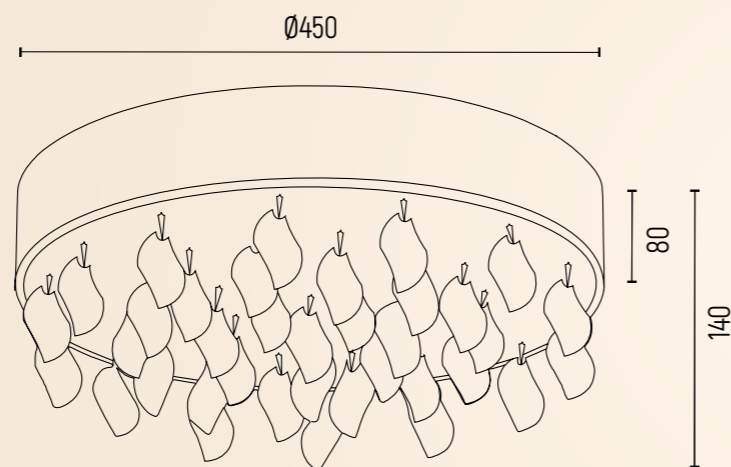

BERKLEY 4689

BELLA

-  1495 - czarna struktura, mleczny, transparentny
-  1496 - biały struktura, mleczny, transparentny
-  1497 - złoty struktura, mleczny, transparentny
-  plafon 3 pt.
-  stal lakierowana, plexi, kryształki
-  E27 (nie zawiera źródła światła) / 230V | 3 x 15W (max)
-  140 wys. | 450 szer. | 450 gł.
-  4
-  IP 20







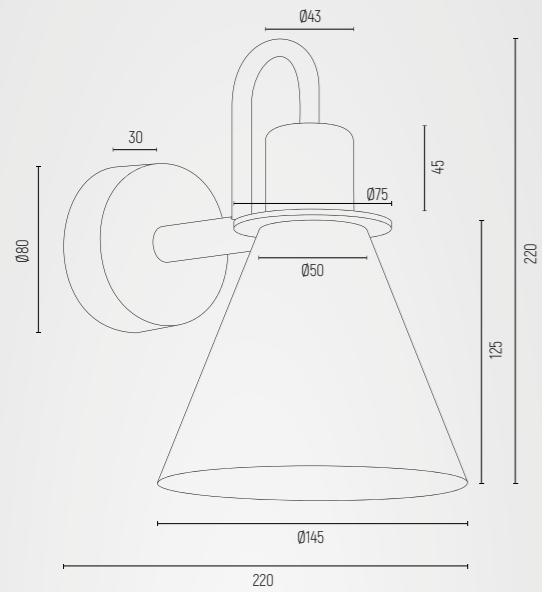







BERKLEY

-  4690 - złoty, biały, el. czarne struktura
-  4689 - opal mat, el. mosiądzowane
-  4697 - dymny, opal mat, el. mosiądzowane
-  lampa wisząca 1 pt.
-  4690 - szkło, stal lakierowana
-  4689, 4697 - szkło, stal mosiądzowana
-  E27 (nie zawiera źródła światła) / 230V | 1 x 15W (max)
-  4690, 4689 - przewód max. 800, całość 1100 wys. | 315 szer. | 315 gł.
-  4697 - przewód max. 800, całość 1120 wys. | 315 szer. | 315 gł.
-  4690, 4689 - 2,6
-  4697 - 3,7
-  IP 20



BEVERLY

-  4704 - biały struktura, el. mosiądzowane
-  4705 - biały struktura, el. chromowane
-  4706 - błękit mat, el. mosiądzowane
-  4707 - błękit mat, el. chromowane
-  4708 - czarny struktura, el. mosiądzowane
-  4709 - czarny struktura, el. chromowane
-  kinkiet 1 pł.
-  4704, 4706, 4708 - stal lakierowana, stal mosiądzowana
4705, 4707, 4709 - stal lakierowana, stal chromowana
-  E27 (nie zawiera źródła światła) / 230V | 1 x 15W (max)
-  220 wys. | 145 szer. | 220 gł.
-  0,6
-  IP 20
-  możliwość zamontowania włącznika na przyścienniku



BEVERLY 4704



BEVERLY 4705



BEVERLY 4706



BEVERLY 4707



BEVERLY 4708



BEVERLY 4709





BEVERLY 4680



BEVERLY 4681



BEVERLY 4682



BEVERLY 4683















BEVERLY 4687



BEVERLY 4688



BEVERLY

-  4680 – biały struktura, el. mosiędżowane
-  4681 – biały struktura, el. chromowane
-  4682 – błękit mat, el. mosiędżowane
-  4683 – błękit mat, el. chromowane
-  4687 – czarny struktura, el. mosiędżowane
-  4688 – czarny struktura, el. chromowane
-  lampa wisząca 1 pt.
-  4680, 4682, 4687 – stal lakierowana, stal mosiędżowana
4681, 4683, 4688 – stal lakierowana, stal chromowana
-  E27 (nie zawiera źródła światła) / 230V | 1 x 15W (max)
-  wys. 1000 [przewód max 800] / szer. 145 / gt. 145
-  0,4
-  IP 20

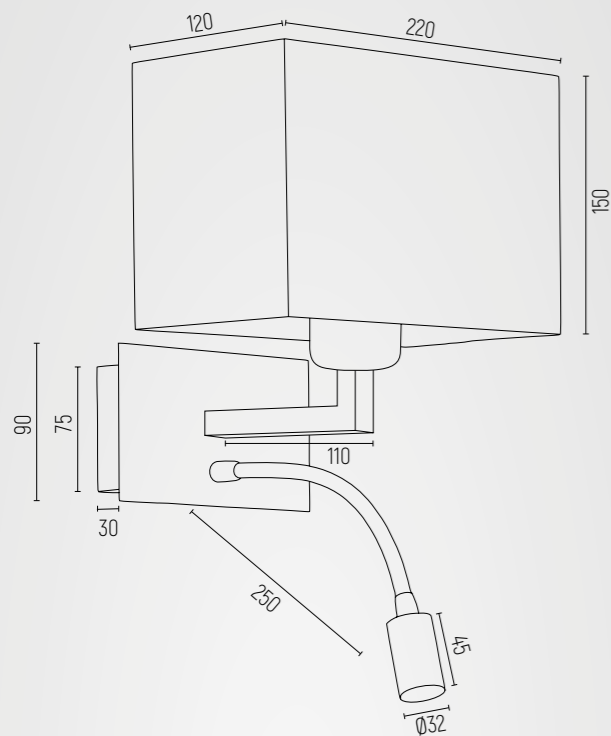

BILL

-  kinkiet 2 pt.
-  E27 (nie zawiera źródła światła) / 230V + LED (zintegrowany) / 230V / 3000K | 1 x 15W (max) + 1 x 4,5W
-  max 480 wys. | 220 szer. | 150 gł.
-  0,94
-  IP 20
-  możliwość regulacji punktowej
-  **1040** - biały, mosiądz szczotkowany, czarny mat
-  **1041** - czarny, mosiądz szczotkowany, czarny mat
-  abażur welur, mosiądz, stal lakierowana
-  **1051** - biały, czarny mat, el. mosiądzowane
-  **1042** - czarny, czarny mat, el. mosiądzowane
-  abażur welur, stal lakierowana, stal mosiądzowana
-  **1043** - beżowy, czarny mat
-  abażur welur, stal lakierowana
-  **1053** - ciemnoszary, chrom
-  abażur welur, stal chromowana



BILL 1040



BILL 1041



BILL 1043



BILL 1051



BILL 1042



BILL 1053



BODRUM 1251



BODRUM 1252



BODRUM 1253

BODRUM

- 1251 - biały struktura
- 1252 - chrom
- 1253 - czarny struktura
- lampa wisząca 3 pt.
- 1251, 1253 - stal lakierowana, szkło
1252 - stal chromowana, szkło
- E27 (nie zawiera źródła światła) / 230V | 3 x 15W (max)
- 1560 (łańcuch 1000) wys. | 300 szer. | 300 g.
- 5,5
- IP 20

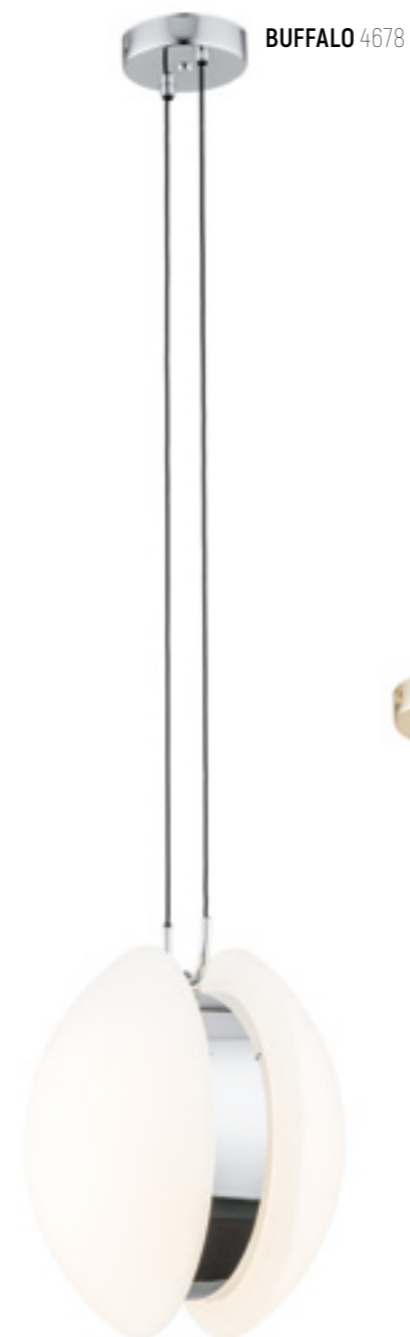
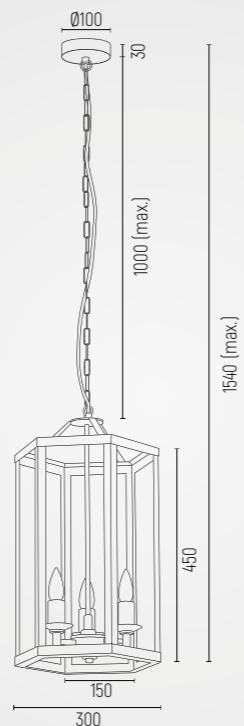

BUFFALO 4678

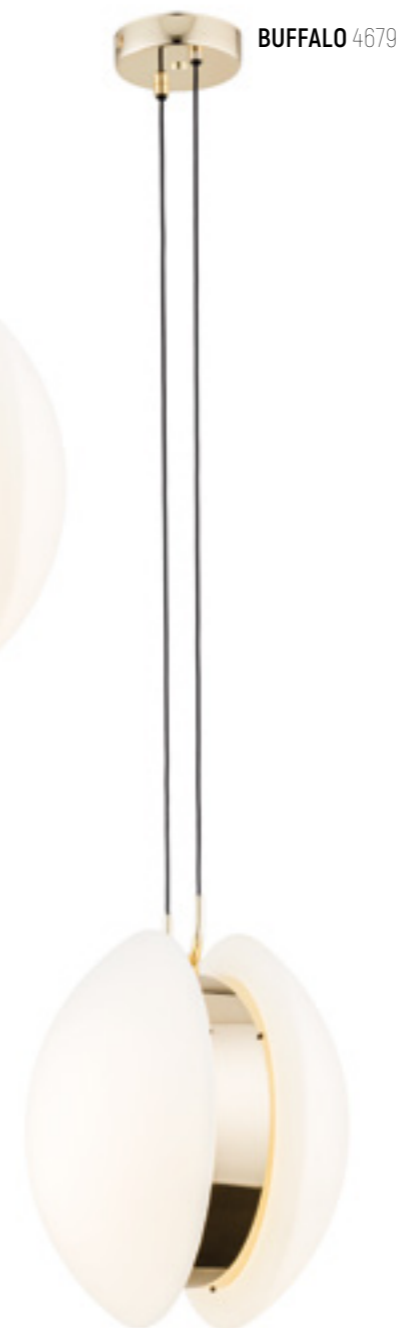

BUFFALO 4679



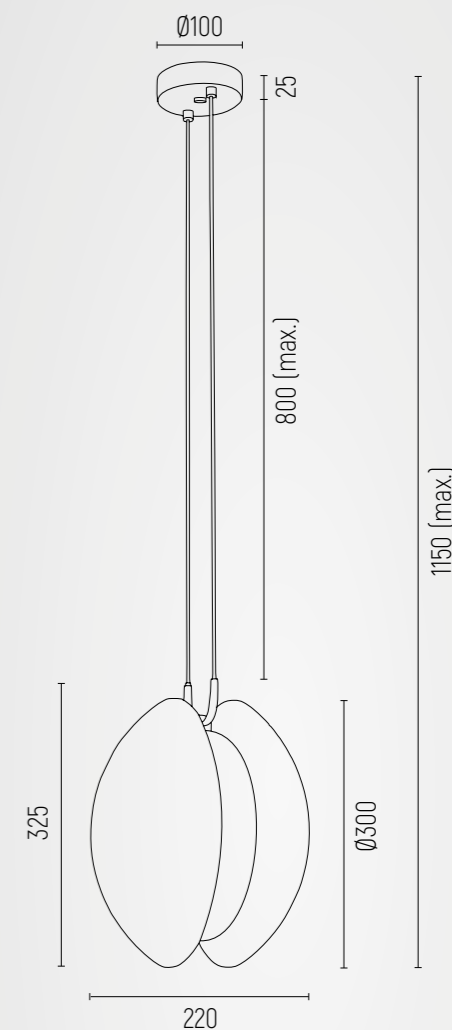

BUFFALO

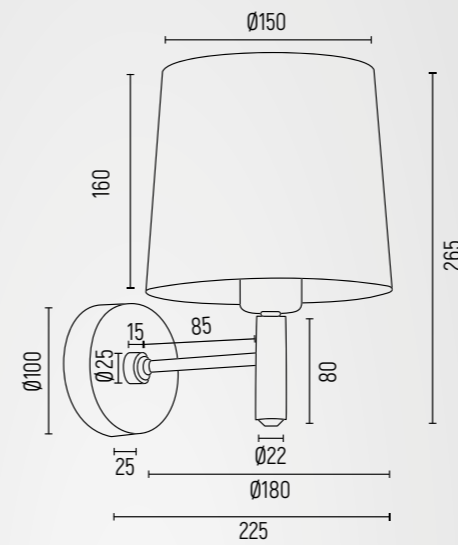
- 4678 - opal mat, el. chromowane
- 4679 - opal mat, el. mosiężowane
- lampa wisząca 1 pt.
- 4678 - szkło, stal chromowana
4679 - szkło, stal mosiężowana
- E27 (nie zawiera źródła światła) / 230V | 1 x 15W (max)
- przewód max. 800, całość 1150 wys. | 300 szer. | 220 g.
- 2,7
- IP 20





BOLZANO PLUS BOLZANO

-  4725 - ciemnoszary, chrom
-  4726 - czarny, chrom
-  4760 - śmietankowy, chrom
-  3908 - granat, chrom
-  3909 - różowy, chrom
-  3910 - błękitny, chrom
-  kinkiet 1 pt.
-  abażur welur, stal chromowana
-  E27 (nie zawiera źródła światła) / 230V | 1 x 15W (max)
-  265 wys. | 180 szer. | 225 gł.
-  0,8
-  IP 20
-  możliwość zamontowania włącznika na przyścienniku



BOLZANO PLUS 4725



BOLZANO 3908



BOLZANO PLUS 4726



BOLZANO 3909



BOLZANO PLUS 4760



BOLZANO 3910



BOLZANO PLUS 6107



BOLZANO PLUS 6108



BOLZANO PLUS 6114



BOLZANO 1381



BOLZANO 1382



BOLZANO 1383

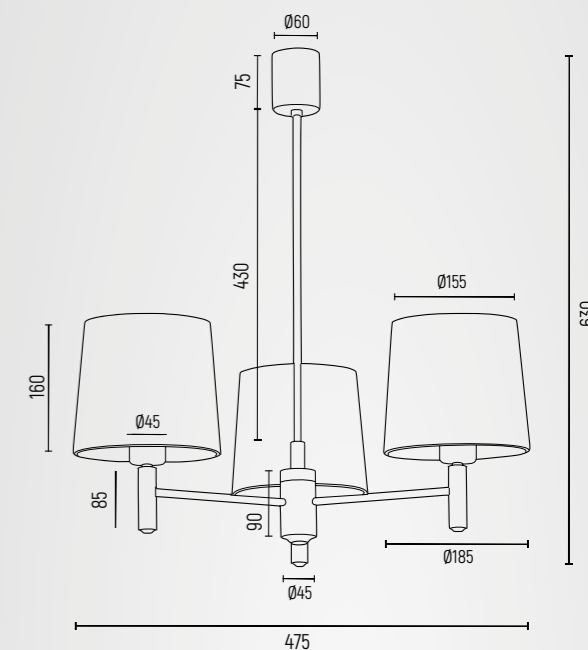

BOLZANO PLUS BOLZANO

-  6107 – ciemnoszary, chrom
-  6108 – czarny, chrom
-  6114 – śmietankowy, chrom
-  1381 – granat, chrom
-  1382 – różowy, chrom
-  1383 – błękitny, chrom
-  żyrandol 3 pł.
-  abażur welur, stal chromowana
-  E27 (nie zawiera źródła światła) / 230V | 3 x 15W (max)
-  630 wys. | 475 szer. | 475 gł.
-  2,6
-  IP 20
-  możliwość modyfikacji - włączanie 1+2



BOLZANO PLUS 2108

BOLZANO PLUS 2110



BOLZANO PLUS 2104



BOLZANO 2074



BOLZANO 2075



BOLZANO 2076

BOLZANO PLUS BOLZANO

-  2108 - ciemnoszary, chrom
-  2104 - czarny, chrom
-  2110 - śmietankowy, chrom
-  2074 - granat, chrom
-  2075 - różowy, chrom
-  2076 - błękitny, chrom
-  żyrandol 5 pt.
-  abażur welur, stal chromowana
-  E27 (nie zawiera źródła światła) / 230V | 5 x 15W (max)
-  630 wys. | 710 szer. | 710 gł.
-  3,4
-  IP 20
-  możliwość modyfikacji na włączenie 3+2

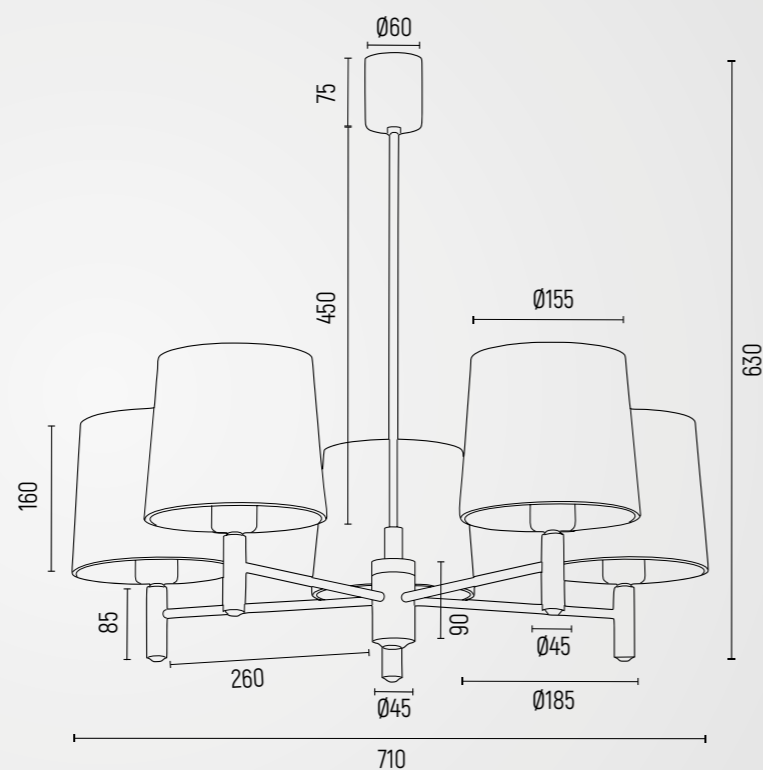



BURGOS 4211



BURGOS 4212



BURGOS 4213



BURGOS 1465













BURGOS 1466



BURGOS 1467

BURGOS

-  4211 - opal mat, chrom
-  4212 - opal mat, msiądz
-  4213 - opal mat, czarny struktura, el.mosiądzowane
-  lampa wisząca 1 pt.
-  4211 - szkło, stal chromowana
-  4212 - szkło, stal msiądzowana
-  4213 - szkło, stal lakierowana
-  E27 (nie zawiera źródła światła) / 230V | 1 x 15W (max)
-  przewód max. 800, całość 1130 wys. | 100 szer. | 100 gł.
-  1
-  IP 20

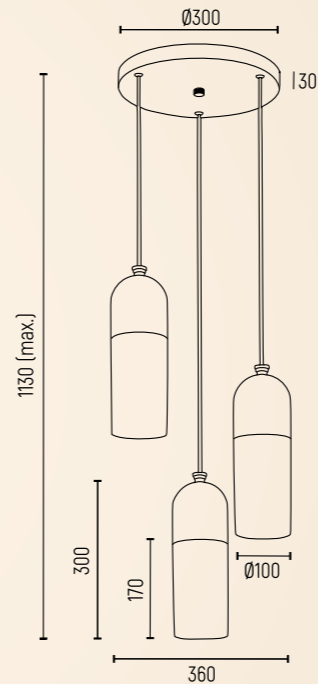
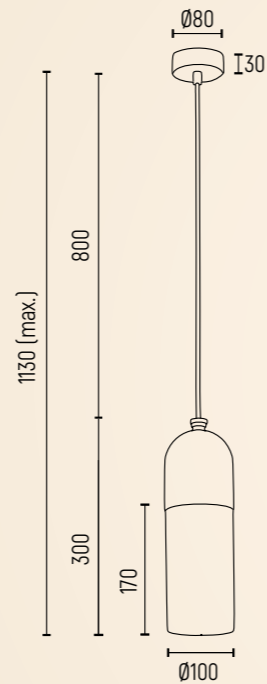

BURGOS

-  1465 - opal mat, chrom
-  1466 - opal mat, msiądz
-  1467 - opal mat, czarny struktura, el.mosiądzowane
-  lampa wisząca 3 pt. okrągła podsufitka
-  1465 - szkło, stal chromowana
-  1466 - szkło, stal msiądzowana
-  1467 - szkło, stal lakierowana
-  E27 (nie zawiera źródła światła) / 230V | 3 x 15W (max)
-  przewód max. 800, całość 1130 wys. | 360 szer. | 360 gł.
-  3,8
-  IP 20
-  możliwość modyfikacji na włączenie 1+2

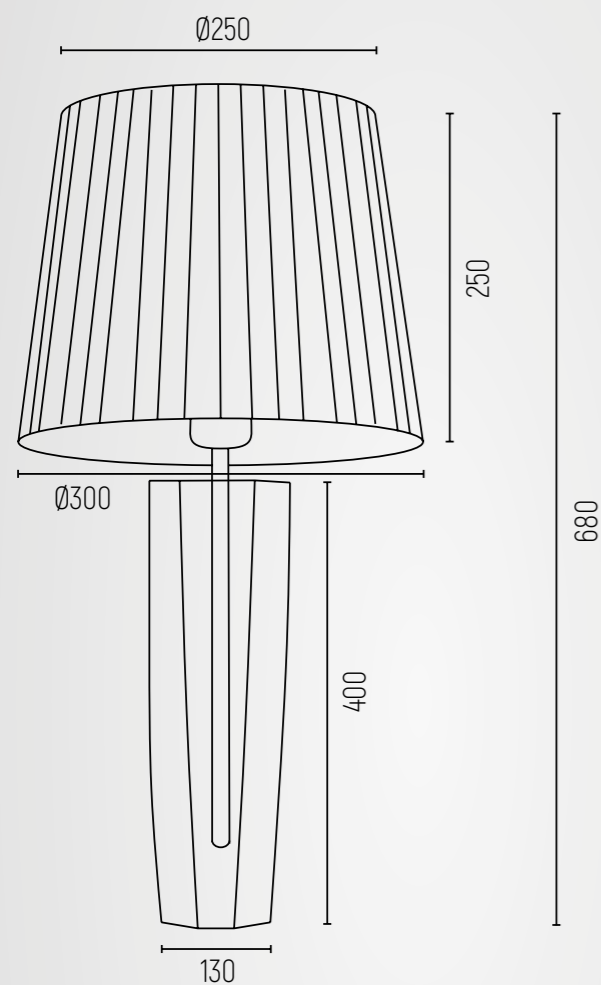



CALIGARI 3913



CALIGARI 3914



CALIGARI

-  **3913** - czerwony, transparentny, chrom
-  **3914** - biały, transparentny, chrom
-  lampa stołowa 1 pt.
-  abażur, szkło, stal chromowane
-  E27 (nie zawiera źródła światła) / 230V | 1 x 15W (max)
-  680 wys. | 300 szer. | 300 g.
-  3,3
-  IP 20
-  możliwość zastawania stali mosiędżowanej zamiast stali chromowanej



CALVADOS

- 3186** - antracyt struktura
- 3187** - biały struktura
- 3188** - czarny struktura
- 3189** - brąz struktura
- lampa wisząca 1 pt.
- stal lakierowana
- E27 (nie zawiera źródła światła) / 230V | 1 x 15W (max)
- 1250 (łańcuch 1000) wys. | 200 szer. | 200 g.
- 1
- IP 20

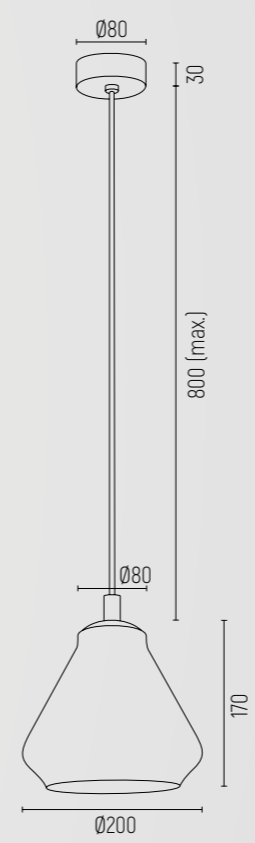
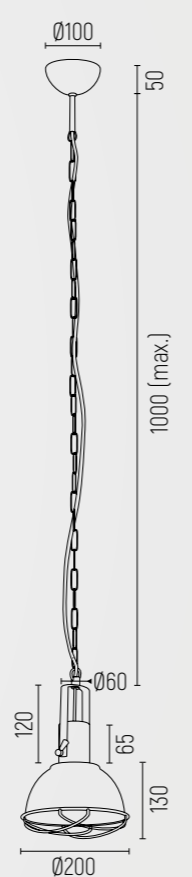

DECORATO

- transparentny, czarny mat
- szkło, stal lakierowana
- IP 20
- 4047** - lampa wisząca 1 pt.
- E27 (nie zawiera źródła światła) / 230V | 1 x 15W (max)
- 1000 (przewód 800) wys. | 200 szer. | 200 g.
- 0,8
- 854** - lampa wisząca 2 pt.
- E27 (nie zawiera źródła światła) / 230V | 2 x 15W (max)
- 1000 (przewód 800) wys. | 560 szer. | 200 g.
- 1,3

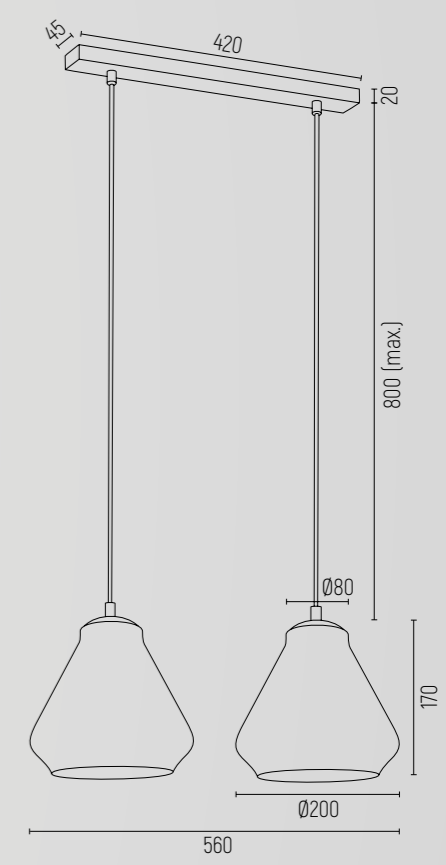

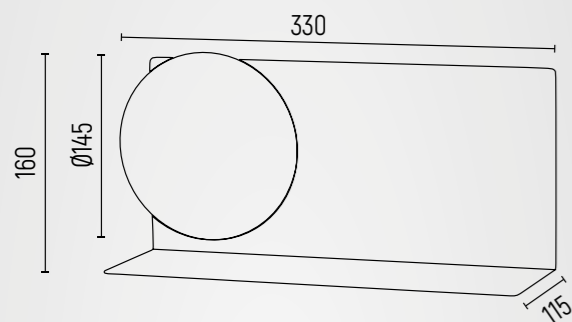

CALVIA 4241



CALVIA 4242



CALVIA 4243



CALVIA 4244



CALVIA 4245



CELIA 4249



CELIA 4250



CELIA 4251



CELIA 4252



CELIA 4253

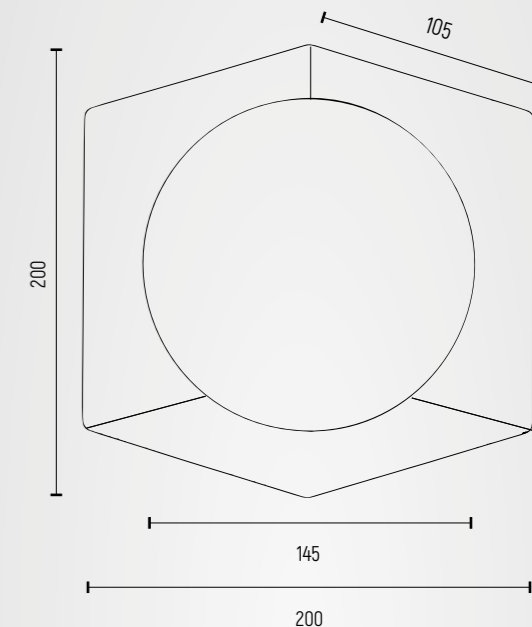

CALVIA

-  4241 - opal, biały struktura
-  4242 - opal, czarny struktura
-  4243 - opal, granat struktura
-  4244 - opal, szalwia struktura
-  4245 - opal, koral struktura
-  kinkiet 1 pt. z półką
-  szkło, stal lakierowana
-  LED (zintegrowany) / 230V / 1120 lm / 3000 K | 9 W
-  160 wys. | 330 szer. | 115 gł.
-  1,6
-  IP 20
-  możliwość zastosowania modułu LED o temperaturze barwowej 4000K - nieodpłatnie

CELIA

-  4249 - opal, biały struktura
-  4250 - opal, koral struktura
-  4251 - opal, szalwia struktura
-  4252 - opal, granat struktura
-  4253 - opal, czarny struktura
-  kinkiet / plafon 1 pt.
-  szkło, stal lakierowana
-  LED (zintegrowany) / 230V / 1120 lm / 3000 K | 9 W
-  200 wys. | 200 szer. | 50 gł.
-  0,6
-  IP 20
-  możliwość zastosowania modułu LED o temperaturze barwowej 4000K - nieodpłatnie

CLAVA

- złoty, czarny struktura
- abażur, stal lakierowana
- IP 20

- 4275** - kinkiet 1 pt.
- E27 (nie zawiera źródła światła) / 230V | 1 x 15W (max)
- max. 610, pozycja na zdjęciu 230 wys. | 260 szer. | 590 g.
- 0,6
- 897** - lampa wisząca 2 pt.
- E27 (nie zawiera źródła światła) / 230V | 2 x 15W (max)
- max. 1300, pozycja na zdjęciu 1000 wys. | 1050 szer. | 250 g.
- 1,2
- możliwość regulacji ramion/możliwość modyfikacji na włączenie 1+1

- 4274** - lampa biurkowa 1 pt.
- E27 (nie zawiera źródła światła) / 230V | 1 x 15W (max)
- 490 wys. | 250 szer. | 490 g.
- 2,4
- możliwość regulacji

- 1694** - lampa wisząca 4 pt.
- E27 (nie zawiera źródła światła) / 230V | 4 x 15W (max)
- max. 1150, na zdjęciu 950 wys. | 1050 szer. | 350 g.
- 2,4
- możliwość regulacji ramion/możliwość modyfikacji na włączenie 2+2

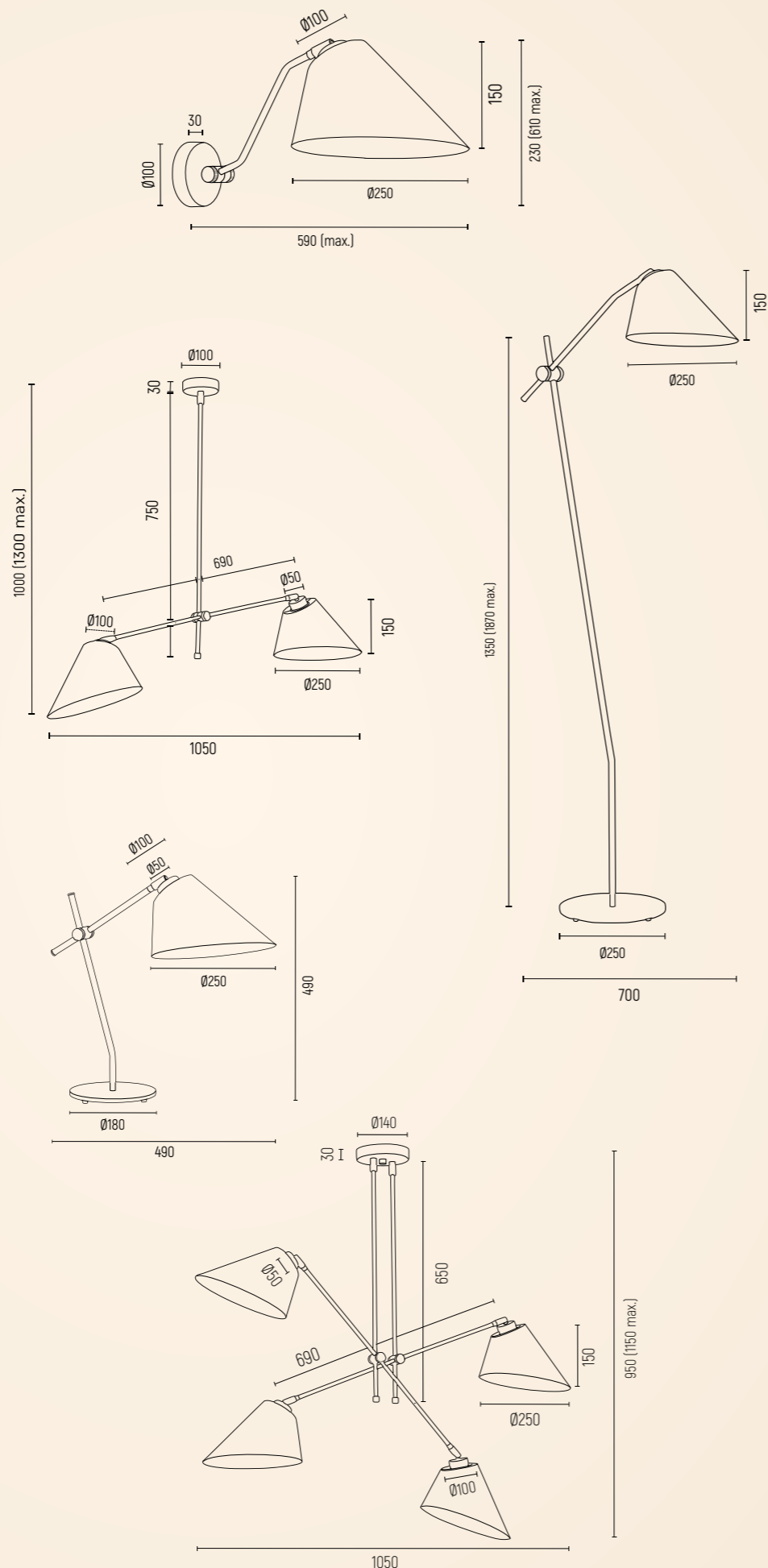

- 4270** - lampa podłogowa 1 pt.
- E27 (nie zawiera źródła światła) / 230V | 1 x 15W (max)
- 1350 (max 1870) wys. | 250 szer. | 700 g.
- 5,2
- możliwość regulacji



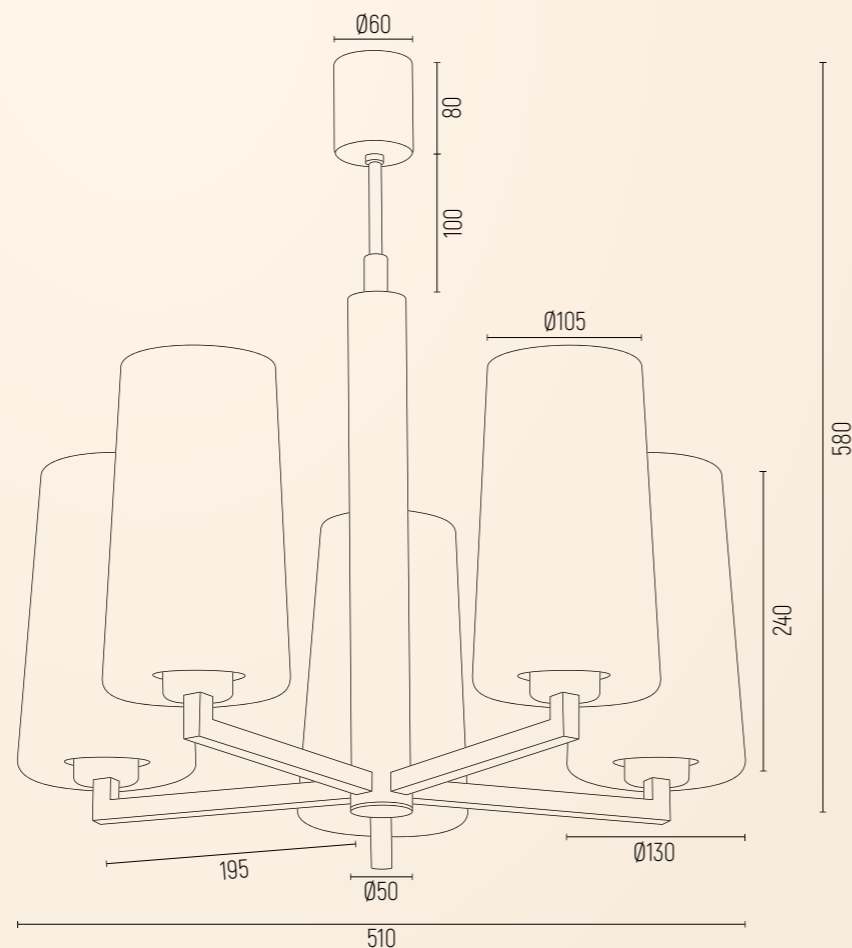
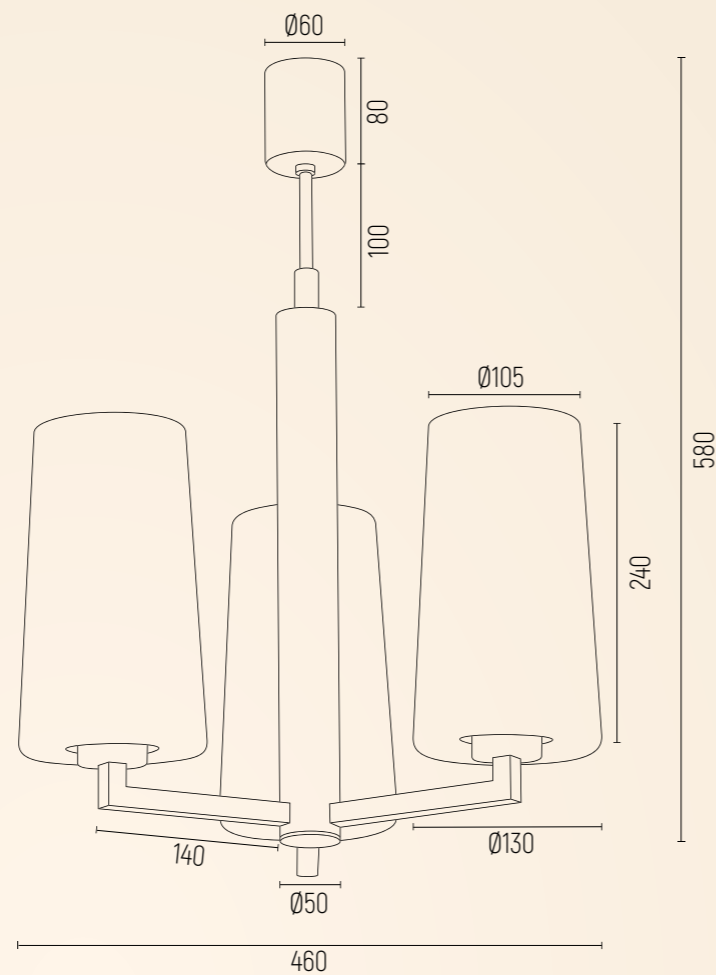
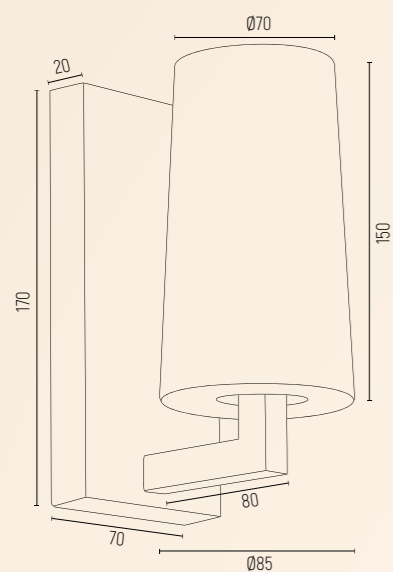

















CAMELOT PLUS

-  opal mat, czarny mat, mosiądz
-  szkło, stal lakierowana, stal mosiądzowana
-  IP 20

-  **8056** - kinkiet 1 pt.
-  E27 (nie zawiera źródła światła) / 230V | 1 x 15W (max)
-  190 wys. | 85 szer. | 140 g.
-  0,6

-  **6143** - żyrandol 3 pt.
-  E27 (nie zawiera źródła światła) / 230V | 3 x 15W (max)
-  580 wys. | 460 szer. | 460 g.
-  4,5
-  możliwość modyfikacji na włączanie 1+2

-  **2114** - żyrandol 5 pt.
-  E27 (nie zawiera źródła światła) / 230V | 5 x 15W (max)
-  580 wys. | 510 szer. | 510 g.
-  6
-  możliwość modyfikacji na włączanie 3+2





CAMELOT 3358



CAMELOT 1224



CAMELOT 2053

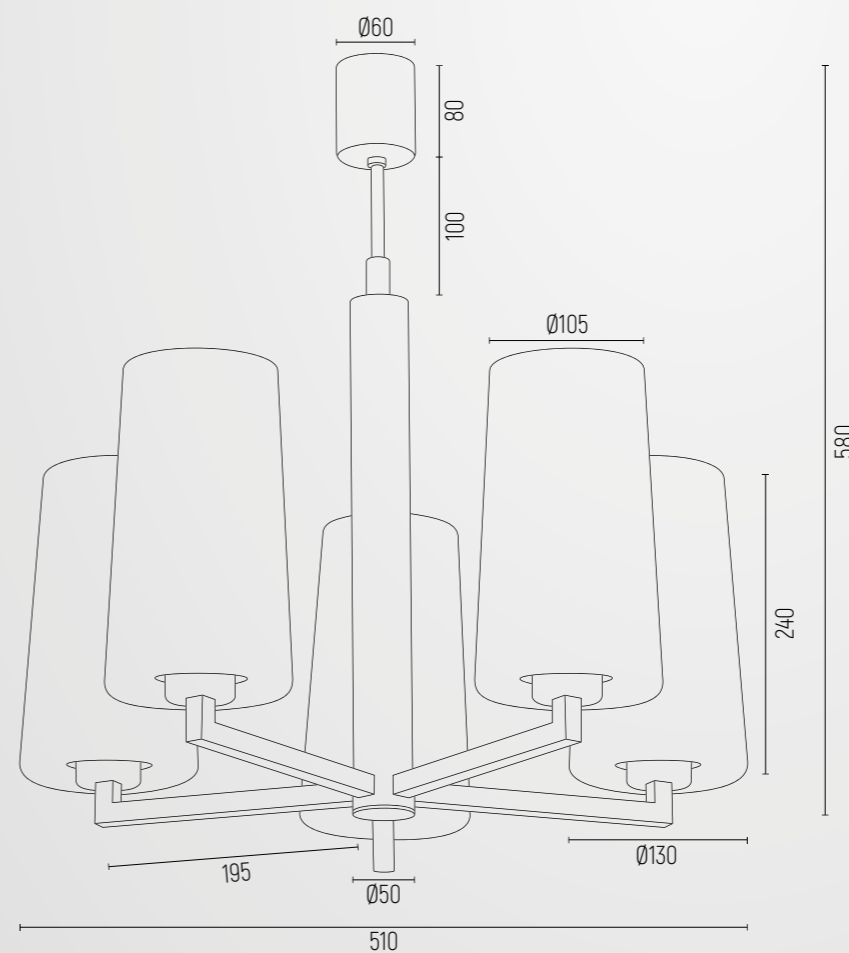
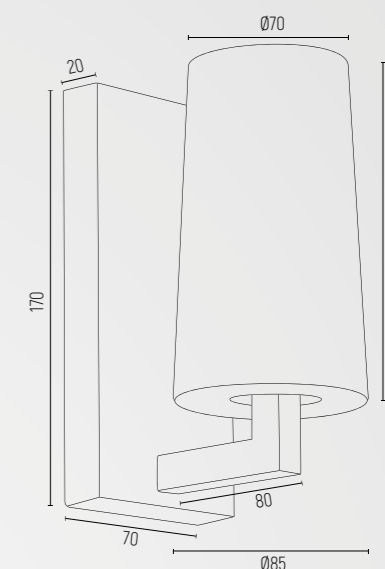
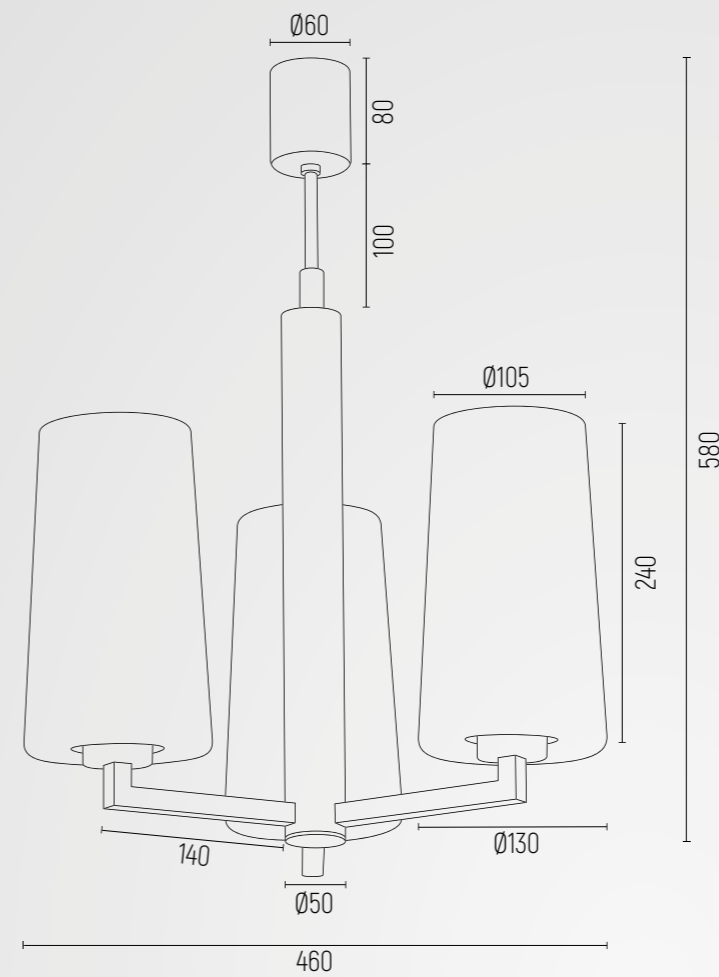

CAMELOT

- opal mat, chrom
- szkło, stal chromowana
- IP 20









- 3358** – kinkiet 1 pt.
- E27 (nie zawiera źródła światła) / 230V | 1 x 15W (max)
- 190 wys. | 85 szer. | 140 g.
- 0,6

- 1224** – żyrandol 3 pt.
- E27 (nie zawiera źródła światła) / 230V | 3 x 15W (max)
- 580 wys. | 460 szer. | 460 g.
- 4,5
- możliwość modyfikacji na włączanie 1+2

- 2053** – żyrandol 5 pt.
- E27 (nie zawiera źródła światła) / 230V | 5 x 15W (max)
- 580 wys. | 510 szer. | 510 g.
- 6
- możliwość modyfikacji na włączanie 3+2



CAMERON

-  5041 - opal mat, czarny mat, mosiądz
-  5043 - opal mat, mosiądz
-  lampa wisząca 8 pt.
-  5041 - szkło, stal lakierowana, stal mosiądzowana
5043 - szkło, stal mosiądzowana
-  E27 (nie zawiera źródła światła) / 230V | 8 x 15W (max)
-  765 wys. | 1160 szer. | 1160 gt.
-  4,8
-  IP 20
-  możliwość regulacji | możliwość wykonania stelażu żyrandola w całości ze stali lakierowanej

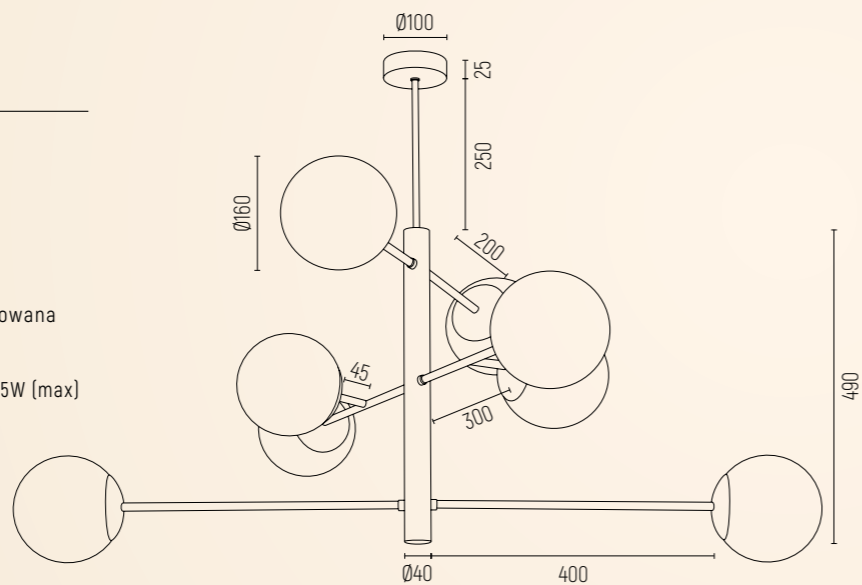

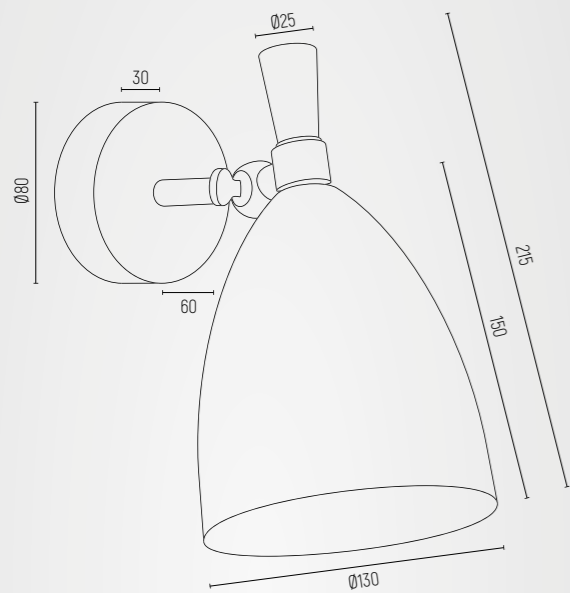

CHARLOTTE 4699



CHARLOTTE 4700



CHARLOTTE 4701



CHARLOTTE 4684







CHARLOTTE 4685



CHARLOTTE 4686

CHARLOTTE

-  4699 - biały struktura, el. mosiądzowane
-  4700 - błękit mat, el. mosiądzowane
-  4701 - czarny struktura, el. mosiądzowane
-  kinkiet 1 pt.
-  stal lakierowana, stal mosiądzowana
-  E27 (nie zawiera źródła światła) / 230V | 1 x 15W (max)
-  max 215 wys. | 130 szer. | max 300 g.
-  0,6
-  IP 20
-  możliwość regulacji | możliwość zamontowania włącznika na przycienniku | możliwość zastosowania el. chromowanych lub lakierowanych zamiast el. mosiądzowanych

CHARLOTTE

-  4684 - biały struktura, el. mosiądzowane
-  4685 - błękit mat, el. mosiądzowane
-  4686 - czarny struktura, el. mosiądzowane
-  lampa wisząca 1 pt.
-  stal lakierowana, stal mosiądzowana
-  E27 (nie zawiera źródła światła) / 230V | 1 x 15W (max)
-  max 430 wys. | 215 szer. | 130 g.
-  0,6
-  IP 20
-  lampa wisząca na sztycy, możliwość regulacji | możliwość zastosowania el. chromowanych lub lakierowanych zamiast el. mosiądzowanych

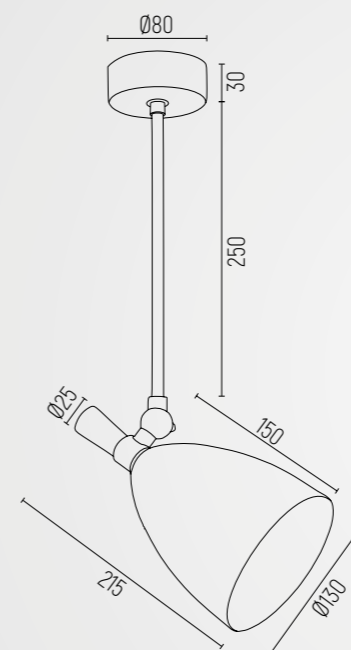



CHARLOTTE 6148



CHARLOTTE 6149











CHARLOTTE 2117









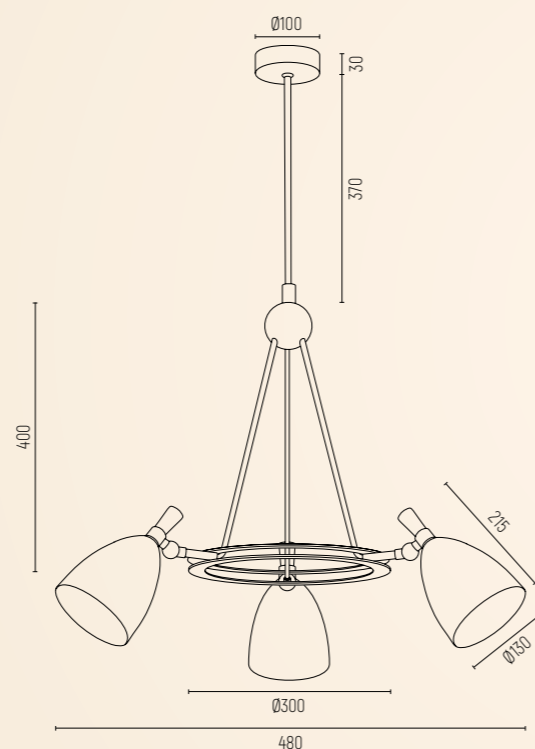

CHARLOTTE 2118

CHARLOTTE

-  6148 - biały struktura, el. mosiądzowane
-  6149 - czarny struktura, el. mosiądzowane
-  żyrandol 3 pt.
-  stal lakierowana, stal mosiądzowana
-  E27 (nie zawiera źródła światła) / 230V | 3 x 15W (max)
-  950 wys. | 480 szer. | 480 g.
-  3,1
-  IP 20
-  możliwość regulacji, możliwość modyfikacji na włączanie 1+2 | możliwość zastosowania el. chromowanych lub lakierowanych zamiast el. mosiądzowanych



CHARLOTTE

-  2117 - biały struktura, el. mosiądzowane
-  2118 - czarny struktura, el. mosiądzowane
-  żyrandol 5 pt.
-  stal lakierowana, stal mosiądzowana
-  E27 (nie zawiera źródła światła) / 230V | 5 x 15W (max)
-  920 wys. | 750 szer. | 750 g.
-  3,5
-  IP 20
-  możliwość regulacji, możliwość modyfikacji na włączanie 2+3 | możliwość zastosowania el. chromowanych lub lakierowanych zamiast el. mosiądzowanych

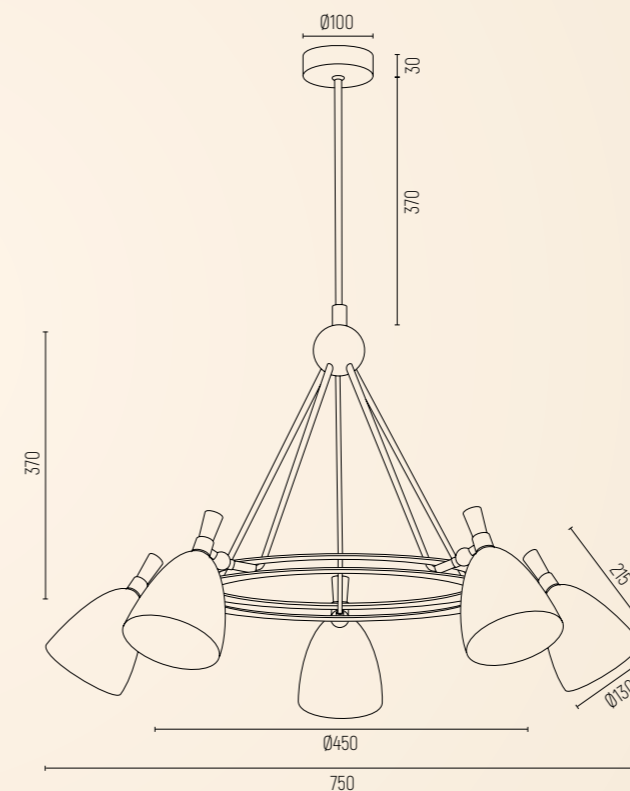



CORSO

- 3878, 3883** - biały struktura
- 3879, 3882** - czarny struktura
- 3880, 3881** - chrom
- 3878, 3883, 3879, 3882** - stal lakierowana
3880, 3881 - stal chromowana
- E27 (nie zawiera źródła światła) / 230V | 1 x 15W (max)

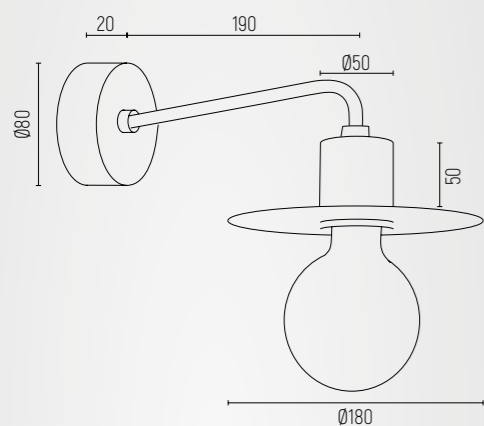

- 3878, 3879, 3880** - kinkiet 1 pt.
- 250 wys. | 180 szer. | 270 gt.
- 0,8

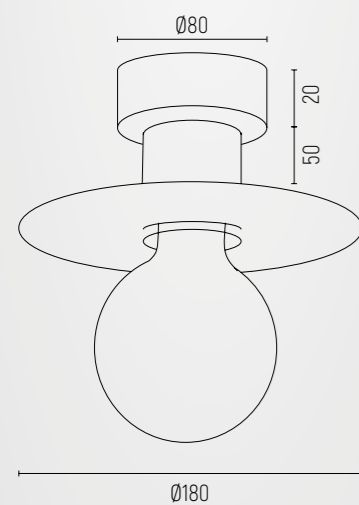

- 3882, 3883, 3881** - plafon 1 pt.
- 200 wys. | 180 szer. | 180 gt.
- 0,5



CORSO 3878



CORSO 3879



CORSO 3880



CORSO 3882



CORSO 3883



CORSO 3881

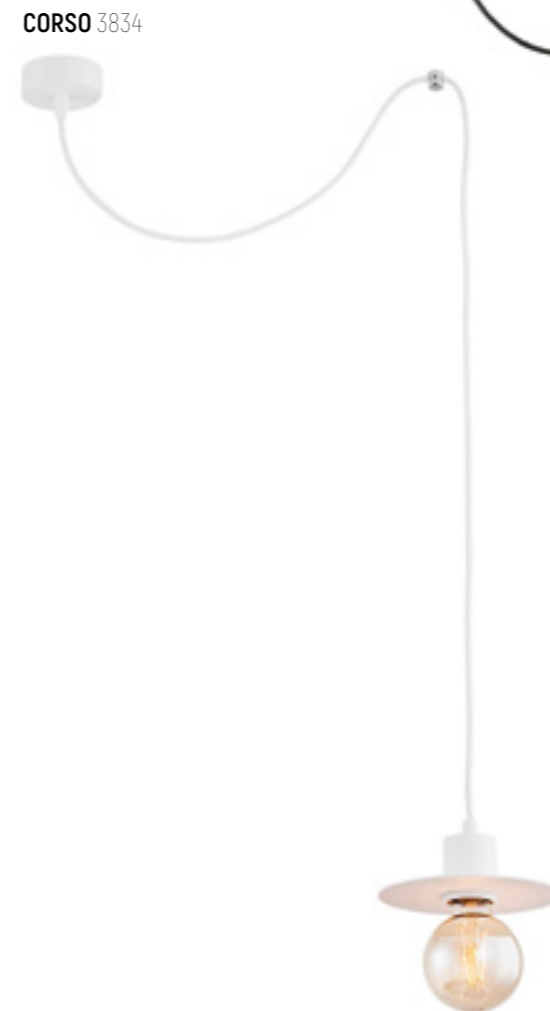

CORSO 3834



CORSO 3835



CORSO 3836

CORSO

- 3834** - biały struktura
- 3835** - czarny struktura
- 3836** - chrom
- lampa wisząca 1 pt.
- 3834, 3835** - stal lakierowana
3836 - stal chromowana
- E27 (nie zawiera źródła światła) / 230V | 1 x 15W (max)
- max. 2000 wys. | ok. 600 szer. | ok. 600 gt.
- 0,8
- IP 20

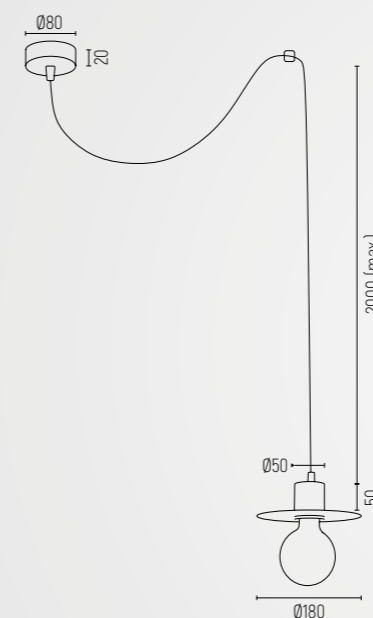

CORSO 1376



CORSO 1377



CORSO 1378



CORSO 2077



CORSO 2078



CORSO 2079

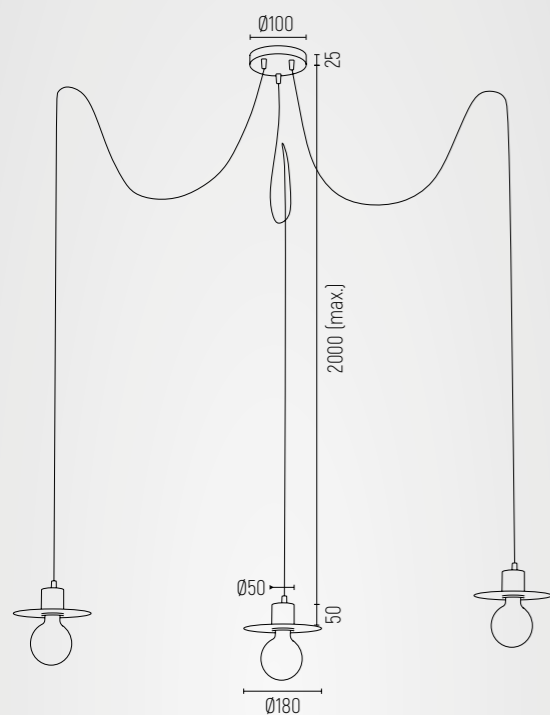

CORSO

- 1376 - biały struktura
- 1377 - czarny struktura
- 1378 - chrom
- 🕸️ lampa wisząca 3 pt. "pająk"
- 📏 1376, 1377 - stal lakierowana
1378 - stal chromowana
- 💡 E27 (nie zawiera źródła światła) / 230V | 3 x 15W (max)
- 📏 max. 2000 wys. | ok. 700 szer. | ok. 700 g.
- ⚖️ 2,3
- 🛡️ IP 20
- ⊕ możliwość modyfikacji na włączenie 1+2

CORSO



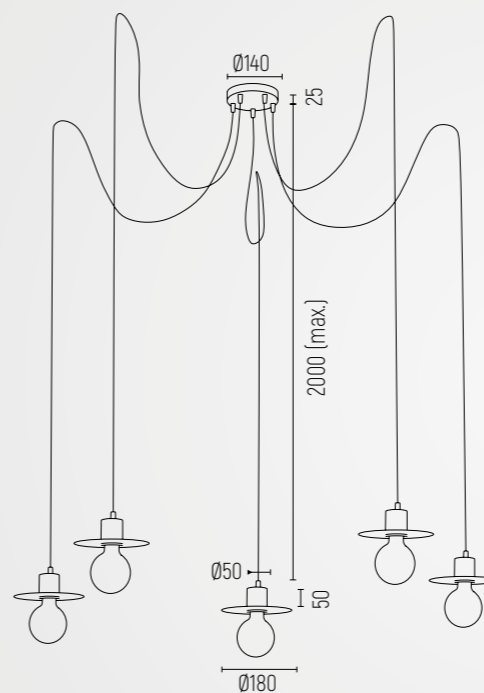

- 2077 - biały struktura
- 2078 - czarny struktura
- 2079 - chrom
- 🕸️ lampa wisząca 5 pt. "pająk"
- 📏 2077, 2078 - stal lakierowana
2079 - stal chromowana
- 💡 E27 (nie zawiera źródła światła) / 230V | 5 x 15W (max)
- 📏 max. 2000 wys. | ok. 700 szer. | ok. 700 g.
- ⚖️ 3,5
- 🛡️ IP 20
- ⊕ możliwość modyfikacji na włączenie 3+2



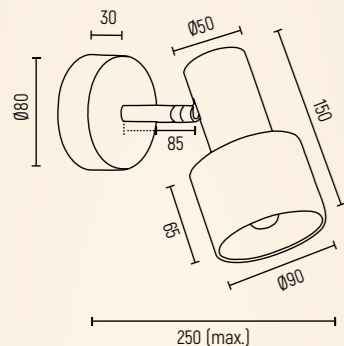



DORIA

-  **4264, 4256** - biały struktura, el. mosiądzowane
-  **4265, 4257** - czarny struktura, el. mosiądzowane
-  **4315, 4276** - szalwia struktura, el. mosiądzowane
-  stal lakierowana, stal mosiądzowana
-  E27 (nie zawiera źródła światła) / 230V | 1 x 15W (max)

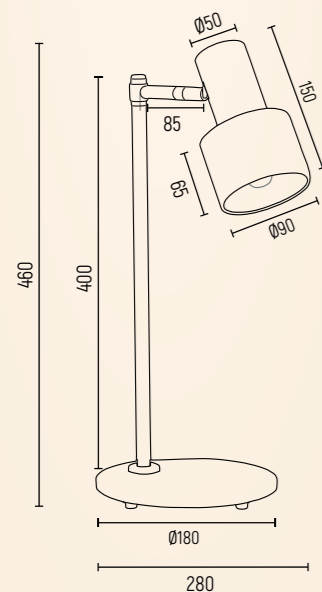

-  **4264, 4265, 4315** - kinkiet 1 pt.
-  160 wys. | 90 szer. | max.250 gł.
-  0,6
-  możliwość regulacji, możliwość zamontowania włącznika na przyścienniku | możliwość zastosowania el. chromowanych lub lakierowanych zamiast el. mosiądzowanych



-  **4256, 4257, 4276** - lampa biurkowa 1 pt.
-  460 wys. | 180 szer. | 280 gł.
-  2,2
-  możliwość regulacji | możliwość zastosowania el. chromowanych lub lakierowanych zamiast el. mosiądzowanych

DORIA 4264



DORIA 4256

DORIA 4265



DORIA 4257

DORIA 4315



DORIA 4276



DORIA 4258



DORIA 4259





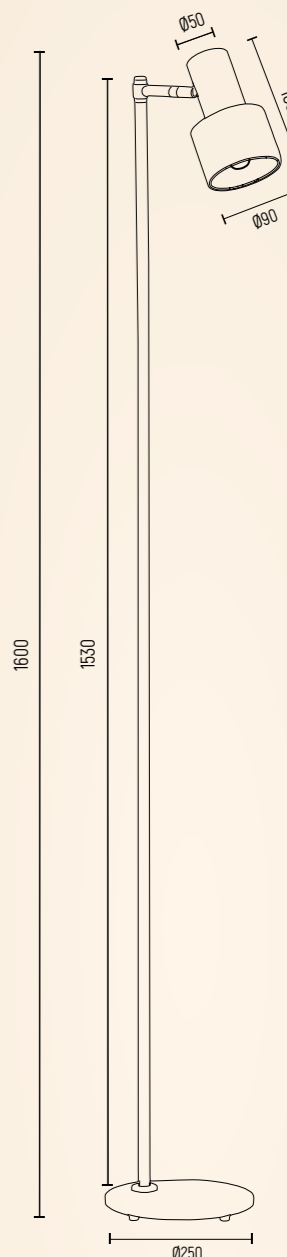

DORIA 4271







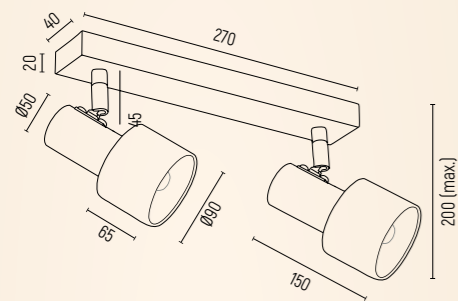

DORIA

-  **4258** - biały struktura, el. mosiądzowane
-  **4259** - czarny struktura, el. mosiądzowane
-  **4271** - szalwia struktura, el. mosiądzowane
-  lampa podłogowa 1 pt.
-  stal lakierowana, stal mosiądzowana
-  E27 (nie zawiera źródła światła) / 230V | 1 x 15W (max)
-  1600 wys. | 250 szer. | 250 gł.
-  5,16
-  możliwość regulacji | możliwość zastosowania el. chromowanych lub lakierowanych zamiast el. mosiądzowanych





DORIA

-  **927, 6008** – biały struktura, el. mosiądzowane
-  **925, 6006** – czarny struktura, el. mosiądzowane
-  **926, 6007** – szalwia struktura, el. mosiądzowane
-  stal lakierowana, stal mosiądzowana

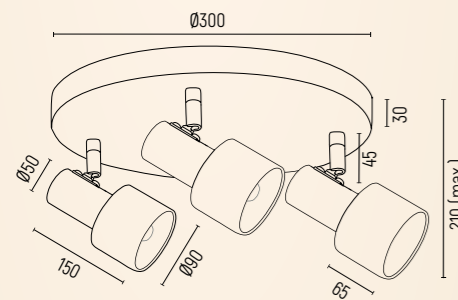

-  **927, 925, 926** – plafon 2 pt.
-  E27 (nie zawiera źródła światła) / 230V | 2 x 15W (max)
-  max 200 wys. | max 460 szer. | 150 gt.
-  1,2
-  możliwość regulacji | możliwość zastosowania el. chromowanych lub lakierowanych zamiast el. mosiądzowanych



-  **6008, 6006, 6007** – plafon 3 pt.
-  E27 (nie zawiera źródła światła) / 230V | 3 x 15W (max)
-  max 210 wys. | max 470 szer. | max 470 gt.
-  1,8
-  możliwość regulacji | możliwość zastosowania el. chromowanych lub lakierowanych zamiast el. mosiądzowanych

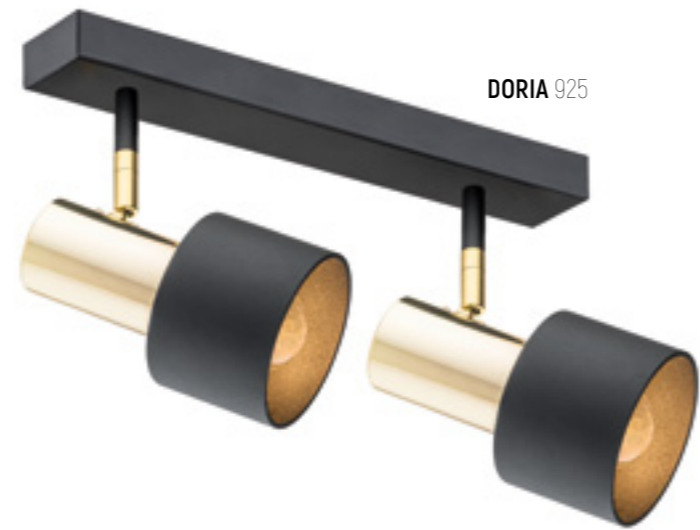

DORIA 925

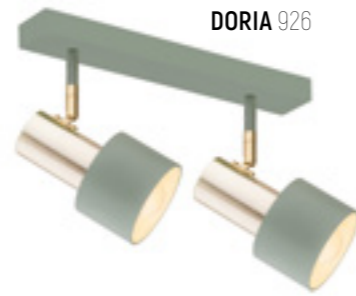

DORIA 926



DORIA 927

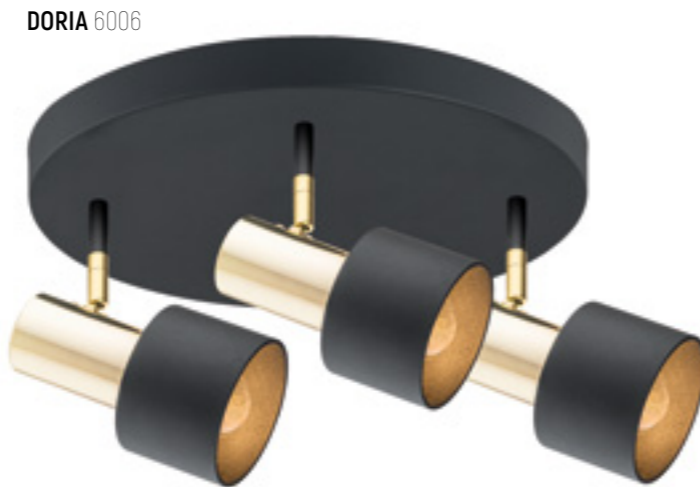

DORIA 6006



DORIA 6007

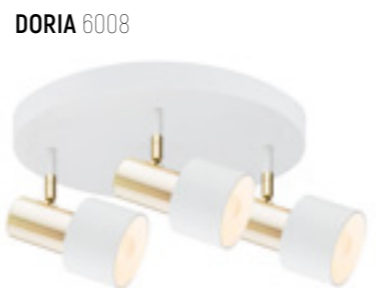

DORIA 6008



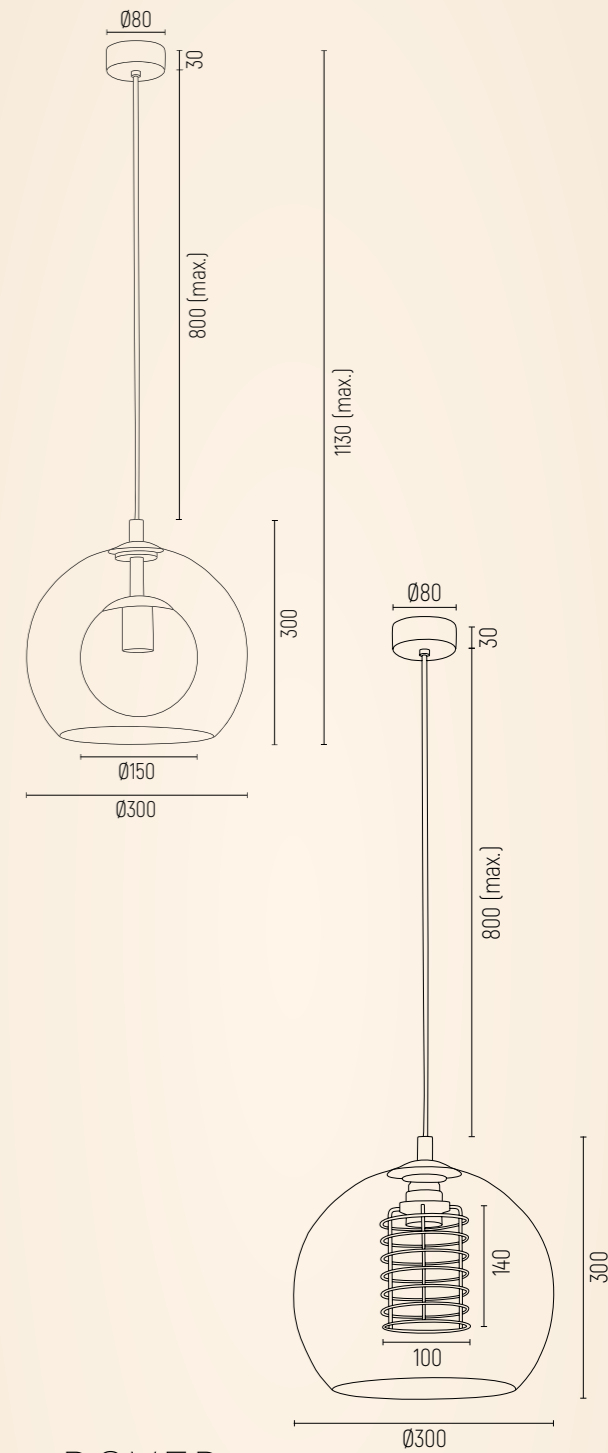

DOVER

-  **4673, 4674** – transparent, el. mosiądzowane
-  lampa wisząca 1 pt.
-  szkło, stal mosiądzowana
-  E27 (nie zawiera źródła światła) / 230V | 1 x 15W (max)
-  przewód max. 800, całość 1130 wys. | 300 szer. | 300 gł.
-  1,3/1,5
-  IP 20













DETROIT 4734

DETROIT 4735



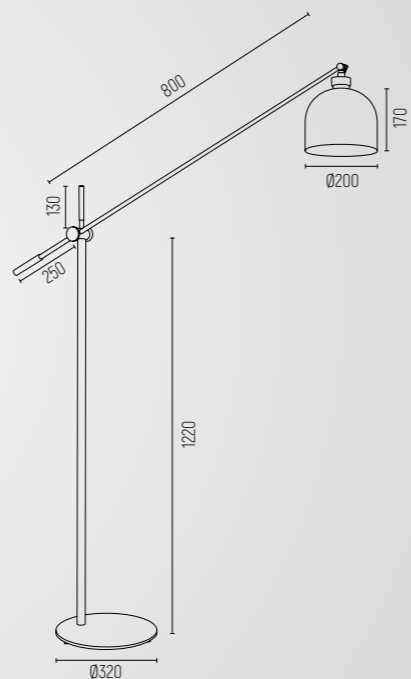

DETROIT 4736

DETROIT

-  **4734** - biały struktura, el. mosiądzowane
-  **4735** - czarny struktura, el. mosiądzowane
-  **4736** - szalwia struktura, el. mosiądzowane
-  lampa podłogowa 1 pt.
-  stal lakierowana, stal mosiądzowana
-  E27 (nie zawiera źródła światła) / 230V | 1 x 15W (max)
-  2200 wys. / 320 gł. / 1400 gł.
-  7,5
-  IP 20
-  możliwość regulacji | możliwość zastosowania el. chromowanych lub lakierowanych zamiast el. mosiądzowanych



ERBA

-  **632, 630** - biały mat
-  **633, 631** - czarny mat
-  stal lakierowana
-  E27 (nie zawiera źródła światła) / 230V | 1 x 15W (max)
-  IP 20



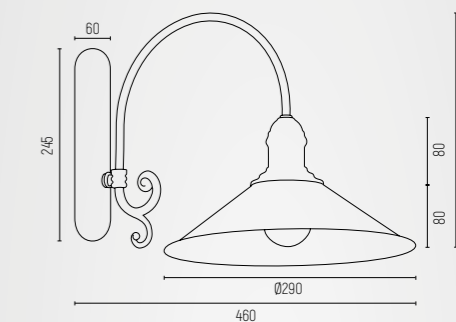

ERBA 632

ERBA 633





ERBA 630

ERBA 631

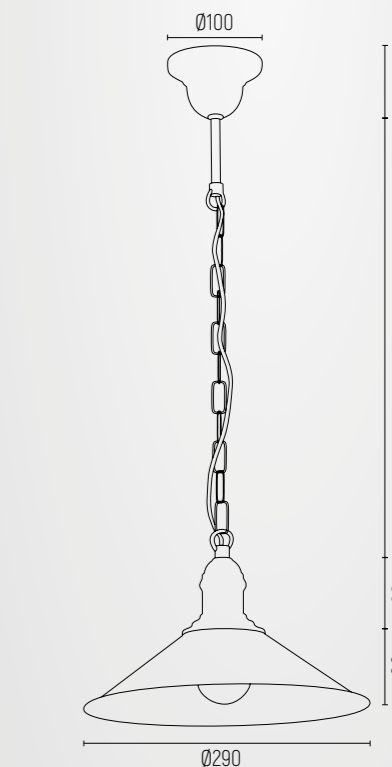
-  **632, 633** - kinkiet 1 pt.
-  320 wys. | 290 szer. | 460 gł.
-  0,8



-  **630, 631** - lampa wisząca 1 pt.
-  1150 (łańcuch 1000) wys. | 290 szer. | 290 gł.
-  0,75



ERBA BIS

- 3285, 3286 - czarna struktura
- 3296, 3297 - biały struktura
- stal lakierowana, szkło
- E27 (nie zawiera źródła światła) / 230V | 1 x 15W (max)
- IP 44

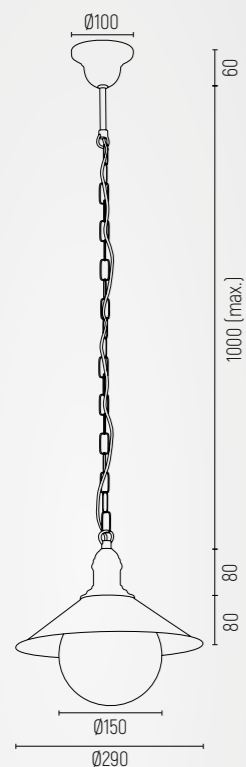

- 3285, 3296 - lampa wisząca 1 pt.
- 1260 [łańcuch 1000] wys. | 290 szer. | 290 gł.
- 1,23
- lampy ogrodowe

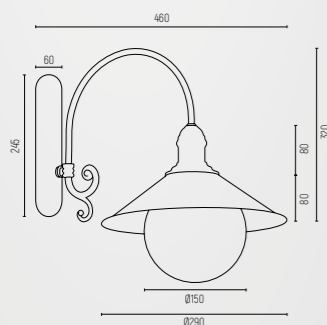

- 3286, 3297 - kinkiet 1 pt.
- 470 wys. | 290 szer. | 460 gł.
- 1,37
- lampy ogrodowe

ERBA BIS 3285



ERBA BIS 3296



ERBA BIS 3286



ERBA BIS 3297



ERBA BIS 3284



ERBA BIS 3295

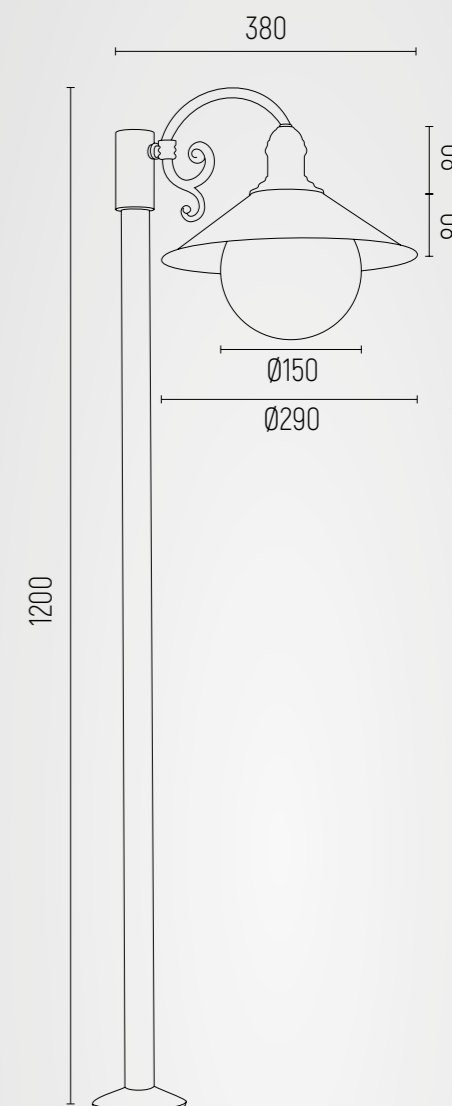

ERBA BIS

- 3284 - czarna struktura
- 3295 - biały struktura
- lampa stojąca 1 pt.
- stal lakierowana, szkło
- E27 (nie zawiera źródła światła) / 230V | 1 x 15W (max)
- 1200 wys. | 290 szer. | 380 gł.
- 2,2
- IP44
- lampy ogrodowe

ETNA PLUS

- 8064, 8066 - biały struktura
- 8065, 8067 - czarny struktura
- stal lakierowana
- G9 (nie zawiera źródła światła) / 230V | 1 x 6W (max)
- IP 20

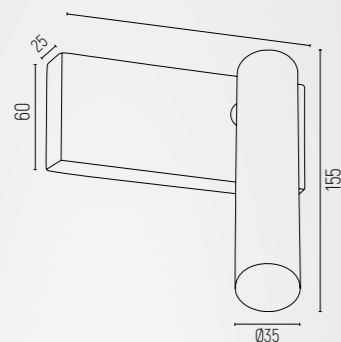

- 8064, 8065 - kinkiet 1 pt.
- 180 wys. | 140 szer. | 205 g.
- 0,4
- możliwość regulacji kąta padania światła



- 8066, 8067 - lampa wisząca 1 pt.
- 1300 (przewód 800) wys. | 80 szer. | 80 g.
- 0,5



ETNA PLUS 8064



ETNA PLUS 8065



ETNA PLUS 8066



ETNA PLUS 8067



ETNA PLUS 6178



ETNA PLUS 6179

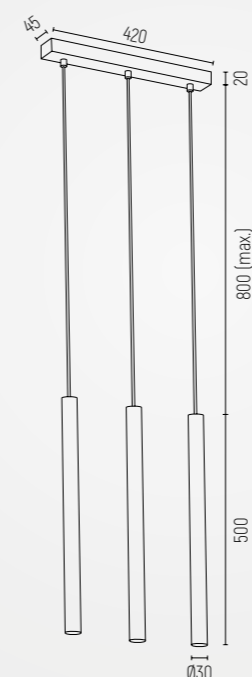

ETNA PLUS

- 6178 - biały struktura
- 6179 - czarny struktura
- lampa wisząca 3 pt.
- stal lakierowana
- G9 (nie zawiera źródła światła) / 230V | 3 x 6W (max)
- 1300 (przewód 800) wys. | 420 szer. | 40 g.
- 1,64
- IP 20



ETNA PLUS 2136



ETNA PLUS 2137



ETNA 3608



ETNA 3610



ETNA 3629



ETNA 3630

ETNA PLUS

- 2136 - biały struktura
- 2137 - czarny struktura
- ⚖️ lampa wisząca 5 pt.
- 🔧 stal lakierowana
- 💡 G9 (nie zawiera źródła światła) / 230V | 5 x 6W (max)
- 📏 1300 (przewód 800) wys. | 700 szer. | 40 g.
- ⚖️ 2,2
- 🛡️ IP 20

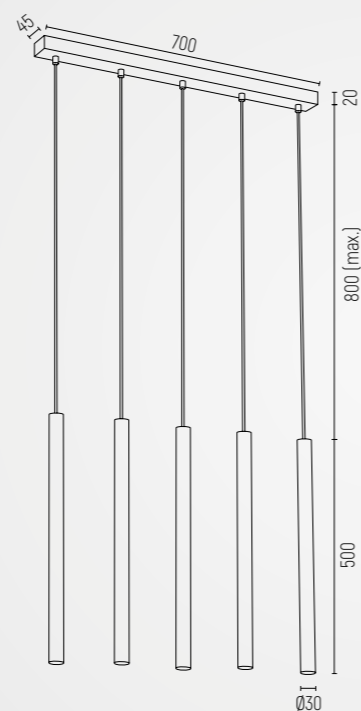

ETNA

- 3608, 3629 - biały struktura
- 3610, 3630 - czarny struktura
- 🔧 stal lakierowana
- 💡 LED (zintegrowany) / 230V / 560 lm / 3000K | 1 x 4,5W
- 🛡️ IP 20
- ⚖️ 0,4
- ⊕ możliwość regulacji kąta padania światła, możliwość zastosowania modułu LED o temperaturze barwowej 4000K - nieodpłatnie | możliwość skompletowania z kolekcją TORRE, JASPER

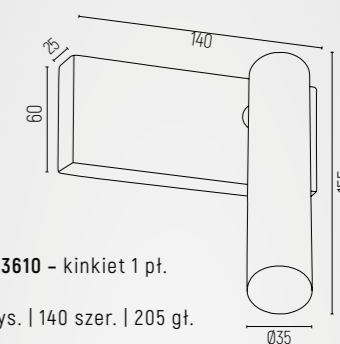

- ⚖️ 3608, 3610 - kinkiet 1 pt.
- 📏 180 wys. | 140 szer. | 205 g.
- ⚖️ 0,4

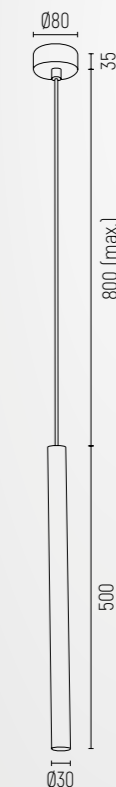

- ⚖️ 3629, 3630 - lampa wisząca 1 pt.
- 📏 1300 (przewód 800) wys. | 80 szer. | 80 g.
- ⚖️ 0,5

- ⊕ możliwość zastosowania modułu LED o temperaturze barwowej 4000K - nieodpłatnie | możliwość skompletowania z kolekcją TORRE, JASPER



ETNA 1317



ETNA 1318



ETNA 2062



ETNA 2063

ETNA

- 1317 - biały struktura
- 1318 - czarny struktura
- lampa wisząca 3 pt.
- stal lakierowana
- LED (zintegrowany) / 230V / 3x560 lm / 3000K | 3 x 4,5W
- 1300 [przewód 800] wys. | 420 szer. | 40 gł.
- 1,64
- IP 20
- możliwość zastosowania modułu LED o temperaturze barwowej 4000K - nieodpłatnie | możliwość skompletowania z kolekcją TORRE, JASPER

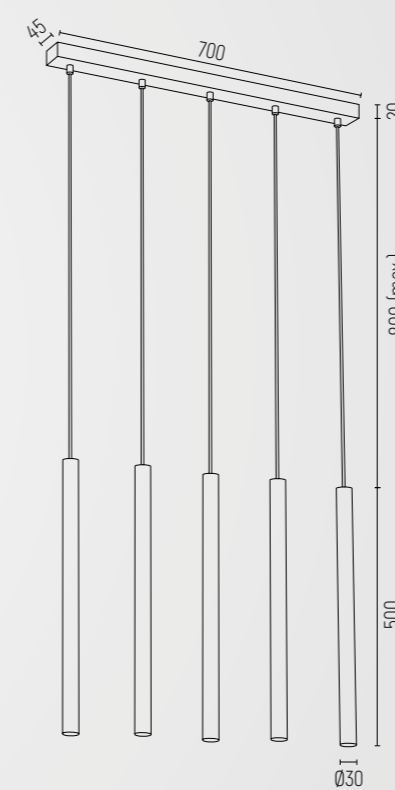
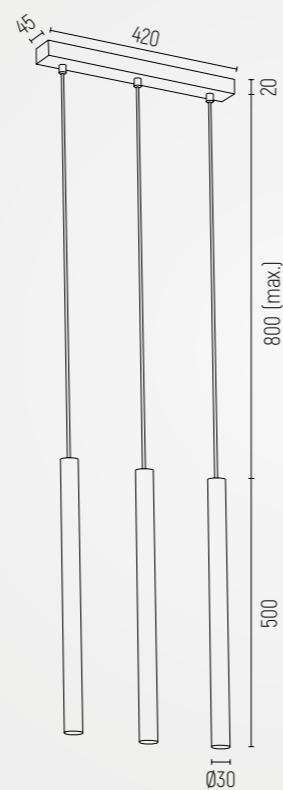

ETNA

- 2062 - biały struktura
- 2063 - czarny struktura
- lampa wisząca 5 pt.
- stal lakierowana
- LED (zintegrowany) / 230V / 5x560 lm / 3000K | 5 x 4,5W
- 1300 [przewód 800] wys. | 700 szer. | 40 gł.
- 2,2
- IP 20
- możliwość zastosowania modułu LED o temperaturze barwowej 4000K - nieodpłatnie | możliwość skompletowania z kolekcją TORRE, JASPER



EUFRAT

- 3191** - czarny struktura
- 3192** - antracyt struktura
- 3193** - biały struktura
- 3294** - chrom szczotkowany
- lampa wisząca 1 pt.
- 3191, 3192, 3193** - stal lakierowana
3294 - stal chromowana
- E27 (nie zawiera źródła światła) / 230V | 1 x 15W (max)
- 1300 (łańcuch 1000) wys. | 380 szer. | 380 gt.
- 2,16
- IP 20

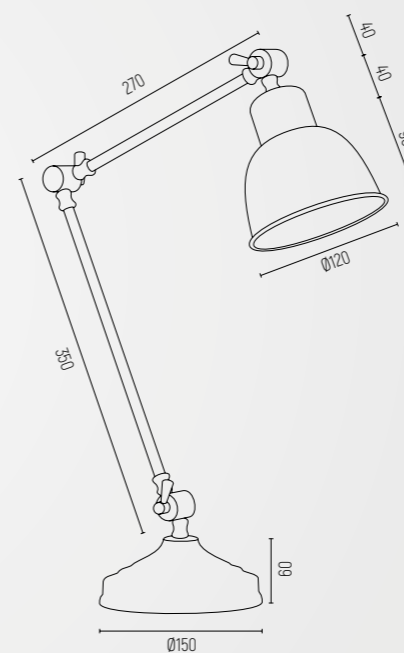
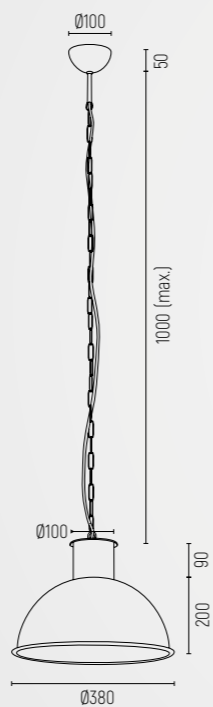

EUFRAT

- 3194** - biały struktura
- 3195** - antracyt struktura
- 3196** - chrom szczotkowany
- 3197** - czarny struktura
- lampa biurkowa 1 pt.
- 3194, 3195, 3197** - stal lakierowana
3196 - stal chromowana
- E27 (nie zawiera źródła światła) / 230V | 1 x 15W (max)
- 450 wys. | 150 szer. | 290 gt.
- 2,4
- IP 20
- możliwość regulacji



EUFRAT 3172



EUFRAT 671



EUFRAT 3182



EUFRAT 676



EUFRAT 3183



EUFRAT 677



EUFRAT 3185



EUFRAT 679

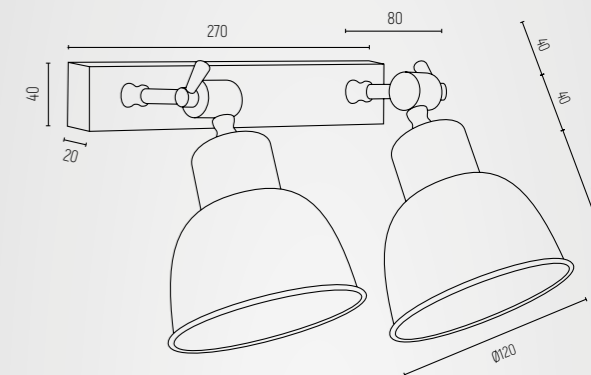
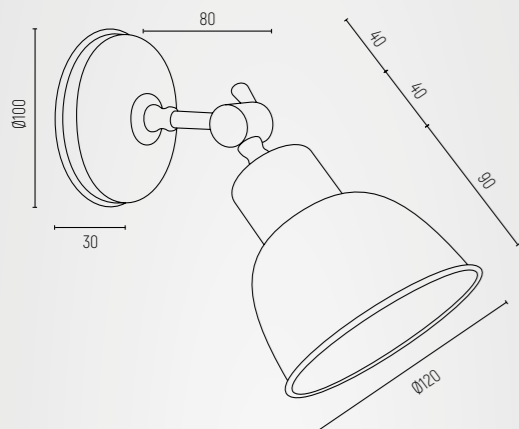





EUFRAT

-  3172 - chrom szczotkowany
-  3182 - biały struktura
-  3183 - antracyt struktura
-  3185 - czarny struktura
-  kinkiet 1 pt.
-  3182, 3183, 3185 - stal lakierowana
3172 - stal chromowana
-  E27 (nie zawiera źródła światła) / 230V | 1 x 15W (max)
-  220 (klosz 160) wys. | 120 szer. | 200 gł.
-  0,41
-  IP 20
-  możliwość regulacji, możliwość zamontowania włącznika na przyścienniku





EUFRAT

-  671 - chrom szczotkowany
-  676 - biały struktura
-  677 - antracyt struktura
-  679 - czarny struktura
-  kinkiet 2 pt.
-  676, 677, 679 - stal lakierowana
671 - stal chromowana
-  E27 (nie zawiera źródła światła) / 230V | 2 x 15W (max)
-  200 (klosz 160) wys. | 360 (klosz 120) szer. | 200 gł.
-  0,88
-  IP 20
-  możliwość regulacji

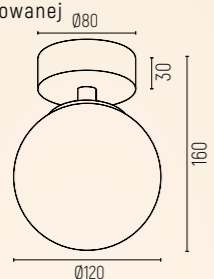



FLAVIO

-  opal mat, msiądz
-  szkło, stal msiądzowana
-  IP 44
-  + możliwość zastosowania stali lakierowanej lub chromowanej zamiast msiądzowanej

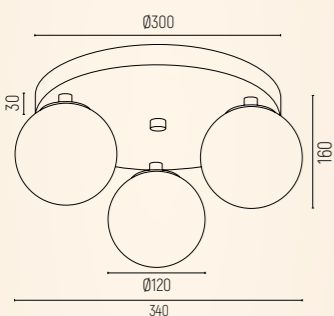





-  **4004** - plafon 1 pt.
-  E14 (nie zawiera źródła światła) / 230V | 1 x 7W (max)
-  160 wys. | 120 szer. | 120 gt.
-  1,4

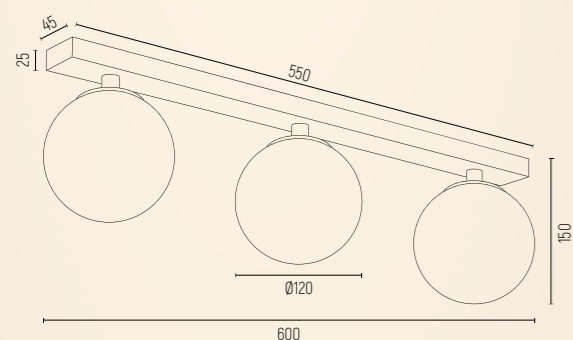

-  **1413** - plafon 3 pt. okrągła podsufitka
-  E14 (nie zawiera źródła światła) / 230V | 3 x 7W (max)
-  160 wys. | 340 szer. | 340 gt.
-  1,5



-  **1414** - plafon 3 pt. listwa
-  E14 (nie zawiera źródła światła) / 230V | 3 x 7W (max)
-  150 wys. | 600 szer. | 120 gt.
-  1,7



FLAVIO 4004



FLAVIO 1413



FLAVIO 1414







ROVETTO 4992

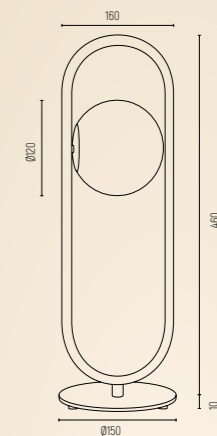





ROVETTO 7071



-  **4992** - lampa stołowa 1 pt.
-  G9 (nie zawiera źródła światła) / 230V | 1 x 6W LED (max)
-  470 wys. | 160 szer. | 150 gt.
-  1,7



-  **7071** - lampa podłogowa 2 pt.
-  E14 (nie zawiera źródła światła) / 230V | 2 x 7W (max)
-  1480 wys. | 300 szer. | 300 gt.
-  5,1

FARON

- opal mat, czarna struktura, el. mosiądzowane
- szkło, stal lakierowana, stal mosiądzowana
- G9 (nie zawiera źródła światła) / 230V | 2 x 6W (max)
- IP 20

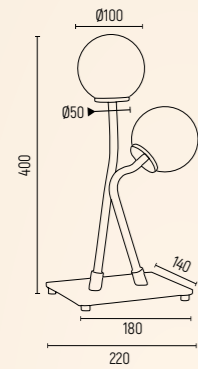

- 892 - lampa stołowa 2 pt.
- 400 wys. | 220 szer. | 140 gt.
- 2,2

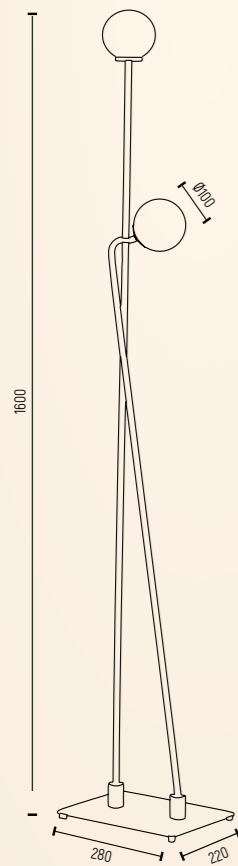

- 893 - lampa podłogowa 2 pt.
- 1600 wys. | 280 szer. | 220 gt.
- 5,1

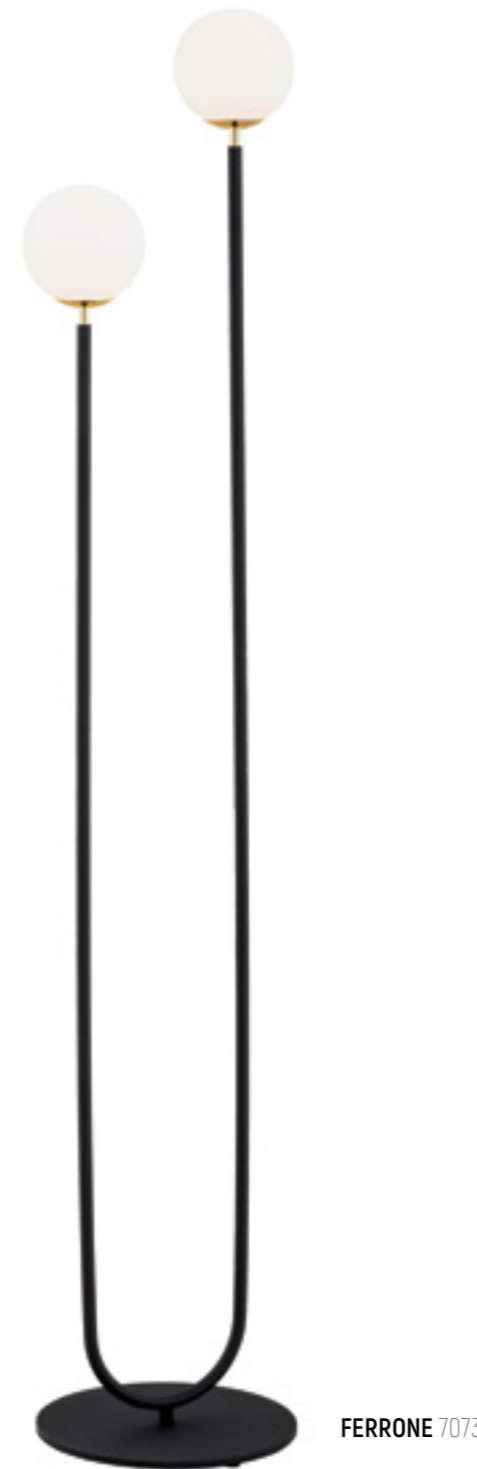

FERRONE

- opal mat, czarna struktura, el. mosiądzowane
- szkło, stal lakierowana, stal mosiądzowana
- E 14 (nie zawiera źródła światła) / 230V | 2 x 7W (max)
- IP 20

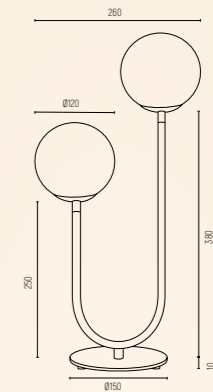

- 7072 - lampa stołowa 2 pt.
- 520 wys. | 260 szer. | 150 gt.
- 1,6

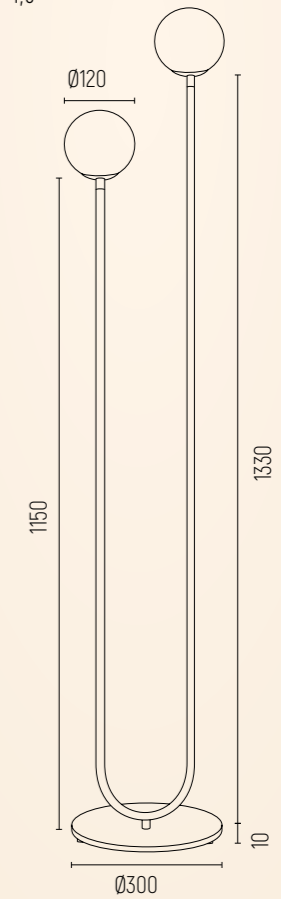

- 7073 - lampa podłogowa 2 pt.
- 1460 wys. | 300 szer. | 300 gt.
- 5,6



FOTO NEW 3354



FOTO NEW 3355



FOTO NEW 3356











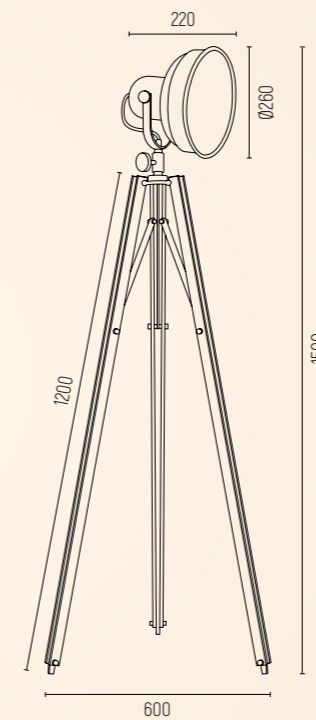





FOTO NEW

-  **3354** - naturalne drewno, klosz chromowany metal
-  **3355** - czarne drewno, klosz chromowany metal
-  **3356** - białe drewno, klosz chromowany metal
-  lampa podłogowa 1 pł.
-  drewno, stal chromowana, szkło
-  LED (zintegrowany) / 230V / 2450 lm / 3000K | 1 x 22,5W
-  1500 wys. | 600 szer. | 600 gł.
-  5
-  IP 20
-  możliwość zastosowania modułu LED o temperaturze barwowej 4000K - nieodpłatnie



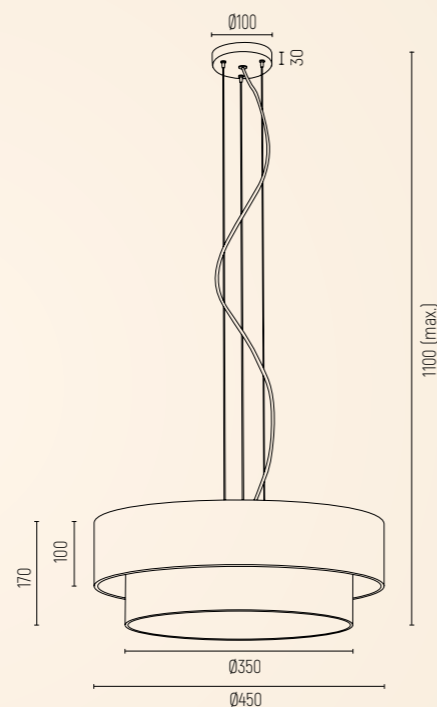

FOXY

-  1410 - biały struktura, złoty
-  1411 - czarny struktura, złoty
-  lampa wisząca 3 pt. mniejsza
-  stal lakierowana, formatka PCV
-  E27 (nie zawiera źródła światła) / 230V | 3 x 15W (max)
-  1000 (linka 800) wys. | 450 szer. | 450 gł.
-  5
-  IP 20





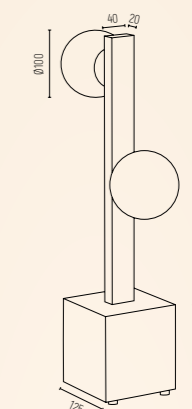

FREEMONT

-  opal mat, mosiądz szczotkowany, czarny
-  szkło, mosiądz, kamień
-  IP 20





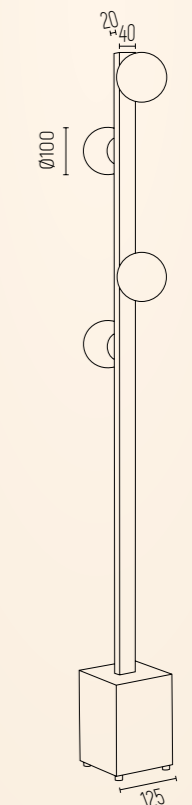

FREEMONT 1044

-  1044 - lampa stołowa 2 pt.
-  G9 (nie zawiera źródła światła) / 230V | 2 x 6W (max)
-  525 wys. | 125 szer. | 220 gł.
-  6,9











FREEMONT 1738





-  1738 - lampa podłogowa 4 pt.
-  G9 (nie zawiera źródła światła) / 230V | 4 x 6W (max)
-  1500 wys. | 125 szer. | 220 gł.
-  15,4



FREEMONT



-  opał mat, mosiądz szczotkowany
-  szkło, mosiądz
-  IP 20

-  **1767** - żyrandol 4 pt.
-  E27 (nie zawiera źródła światła) / 230V | 4 x 15W (max)
-  730 wys. | 540 szer. | 420 gł.
-  2,8
-  możliwość modyfikacji na włączanie 2+2

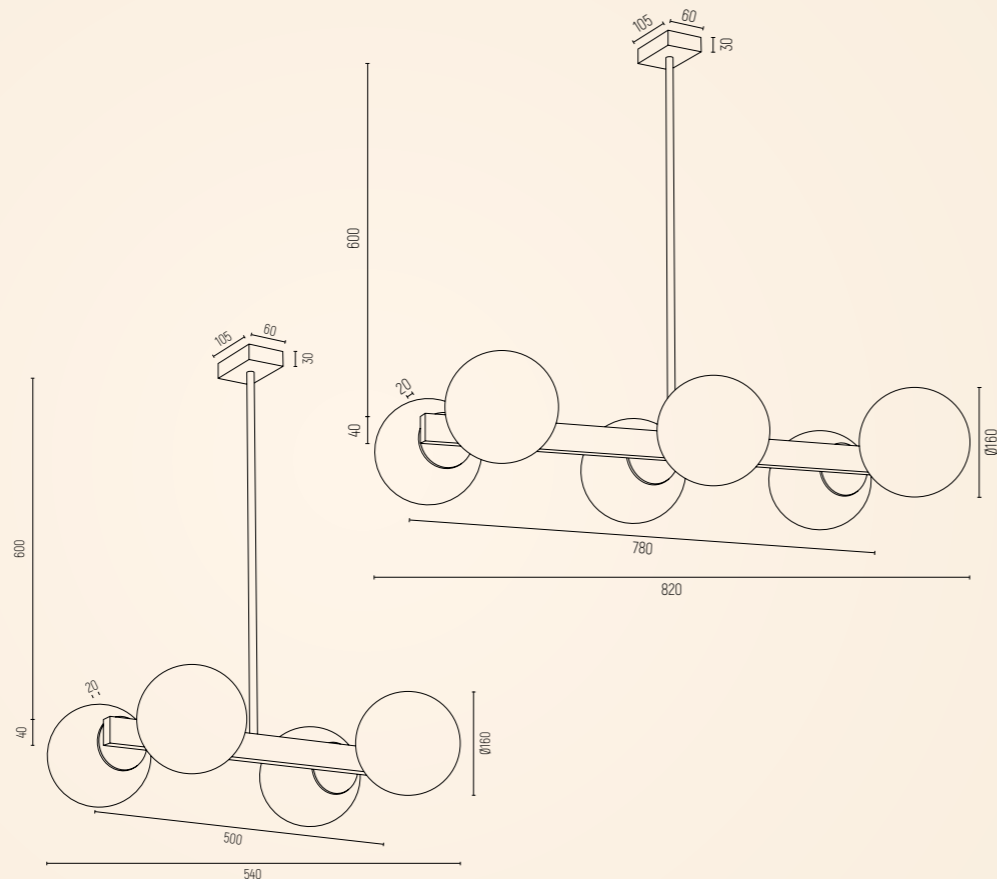



-  **2549** - żyrandol 6 pt.
-  E27 (nie zawiera źródła światła) / 230V | 6 x 15W (max)
-  730 wys. | 820 szer. | 420 gł.
-  4
-  możliwość modyfikacji na włączanie 2+4 lub 3+3



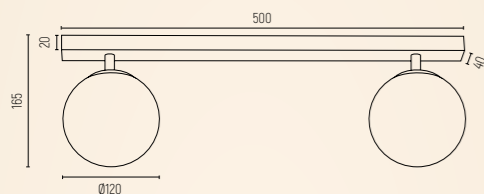



FREEMONT

-  opal mat, mosiądz szczotkowany
-  szkło, mosiądz
-  IP 20

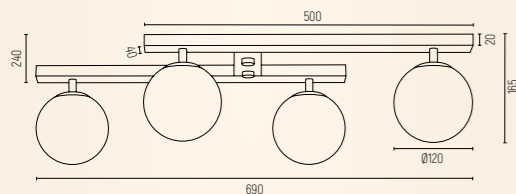





-  1045 - plafon 2 pt.
-  E14 (nie zawiera źródła światła) / 230V | 2 x 7W (max)
-  165 wys. | 500 szer. | 120 gt.
-  1

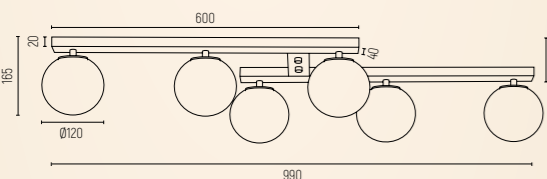

-  1742 - plafon 4 pt.
-  E14 (nie zawiera źródła światła) / 230V | 4 x 7W (max)
-  165 wys. | 690 szer. | 480 gt.
-  2



-  2544 - plafon 6 pt.
-  E14 (nie zawiera źródła światła) / 230V | 6 x 7W (max)
-  165 wys. | 990 szer. | 480 gt.
-  2,5

FREEMONT 1045



FREEMONT 1742



FREEMONT 2544







FREEMONT 4724







FREEMONT 4722

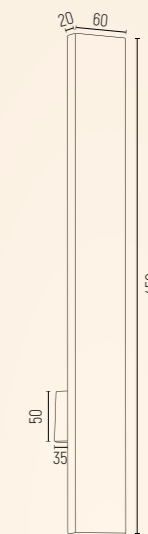



FREEMONT

-  mosiądz szczotkowany
-  mosiądz
-  IP 20
-  możliwość zastosowania modułu LED o temperaturze barwowej 4000K - nieodpłatnie



-  4724 - listwa krótsza
-  LED (zintegrowany) / 230V / 3000K | 10 W
-  450 wys. | 60 szer. | 50 gt.
-  0,45



-  4722 - listwa
-  LED (zintegrowany) / 230V / 3000K | 13,5 W
-  550 wys. | 60 szer. | 50 gt.
-  0,5



FUDŹI 3623



FUDŹI 3622



FUDŹI 3624



FUDŹI 4058



FUDŹI 3657



FUDŹI 3658











FUDŹI 3659



FUDŹI 4059

FUDŹI

-  3622 - czarny, chrom
-  3623 - czarny, czarny
-  3624 - czarny, biały
-  4058 - biały, czarny
-  lampa stołowa 1 pt.
-  abażur, szkło, stal chromowana, stal lakierowana
-  E27 (nie zawiera źródła światła) / 230V | 1 x 15W (max)
-  550 wys. | 300 szer. | 300 gł.
-  1,7
-  IP 20

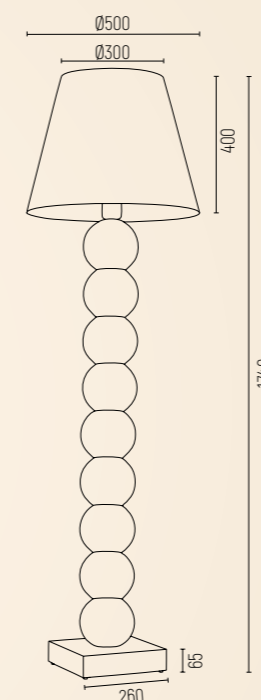
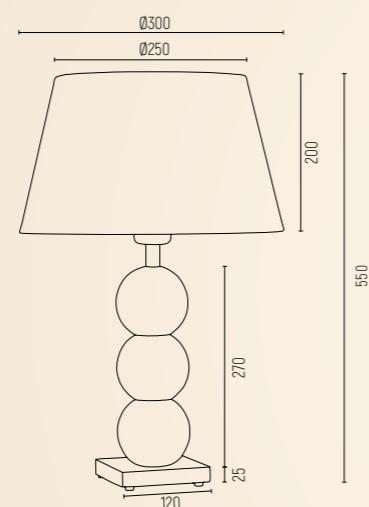







FUDŹI

-  3657 - czarny, chrom
-  3658 - czarny, biały
-  3659 - czarny, czarny
-  4059 - biały, czarny
-  lampa podłogowa 1 pt.
-  abażur, szkło, stal chromowana
-  E27 (nie zawiera źródła światła) / 230V | 1 x 15W (max)
-  1740 wys. | 500 szer. | 500 gł.
-  7,4
-  IP 20









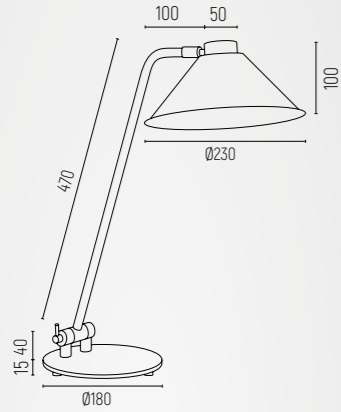

GABIAN

-  4996, 4997 - biały struktura
-  4998, 4999 - czarny struktura
-  stal lakierowana
-  E27 (nie zawiera źródła światła) / 230V | 1 x 15W (max)
-  IP 20
-  możliwość regulacji

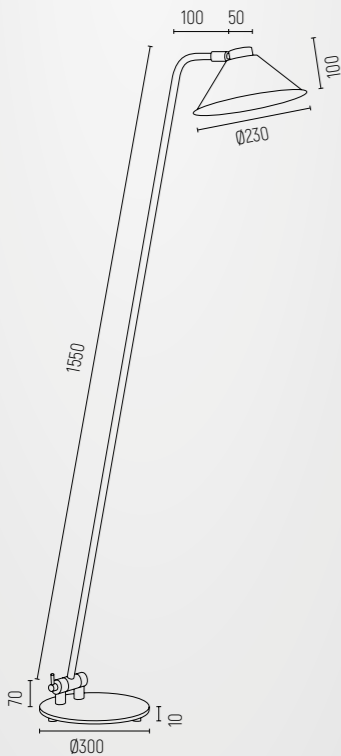

-  4996, 4998 - lampa biurkowa 1 pt.
-  550 wys. | 230 szer. | 350 gt.
-  2,6



-  4997, 4999 - lampa podłogowa 1 pt.
-  1680 wys. | 300 szer. | 400 gt.
-  5,3



GABIAN 4996



GABIAN 4998



GABIAN 4997



GABIAN 4999



GABIAN 7074



GABIAN 7075

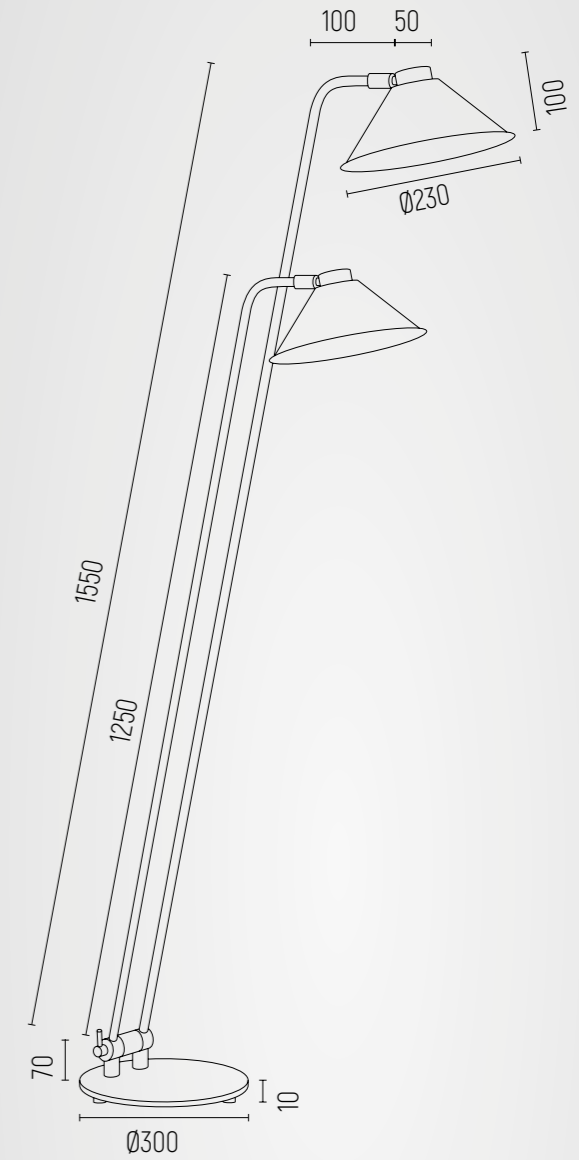

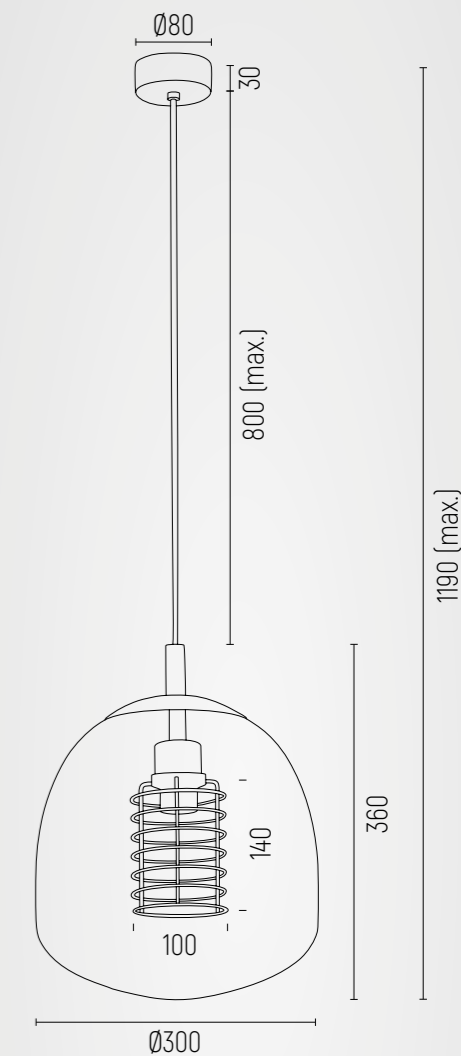

GABIAN

-  7074 - biały struktura
-  7075 - czarny struktura
-  lampa podłogowa 2 pt.
-  stal lakierowana
-  E27 (nie zawiera źródła światła) / 230V | 2 x 15W (max)
-  1680 wys. | 300 szer. | 400 gt.
-  6,5
-  IP 20
-  możliwość regulacji



GLEN

-  **4739** - transparentny, el. mosiądzowane
-  **4677** - dymny, el. mosiądzowane
-  lampa wisząca 1 pt.
-  szkło, stal mosiądzowana
-  E27 (nie zawiera źródła światła) / 230V | 1 x 15W (max)
-  przewód max. 800, całość 1190 wys. | 300 szer. | 300 g.
-  2,2
-  IP 20

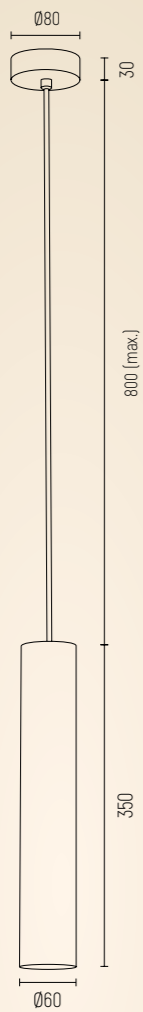

GOMERA PLUS GOMERA

-  4755 - msiądz, czarny struktura
-  4756 - czarny struktura
-  3628 - chrom
-  4057 - msiądz
-  lampa wisząca 1 pt.
-  4755 - stal msiądzowana, stal lakierowana
-  4756 - stal lakierowana
-  3628 - stal chromowana
-  4057 - stal msiądzowana
-  GU10 (nie zawiera źródła światła) / 230V | 1 x 5W (max)
-  przewód max. 800, całość 1180 wys. | 80 szer. | 80 g.
-  1,02
-  IP 20

GOMERA PLUS 4755



GOMERA 3628



GOMERA PLUS 4756



GOMERA 4057



GOMERA PLUS 6113



GOMERA PLUS 6112



GOMERA 1316



GOMERA 1443

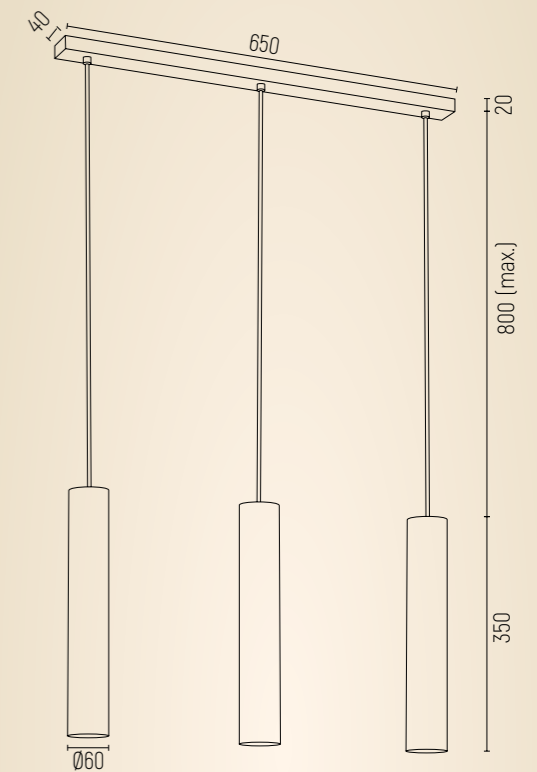

GOMERA PLUS GOMERA

-  6113 - msiądz, czarny struktura
-  6112 - czarny struktura
-  1316 - chrom
-  1443 - msiądz
-  lampa wisząca 3 pt.
-  6113 - stal msiądzowana, stal lakierowana
-  6112 - stal lakierowana
-  1316 - stal chromowana
-  1443 - stal msiądzowana
-  GU10 (nie zawiera źródła światła) / 230V | 3 x 5W (max)
-  przewód max. 800, całość 1170. | 650 szer. | 60 g.
-  3,31
-  IP 20
-  możliwość modyfikacji na włączenie 1+2

HERMAN

- złoty, czarny struktura
- abazur, stal lakierowana
- E27 (nie zawiera źródła światła) / 230V | 1 x 15W (max)
- IP 20

- 4279, 4300 - kinkiet 1 pt.
- 4279 - max. 250 wys. | 160 szer. | 320 gł.
- 4300 - max. 210 wys. | 105 szer. | max.250 gł.

- 4279 - 0,7
- 4300 - 0,4
- możliwość regulacji, możliwość zamontowania włącznika na przycienniku

- 4280 - plafon 1 pt. mniejszy
- 165 wys. | 105 szer. | 105 gł.
- 0,4

- 4247 - plafon 1 pt. większy
- 190 wys. | 160 szer. | 160 gł.
- 0,6

- 4248 - lampa wisząca 1 pt.
- przewód max. 800, całość 1100 wys. | 160 szer. | 160 gł.
- 0,7

- 1491 - plafon 3 pt.
- E27 (nie zawiera źródła światła) / 230V | 3 x 15W (max)
- 190 wys. | 880 szer. | 105 gł.
- 2,4
- możliwość regulacji

- 1490 - lampa wisząca 3 pt. listwa
- E27 (nie zawiera źródła światła) / 230V | 3 x 15W (max)
- przewód max. 800, całość 1100 wys. | 850 szer. | 160 gł.
- 2,4

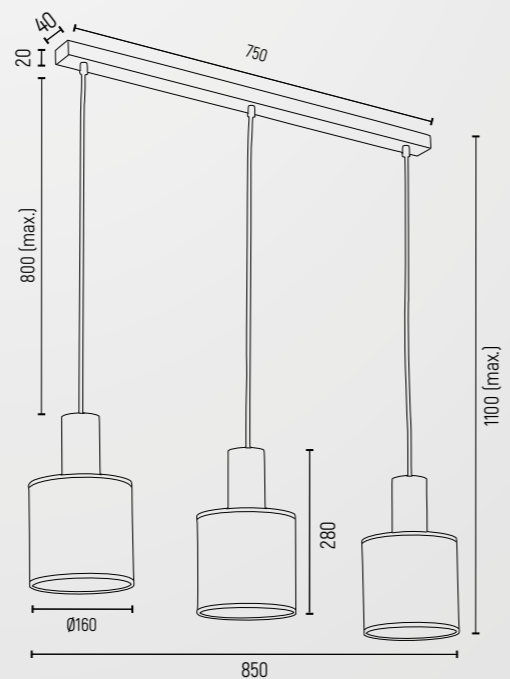
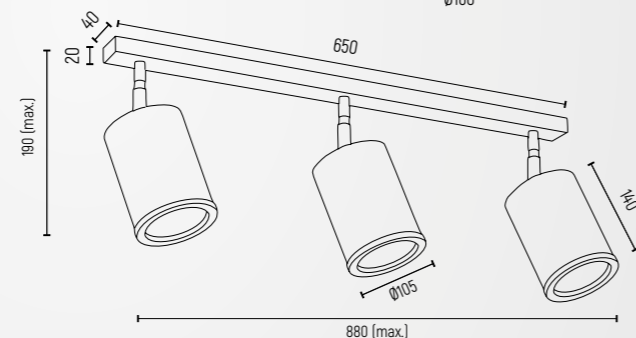
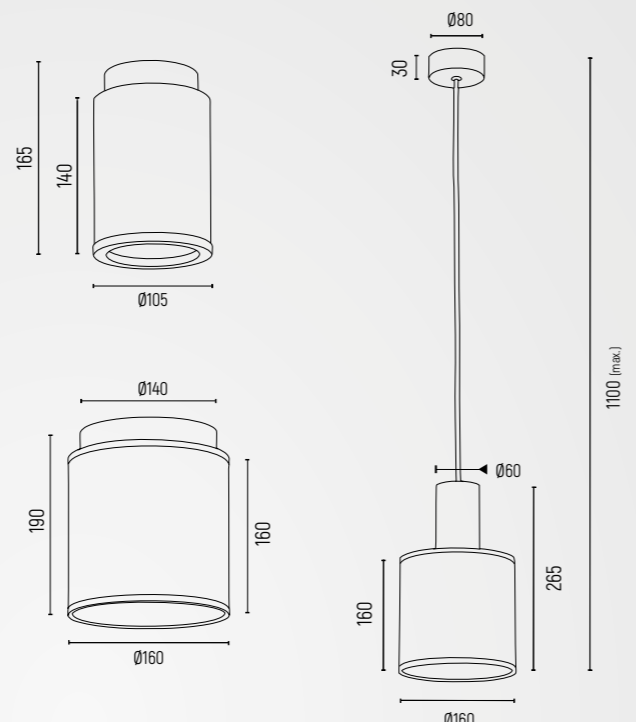
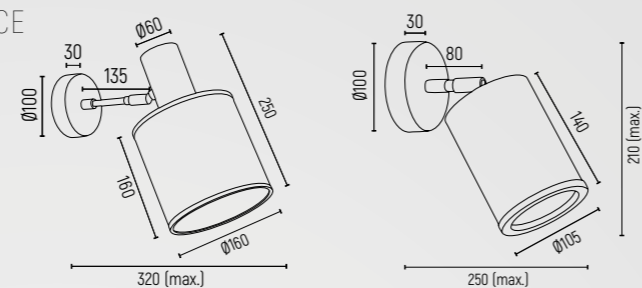

HERMAN 4279



HERMAN 4300



HERMAN 4280



HERMAN 4247



HERMAN 1491



HERMAN 4248



HERMAN 1490

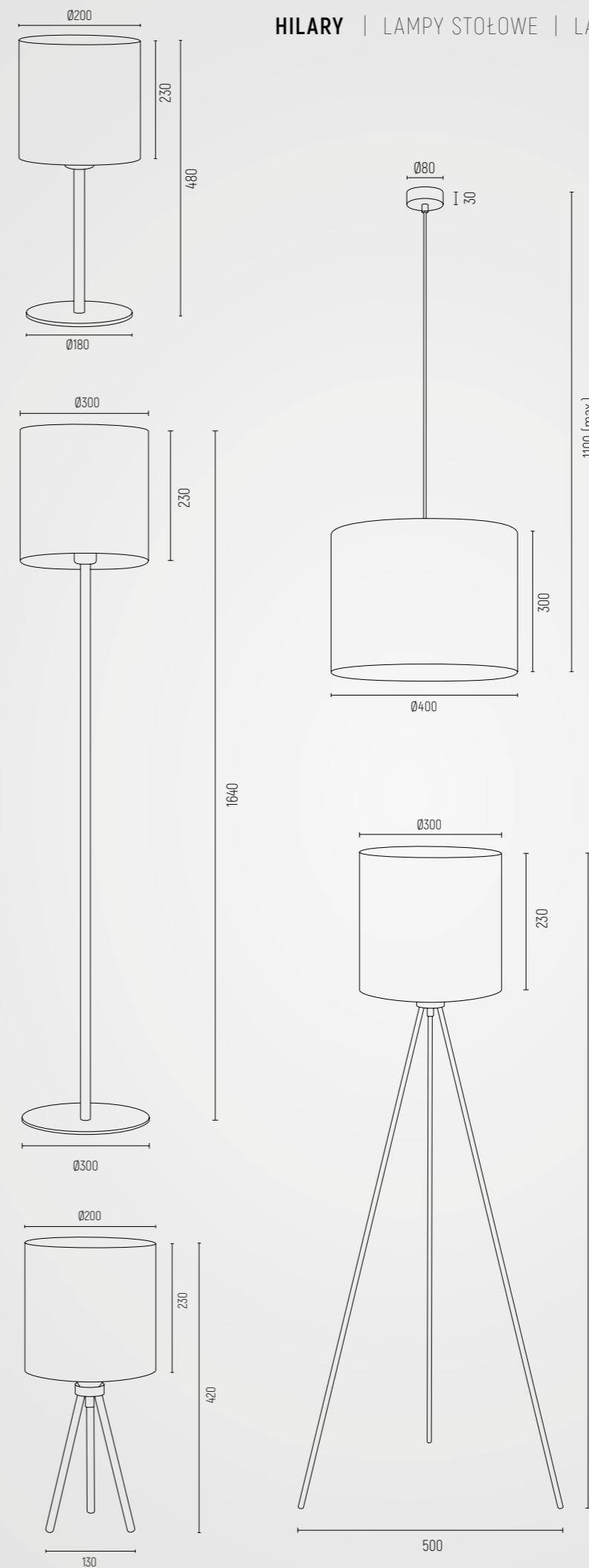

HILARY

- biały, czarny struktura
- abażur, stal lakierowana
- E27 (nie zawiera źródła światła) / 230V | 1 x 15W (max)
- IP 20

- 4081** - lampa stołowa 1 pt.
- 480 wys. | 200 szer. | 200 g.
- 1,6

- 4082** - lampa podłogowa 1 pt.
- 1640 wys. | 300 szer. | 300 g.
- 4,8







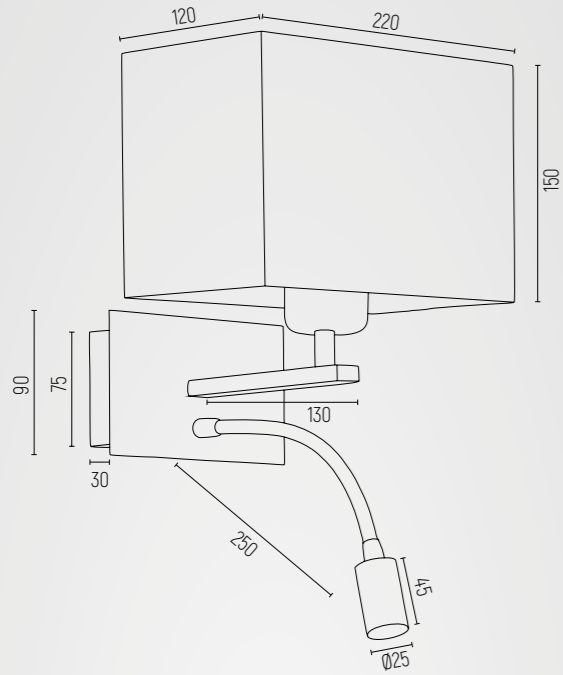

- 4083** - lampa stołowa 1 pt.
- 420 wys. | 200 szer. | 200 g.
- 1,3
- trójnóg

- 4084** - lampa podłogowa 1 pt.
- 1430 wys. | 500 szer. | 500 g.
- 4,2
- trójnóg

- 4085** - lampa wisząca 1 pt.
- 1100 (przewód 800) wys. | 400 szer. | 400 g.
- 0,7



HILARY

-  **867** - biały, chrom
-  **868** - biały, czarny mat
-  kinkiet 2 pt.
-  **867** - abażur, stal chromowana
868 - abażur, stal lakierowana
-  E27 (nie zawiera źródła światła) / 230V + LED (zintegrowany) / 230V / 560 lm / 3000K | 1 x 15W (max) + 1 x 4,5W
-  max 480 wys. | 200 szer. | 220 g.
-  0,6
-  IP 20
-  możliwość zastosowania modułu LED o temperaturze barwowej 4000K - nieodpłatnie

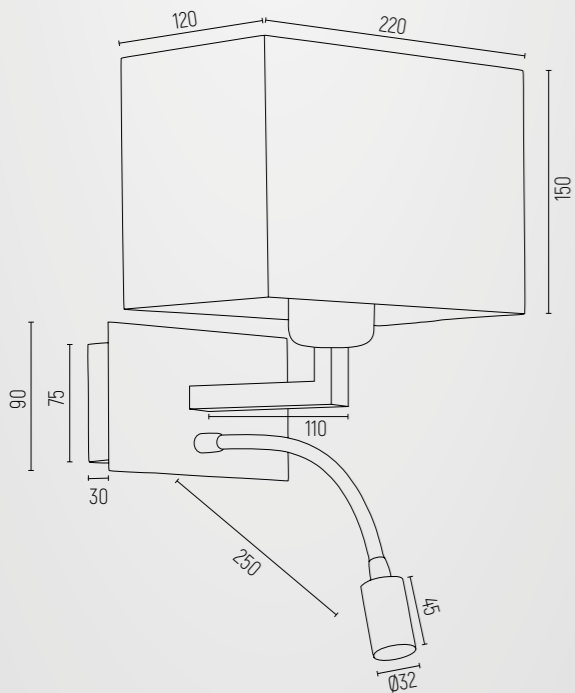

HILARY 867



HILARY 868

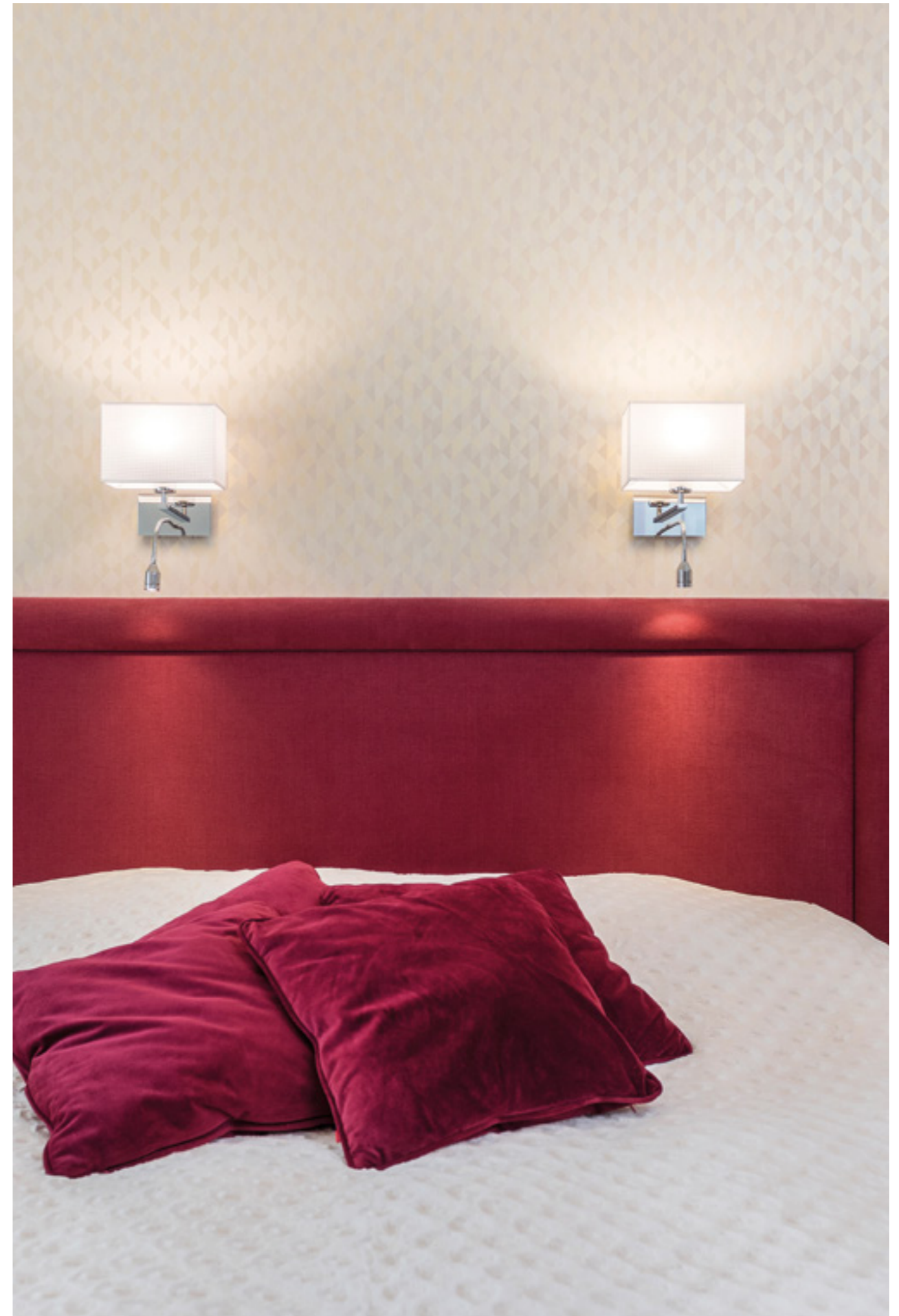



IRUN 4266



IRUN 4267



IRUN 4273



IRUN 4277



IRUN 4268



IRUN 4269













IRUN 4272









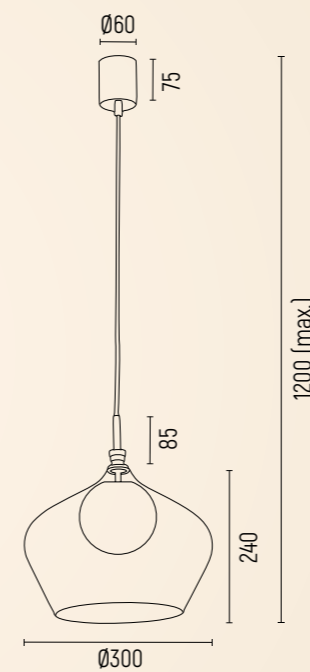
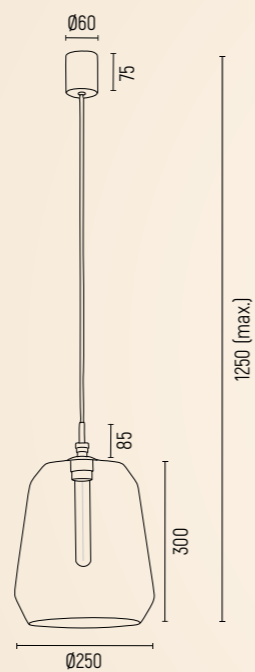





IRUN 4278

IRUN

-  4266 - transparentny, el. mosiądzowane
-  4267 - dymny, el. mosiądzowane
-  4273 - opal, el. mosiądzowane
-  4277 - czarny połysk, el. mosiądzowane
-  lampa wisząca 1 pt.
-  szkło, stal mosiądzowana
-  E27 (nie zawiera źródła światła) / 230V | 1 x 15W (max)
-  przewód max.800, całość 1250 wys. | 250 szer. | 250 gł.
-  1,25
-  IP 20
-  możliwość zastosowania el. chromowanych zamiast el. mosiądzowanych



IRUN

-  4268 - transparentny, opal mat, el. mosiądzowane
-  4269 - dymny, opal mat, el. mosiądzowane
-  4272 - opal, el. mosiądzowane
-  4278 - czarny połysk, el. mosiądzowane
-  lampa wisząca 1 pt.
-  szkło, stal mosiądzowana
-  4268, 4269 - E14 (nie zawiera źródła światła) / 230V | 1 x 7W (max)
-  4272, 4278 - E27 (nie zawiera źródła światła) / 230V | 1 x 15W (max)
-  przewód max.800, całość 1200 wys. | 300 szer. | 300 gł.
-  4268, 4269 - 1,4
-  4272, 4278 - 1,2
-  IP 20
-  możliwość zastosowania el. chromowanych zamiast el. mosiądzowanych

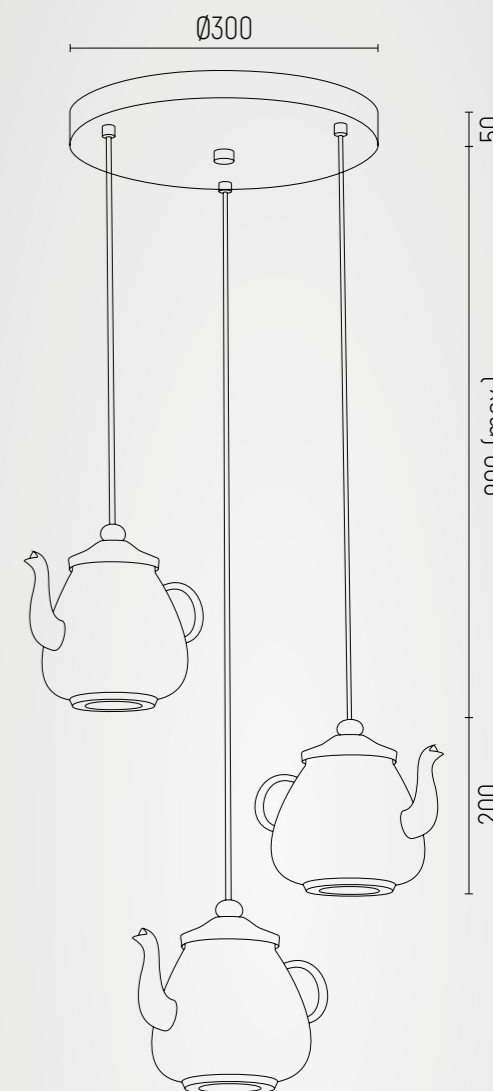

JAMAJKA

- 3650 - biały struktura
- 3651 - żółty mat
- 3652 - miętowy struktura
- 3653 - antracyt struktura
- lampa wisząca 1 pt.
- stal lakierowana
- GU10 (nie zawiera źródła światła) / 230V | 1 x 5W (max)
- 1050 (przewód 800) wys. | 200 szer. | 150 gł.
- 0,7
- IP 20

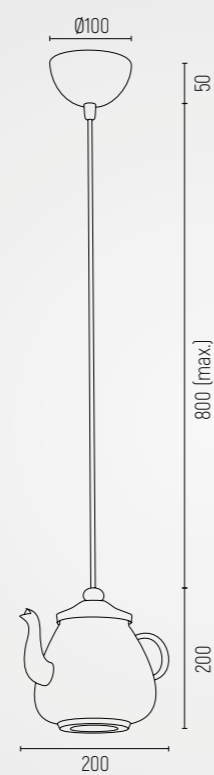

JAMAJKA

- 1326 - dowolna kolorystyka
- lampa wisząca 3 pt.
- stal lakierowana, stal chromowana
- GU10 (nie zawiera źródła światła) / 230V | 3 x 5W (max)
- 1050 (najdłuższy przewód 800) wys. | 500 szer. | 500 gł.
- 2
- IP 20
- możliwość modyfikacji na włączanie 1+2

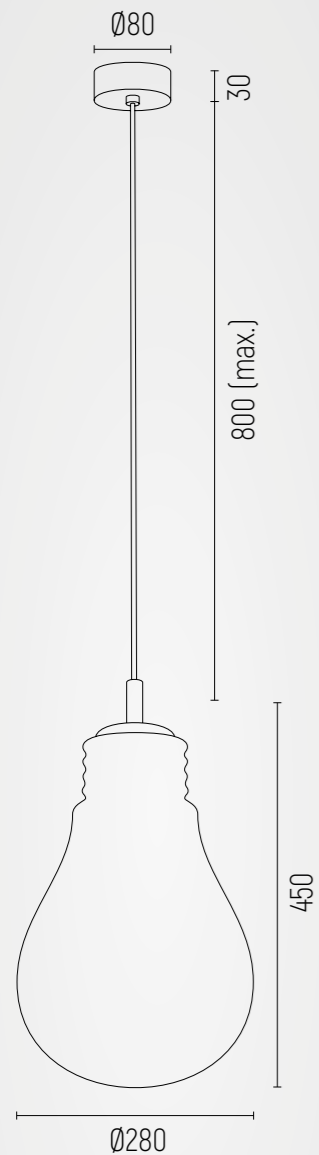

JESSE

-  **4879** - opal, mosiądz
-  lampa wisząca 1 pt.
-  szkło, stal mosiądzowana
-  E27 (nie zawiera źródła światła) / 230V | 1 x 15W (max)
-  1280 wys. | 280 szer. | 280 gt.
-  1,1
-  IP 20







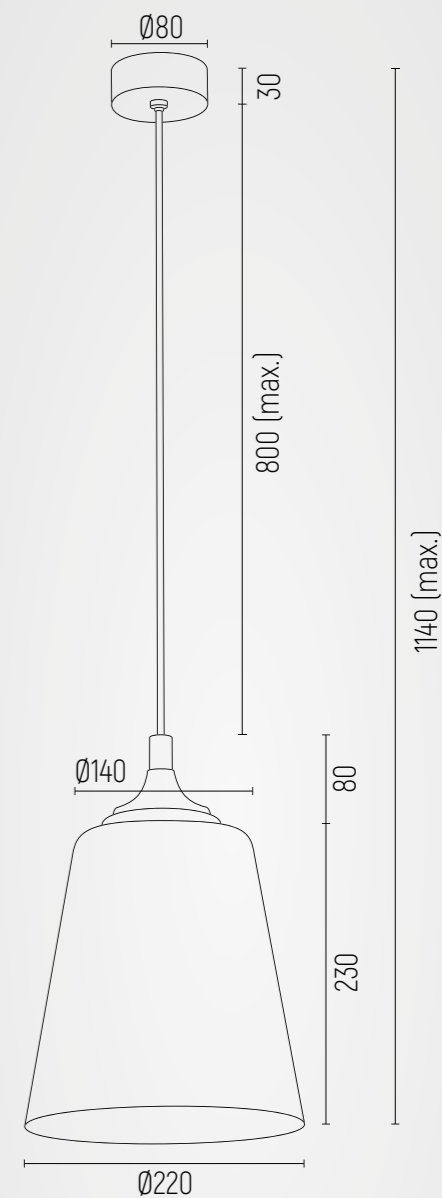

JESSE 4879



JACKSON 4698



JACKSON

-  **4698** - opal mat, el. mosiądzowane
-  lampa wisząca 1 pt.
-  szkło, stal mosiądzowana
-  E27 (nie zawiera źródła światła) / 230V | 1 x 15W (max)
-  przewód max. 800, całość 1140 wys. | 220 szer. | 220 gt.
-  0,9
-  IP 20

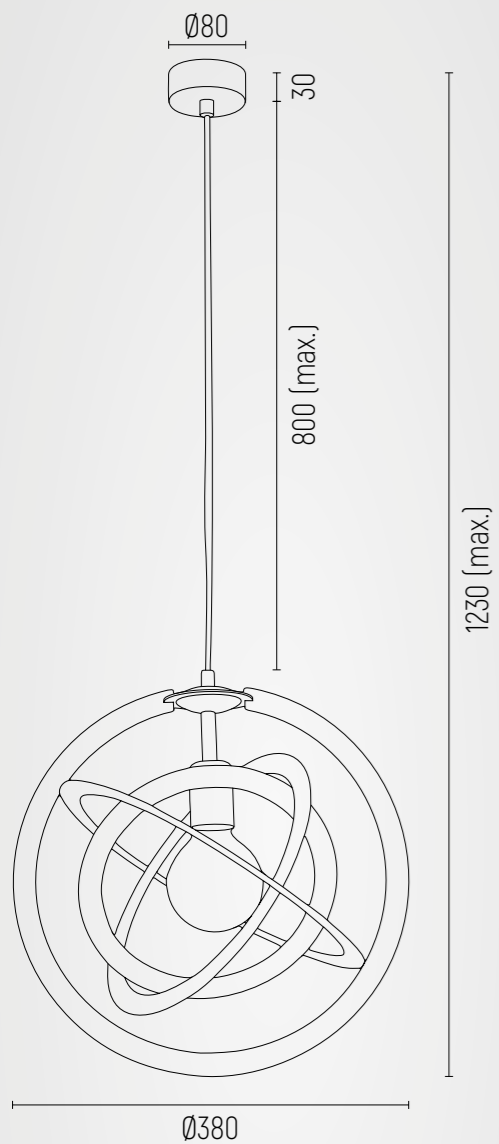

KOPERNIK

- 4026** - biały struktura
- 4027** - czarny struktura, el. mosiądzowane
- lampa wisząca 1 pt. większa
- 4026** - stal lakierowana
4027 - stal lakierowana, stal mosiądzowana
- E27 (nie zawiera źródła światła) / 230V | 1 x 15W (max)
- 1200 (przewód 800) wys. | 380 szer. | 340 gt.
- 1,7
- IP 20

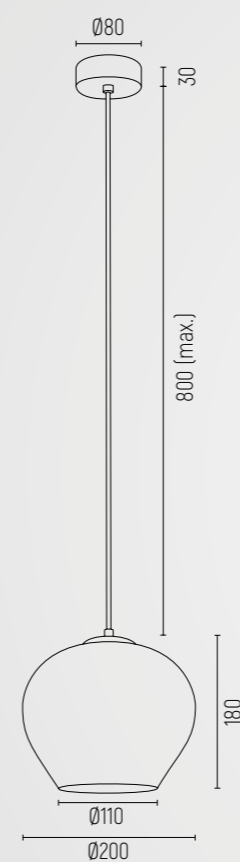

KALIMERA

- 4040, 4042** - opal mat, chrom
- 4041, 4043** - transparentny, czarny mat
- 4040, 4042** - szkło, stal chromowana
4041, 4043 - szkło, stal lakierowana
- E27 (nie zawiera źródła światła) / 230V | 1 x 15W (max)
- IP 20
- możliwość zastosowania el. mosiądzowanych zamiast el. lakierowanych / chromowanych
- 4040, 4041** - lampa wisząca 1 pt. mniejsza
- 1000 (przewód 800) wys. | 200 szer. | 200 gt.
- 0,8
- 4042, 4043** - lampa wisząca 1 pt. większa
- 1100 (przewód 800) wys. | 240 szer. | 240 gt.
- 0,9

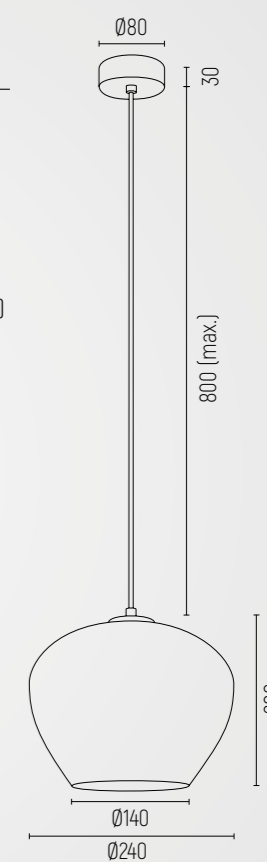

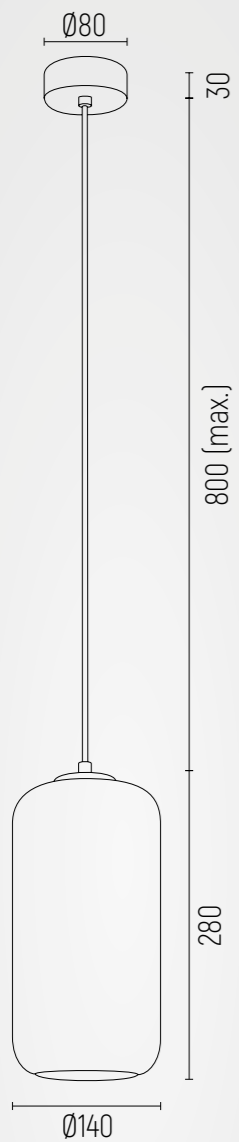

KALIMERA 4038



KALIMERA 4039



KALIMERA 1430









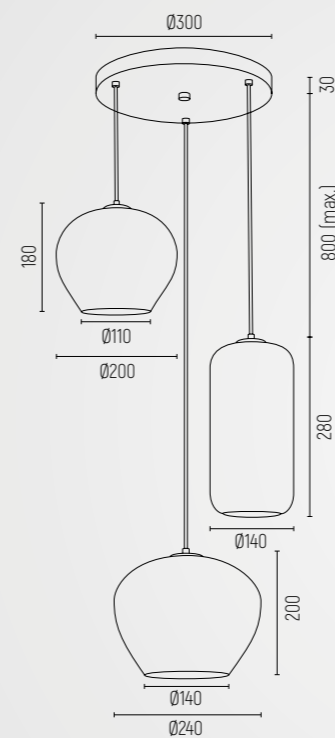



KALIMERA 1431

KALIMERA

-  4038 - opal mat, chrom
-  4039 - transparentny, czarny mat
-  lampa wisząca 1 pt.
-  4038 - szkło, stal chromowana
-  4039 - szkło, stal lakierowana
-  E27 (nie zawiera źródła światła) / 230V | 1 x 15W (max)
-  1100 (przewód 800) wys. | 140 szer. | 140 g.
-  0,7
-  IP 20
-  możliwość zastosowania el. mosiądzowanych zamiast el. lakierowanych / chromowanych



KALIMERA

-  1430 - opal mat, chrom
-  1431 - transparentny, czarny mat
-  lampa wisząca 3 pt.
-  1430 - szkło, stal chromowana
-  1431 - szkło, stal lakierowana
-  E27 (nie zawiera źródła światła) / 230V | 3 x 15W (max)
-  1200 (przewód 800) | 400 szer. | 400 g.
-  2,5
-  IP 20
-  możliwość modyfikacji na włączanie 1+2 | możliwość zastosowania el. mosiądzowanych zamiast el. lakierowanych / chromowanych



KARIN 4340









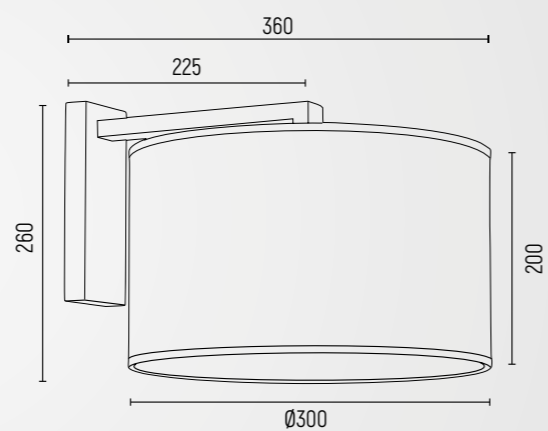



KARIN 4295



KARIN 4294



KARIN

-  4295 - złoty, czarny struktura
-  4340 - czarny ze złotym środkiem, czarny struktura
-  4294 - biały, biały struktura
-  kinkiet 1 pt.
-  abażur, stal lakierowana
-  E27 (nie zawiera źródła światła) / 230V | 1 x 15W (max)
-  260 wys. | 300 szer. | 360 gł.
-  0,75
-  IP 20
-  możliwość zamontowania włącznika na przyścienniku



KARIN 4297





KARIN 4342

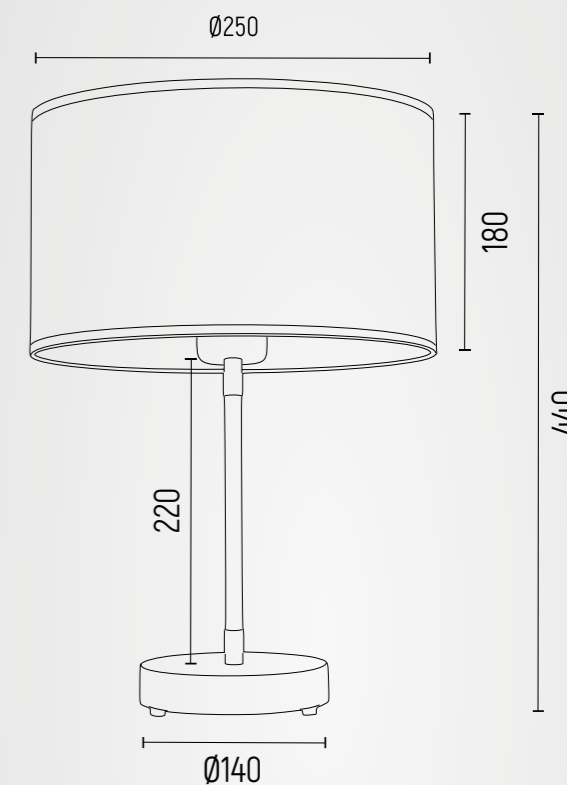

KARIN 4301











KARIN

-  4297 - złoty, czarny struktura
-  4342 - czarny ze złotym środkiem, czarny struktura
-  4301 - biały, mosiądz
-  lampa stołowa 1 pt.
-  4297, 4342 - abażur, stal lakierowana
-  4301 - abażur, stal mosiądzowana
-  E27 (nie zawiera źródła światła) / 230V | 1 x 15W (max)
-  440 wys. | 250 szer. | 250 gł.
-  1,35
-  IP 20







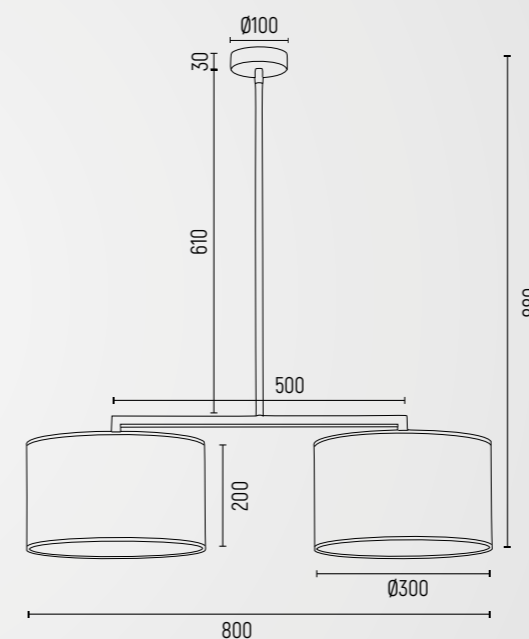
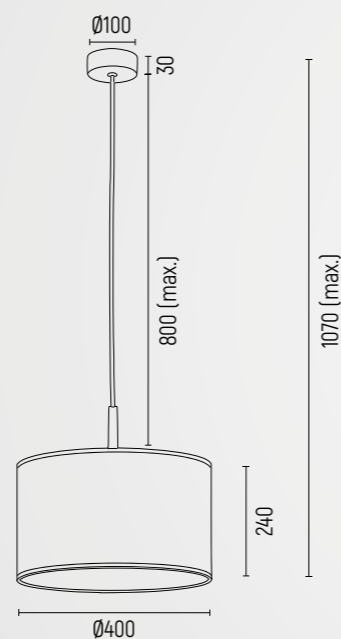





KARIN

-  4291 - złoty, czarna struktura
-  4341 - czarny ze złotym środkiem, czarna struktura
-  4343 - biały, biała struktura
-  lampa wisząca 1 pt.
-  abażur, stal lakierowana
-  E27 (nie zawiera źródła światła) / 230V | 1 x 15W (max)
-  przewód max. 800, całość max. 1070 wys. | 400 szer. | 400 g.
-  0,75
-  IP 20



KARIN

-  898 - złoty, czarna struktura
-  899 - czarny ze złotym środkiem, czarna struktura
-  900 - biały, biała struktura
-  lampa wisząca 2 pt.
-  abażur, stal lakierowana, el. mosiężowane
-  E27 (nie zawiera źródła światła) / 230V | 2 x 15W (max)
-  880 wys. | 800 szer. | 300 g.
-  1,6
-  IP 20
-  możliwość modyfikacji na włączanie 1+1

KASER

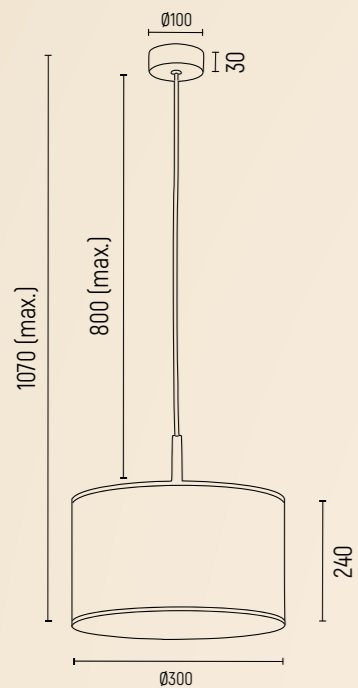

⚡ E27 (nie zawiera źródła światła) / 230V | 1 x 15W (max)

🛡️ IP 20

🌀 4344 - biało szary ze złotym dekorem, el. mosiądżowane

🏠 lampa wisząca 1 pt. mniejsza

📄 abażur, stal mosiądżowana

📏 przewód max. 800, całość 1070 wys. | 300 szer. | 300 g.

⚖️ 0,7

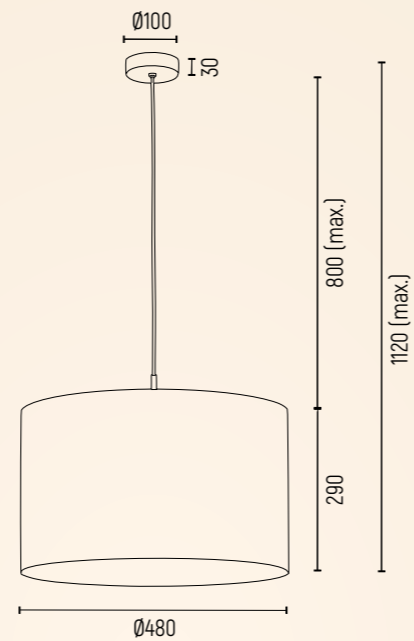

🌀 4285 - biało szary ze złotym dekorem, el. mosiądżowane

🏠 lampa wisząca 1 pt. większa

📄 abażur, stal mosiądżowana

📏 przewód max. 800, całość 1120 wys. | 480 szer. | 480 g.

⚖️ 0,9

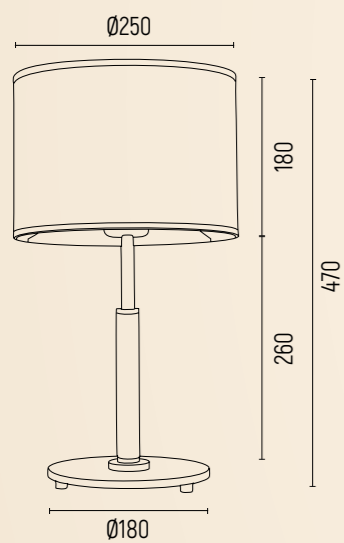

🌀 4286 - biało szary ze złotym dekorem, biały struktura, el. mosiądżowane

🏠 lampa stołowa 1 pt.

📄 abażur, stal lakierowana, stal mosiądżowana

📏 470 wys. | 250 szer. | 250 g.

⚖️ 2,3

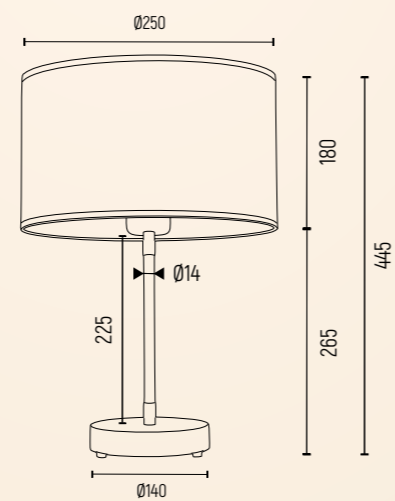

🌀 4298 - biało szary ze złotym dekorem, mosiądz

🏠 lampa stołowa 1 pt.

📄 abażur, stal mosiądżowana

📏 450 wys. | 250 szer. | 250 g.

⚖️ 1,35

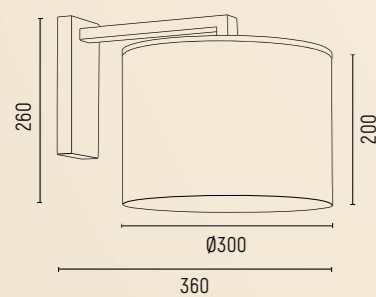

🌀 4293 - biało szary ze złotym dekorem, biały struktura

🏠 kinkiet 1 pt.

📄 abażur, stal lakierowana

📏 260 wys. | 300 szer. | 360 g.

⚖️ 0,75

⊕ możliwość zamontowania włącznika na przyścienniku



KASER 4344



KASER 4286



KASER 4298



KASER 4285



KASER 4293



KASER 901



KASER 4287

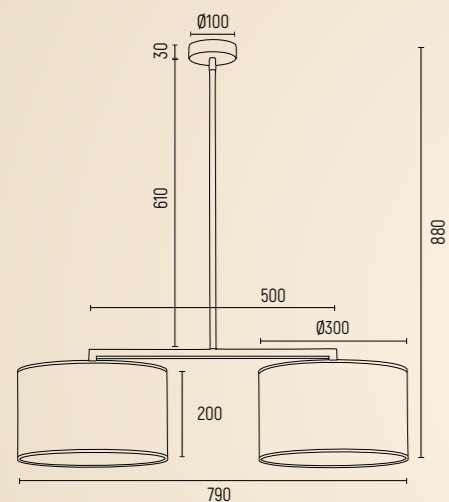

KASER

- biało szary ze złotym dekokrem, biały struktura, el. mosiądzowane
- abażur, stal lakierowana, stal mosiądzowana
- IP 20

- 901 - lampa wisząca 2 pt.
- E27 (nie zawiera źródła światła) / 230V | 2 x 15W (max)
- 880 wys. | 790 szer. | 300 gt.
- 1,6
- możliwość modyfikacji na włączanie 1+1

- 4287 - lampa podłogowa 1 pt.
- E27 (nie zawiera źródła światła) / 230V | 1 x 15W (max)
- 1560 wys. | 400 szer. | 400 gt.
- 5,9



KOS PLUS 4901



KOS PLUS 4902

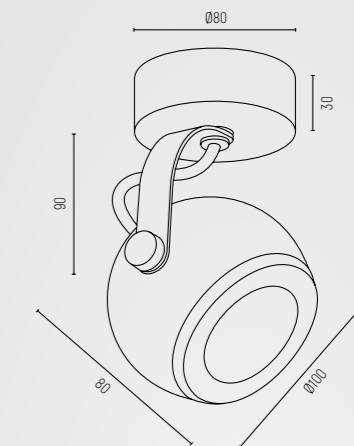

KOS PLUS

- 4901, 7038 - biały struktura, el. mosiądzowane
- 4902, 7039 - czarny struktura, el. mosiądzowane
- stal lakierowana, stal mosiądzowana
- IP 20
- możliwość regulacji

- 4901, 4902 - kinkiet 1 pt.
- GU10 (nie zawiera źródła światła) / 230V | 1 x 5W (max)
- 150 wys. | 100 szer. | 100 gt.
- 0,4

- 7038, 7039 - plafon 2 pt.
- GU10 (nie zawiera źródła światła) / 230V | 2 x 5W (max)
- 150 wys. | 340 szer. | 100 gt.
- 0,8



KOS PLUS 7038





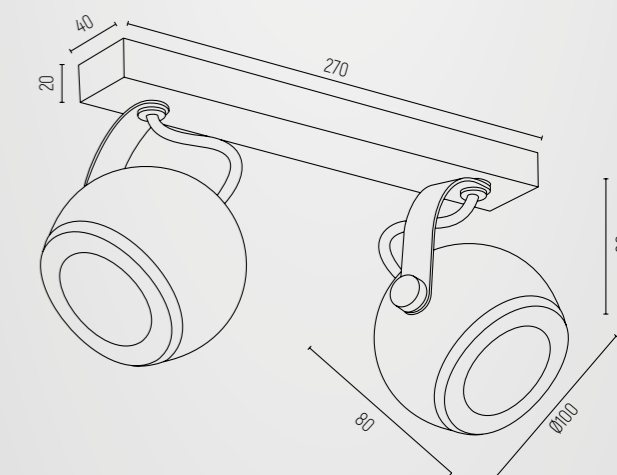

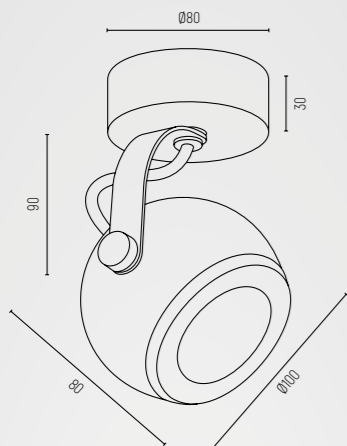



KOS PLUS 7039









KOS

-  **3519, 749** – biały struktura, el. chromowane
-  **3521, 751** – czarny struktura, el. chromowane
-  stal lakierowana, stal chromowana
-  IP 20
-  możliwość regulacji

-  **3519, 3521** – kinkiet 1 pt.
-  GU10 (nie zawiera źródła światła) / 230V | 1 x 5W (max)
-  150 wys. | 100 szer. | 100 g.
-  0,4

-  **749, 751** – plafon 2 pt.
-  GU10 (nie zawiera źródła światła) / 230V | 2 x 5W (max)
-  150 wys. | 340 szer. | 100 g.
-  0,8

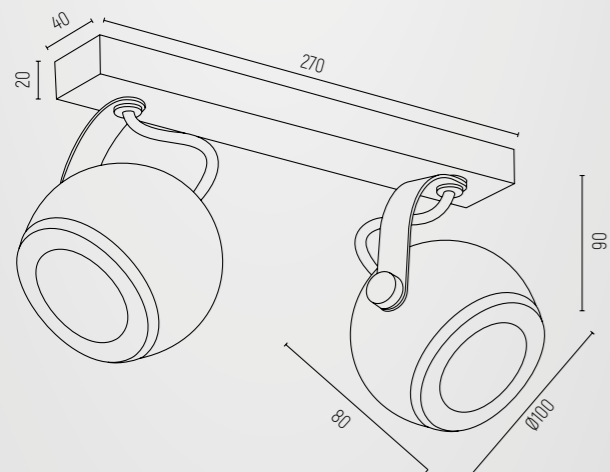

KOS 3519



KOS 3521



KOS 749



KOS 751







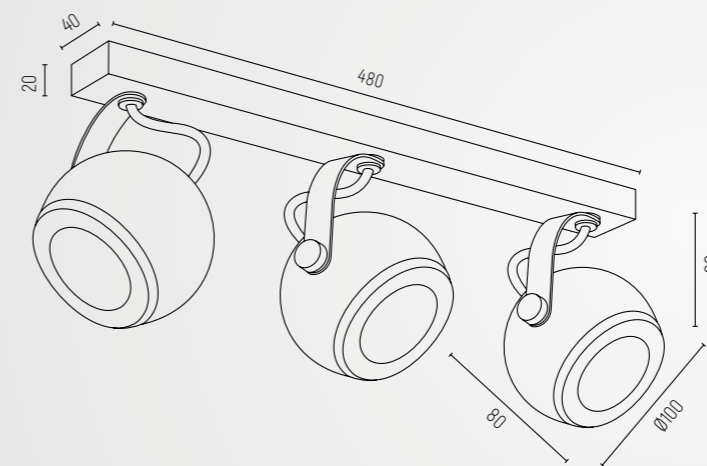

KOS 1261



KOS 1263



KOS

-  **1261** – biały struktura, el. chromowane
-  **1263** – czarny struktura, el. chromowane
-  plafon 3 pt.
-  stal lakierowana, stal chromowana
-  GU10 (nie zawiera źródła światła) / 230V | 3 x 5W (max)
-  150 wys. | 480 szer. | 100 g.
-  1,2
-  IP 20
-  możliwość regulacji

KONGO 3174



KONGO 672

KONGO 4160



KONGO 875

KONGO 3175



KONGO 673

KONGO 4161





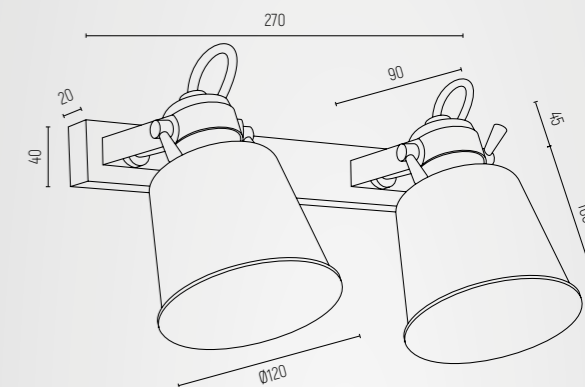
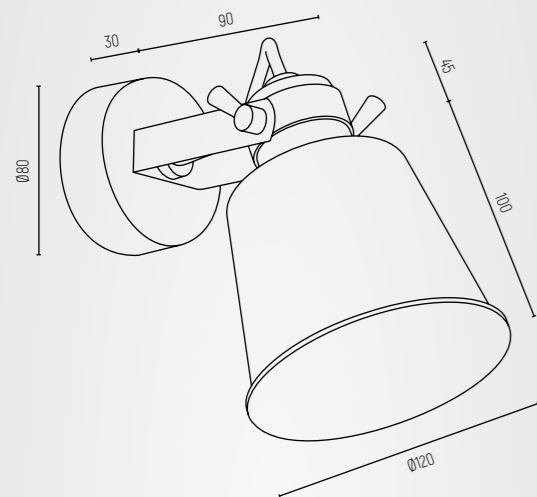







KONGO 876







KONGO

-  3174 - biały struktura, el. chromowane
-  4160 - biały struktura, el. mosiądzowane
-  3175 - czarny struktura, el. chromowane
-  4161 - czarny struktura, el. mosiądzowane
-  kinkiet 1 pt.
-  3174, 3175 - stal lakierowana, stal chromowana
4160, 4161 - stal lakierowana, stal mosiądzowana
-  E27 (nie zawiera źródła światła) / 230V | 1 x 15W (max)
-  160 wys. | 120 szer. | 245 gł.
-  0,42
-  IP 20
-  możliwość regulacji/możliwość zamontowania włącznika na przycienniku

KONGO

-  672 - biały struktura, el. chromowane
-  875 - biały struktura, el. mosiądzowane
-  673 - czarny struktura, el. chromowane
-  876 - czarny struktura, el. mosiądzowane
-  kinkiet 2 pt.
-  672, 673 - stal lakierowana, stal chromowana
4160, 4161 - stal lakierowana, stal mosiądzowana
-  E27 (nie zawiera źródła światła) / 230V | 2 x 15W (max)
-  160 wys. | 350 szer. | 245 gł.
-  0,89
-  IP 20
-  możliwość regulacji



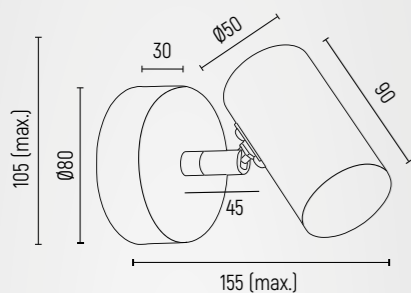

LAGOS

-  **4208, 889** - mosiądz, czarna struktura
-  **4209, 890** - biały struktura, el. mosiądzowane
-  **4210, 891** - czarna struktura, el. mosiądzowane
-  stal lakierowana, stal mosiądzowana
-  IP 20

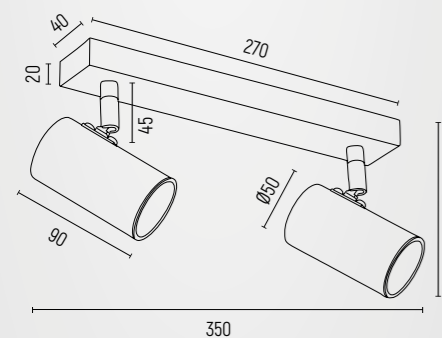

-  **4208, 4209, 4210** - kinkiet 1 pt.
-  GU10 (nie zawiera źródła światła) / 230V | 1 x 5W (max)
-  90 wys. | 80 szer. | max. 155 gł.
-  0,26
-  możliwość zamontowania jako plafon, możliwość regulacji, możliwość zamontowania włącznika na przyścienniku, możliwość zastosowania el. chromowanych lub lakierowanych zamiast el. mosiądzowanych



-  **889, 890, 891** - plafon 2 pt.
-  GU10 (nie zawiera źródła światła) / 230V | 2 x 5W (max)
-  145 wys. | 350 szer. | max. 90 gł.
-  0,54
-  możliwość zamontowania jako kinkiet, możliwość regulacji, możliwość zastosowania el. chromowanych lub lakierowanych zamiast el. mosiądzowanych



LAGOS 4208



LAGOS 4209



LAGOS 4210



LAGOS 889



LAGOS 890



LAGOS 891



LAGOS 1474





LAGOS 1475

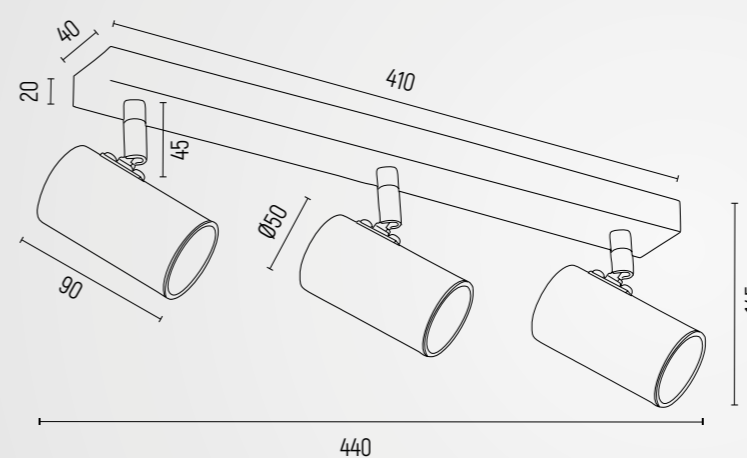

LAGOS 1476



LAGOS

-  **1474** - mosiądz, czarna struktura
-  **1475** - biały struktura, el. mosiądzowane
-  **1476** - czarna struktura, el. mosiądzowane
-  plafon 3 pt.
-  stal lakierowana, stal mosiądzowana
-  GU10 (nie zawiera źródła światła) / 230V | 3 x 5W (max)
-  145 wys. | 440 szer. | max. 90 gł.
-  0,8
-  IP 20
-  możliwość zamontowania jako kinkiet, możliwość regulacji, możliwość zastosowania el. chromowanych lub lakierowanych zamiast el. mosiądzowanych

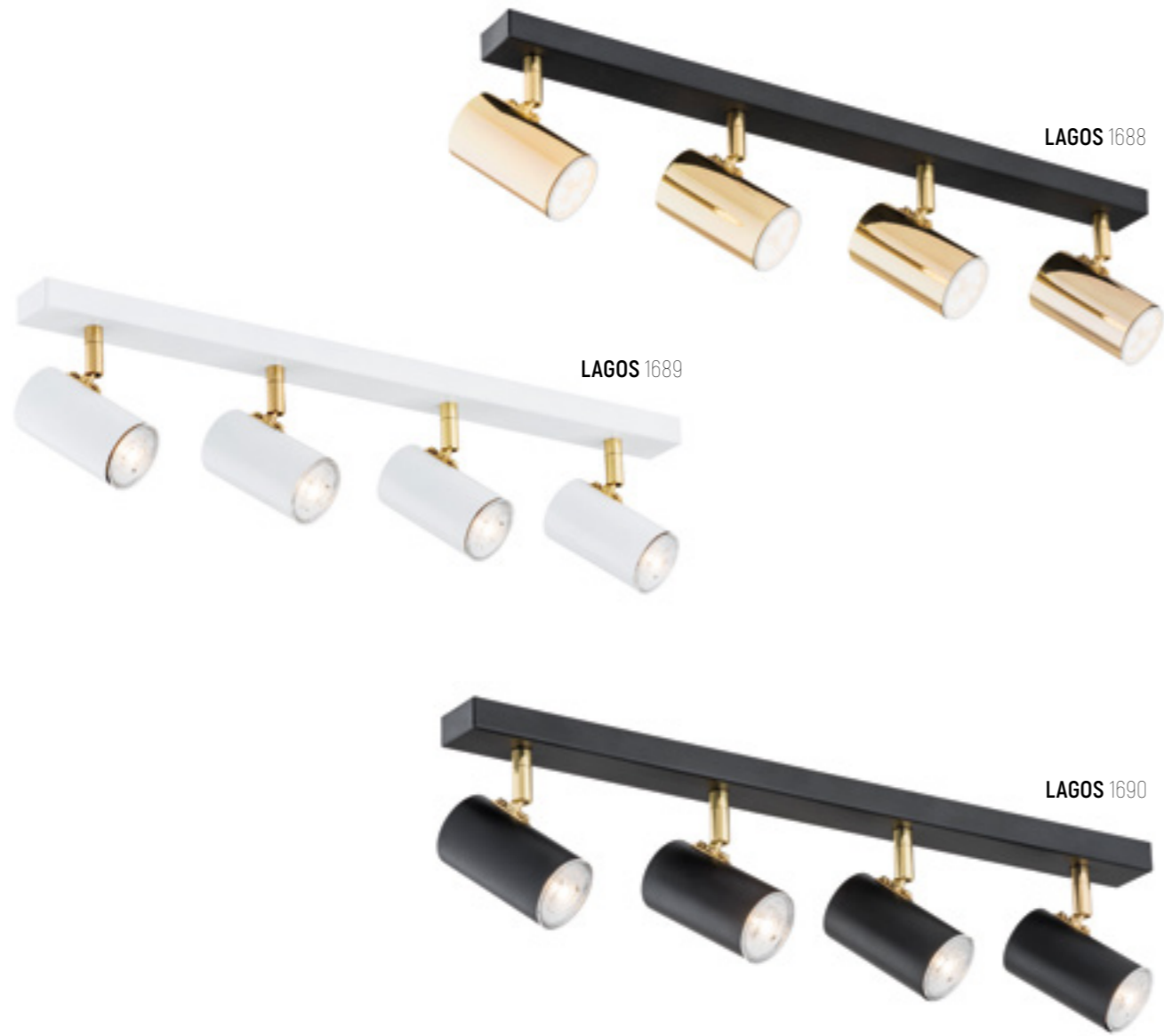





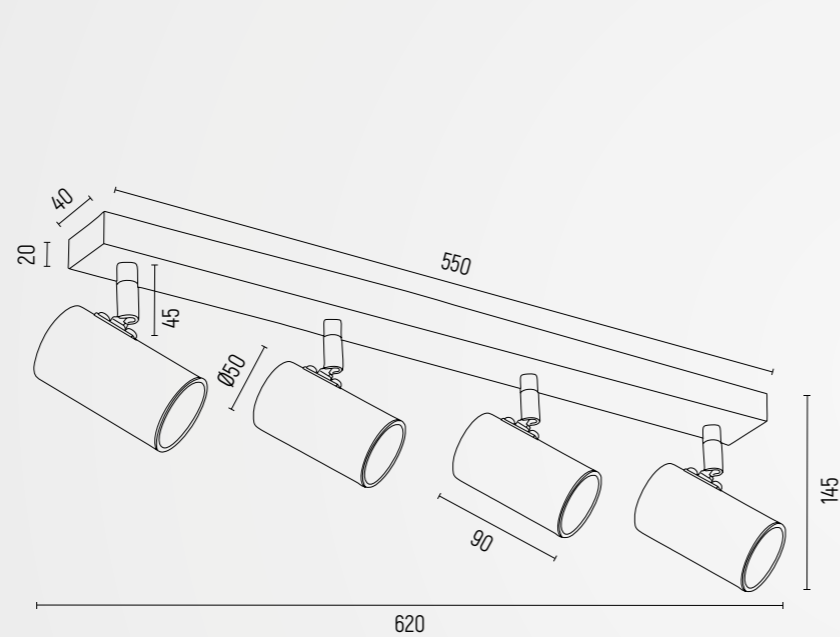



LAGOS

-  **1688** - mosiądz, czarny struktura
-  **1689** - biały struktura, el. mosiądzowane
-  **1690** - czarny struktura, el. mosiądzowane
-  plafon 4 pt.
-  stal lakierowana, stal mosiądzowana
-  GU10 (nie zawiera źródła światła) / 230V | 4 x 5W (max)
-  145 wys. | 620 szer. | max. 90 gł.
-  1,1
-  IP 20
-  możliwość zamontowania jako kinkiet, możliwość regulacji, możliwość zastosowania el. chromowanych lub lakierowanych zamiast el. mosiądzowanych





LAGUNA

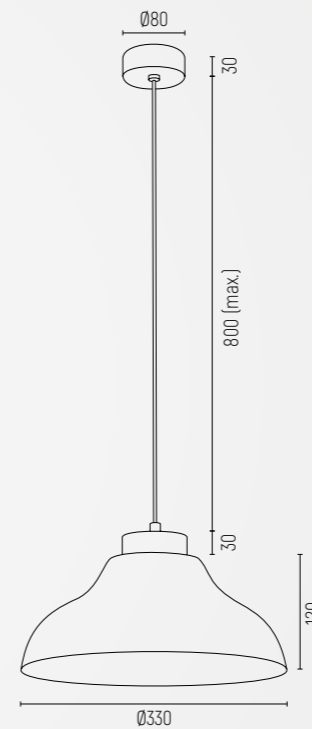



-  **4091** - opal mat, czarny mat
-  **4092** - opal mat, chrom
-  **4093** - opal mat, mosiądz
-  lampa wisząca 1 pt.
-  **4091** - szkło, stal lakierowana, **4092** - szkło, stal chromowana, **4093** - szkło, stal mosiądzowana,
-  E27 (nie zawiera źródła światła) / 230V | 1 x 15W (max)
-  1000 (przewód 800) wys. | 330 szer. | 330 gł.
-  1,4
-  IP 20



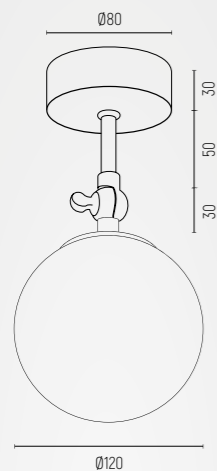



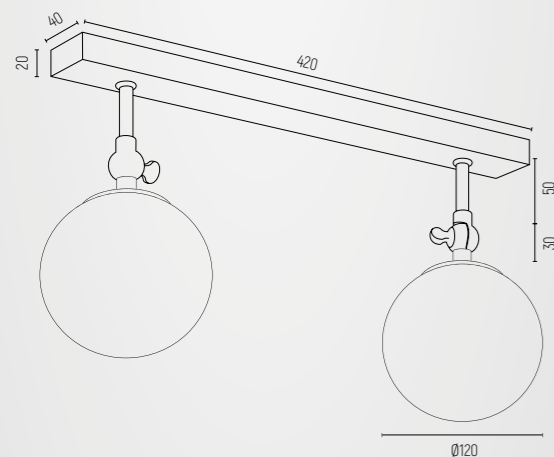

LATINA

-  4001, 844 – opal mat, mosiądz
-  4002, 845 – opal mat, biały mat, mosiądz
-  4003, 846 – opal mat, czarny mat, mosiądz
-  4001, 844 – szkło, stal mosiądzowana
-  4002, 4003, 845, 846 – szkło, stal lakierowana, stal mosiądzowana
-  IP 44



-  4001, 4002, 4003 – kinkiet 1 pt.
-  E14 (nie zawiera źródła światła) / 230V | 1 x 7W (max)
-  240 wys. | 120 szer. | 120 g.
-  0,5



-  844, 845, 846 – kinkiet 2 pt.
-  E14 (nie zawiera źródła światła) / 230V | 2 x 7W (max)
-  220 wys. | 430 szer. | 120 g.
-  0,96
-  możliwość wykonania modyfikacji na włączanie 1+1, możliwość zastosowania el. chromowanych lub lakierowanych zamiast el. mosiądzowanych

LATINA 4001



LATINA 4002



LATINA 4003



LATINA 844



LATINA 845



LATINA 846



LATINA 1435



LATINA 1434



LATINA 1436

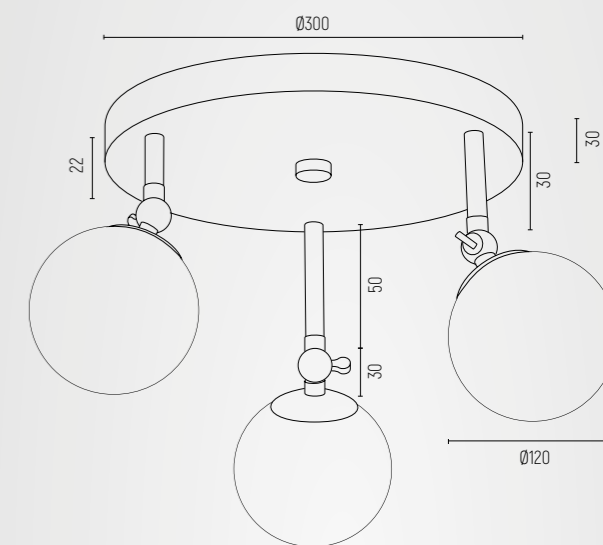

LATINA

-  1435 – opal mat, mosiądz
-  1434 – opal mat, biały mat, mosiądz
-  1436 – opal mat, czarny mat, mosiądz
-  plafon 3 pt.
-  1435 – szkło, stal mosiądzowana
-  1434, 1436 – szkło stal lakierowana, stal mosiądzowana
-  E14 (nie zawiera źródła światła) / 230V | 3 x 7W (max)
-  230 wys. | 350 szer. | 350 g.
-  1,5
-  IP 44
-  możliwość wykonania modyfikacji na włączanie 1+2, możliwość zastosowania el. chromowanych lub lakierowanych zamiast el. mosiądzowanych











LILLE 3839



LILLE 3840





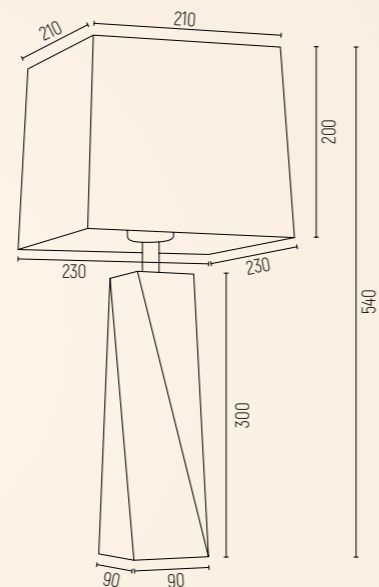

LILLE



-  **3839** - błękitny, transparentny, chrom
-  **3840** - srebrny, kolor lister miodowy, chrom
-  lampa stołowa 1 pt.
-  abażur, szkło, stal chromowana
-  E27 (nie zawiera źródła światła) / 230V | 1 x 15W (max)
-  540 wys. | 230 szer. | 230 gł.
-  2,5
-  IP 20



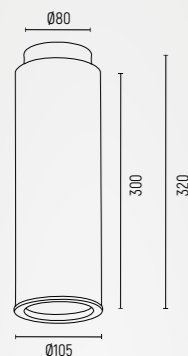

LINEA

-  złoty, czarna struktura
-  abażur, stal lakierowana
-  E27 (nie zawiera źródła światła) / 230V | 1 x 15W (max)
-  0,5
-  IP 20

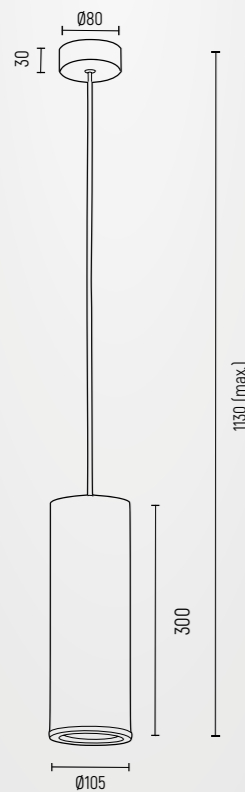

-  4281 - plafon 1 pt.
-  320 wys. | 105 szer. | 105 g.



-  4246 - lampa wisząca 1 pt.
-  przewód max. 800, całość 1130 wys. | 105 szer. | 105 g.



LINEA 4281



LINEA 4246





LINEA 1486







LINEA 1693

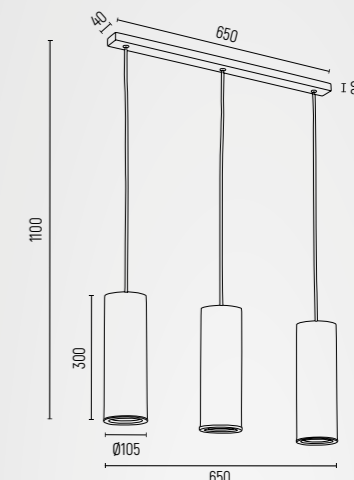



LINEA

-  złoty, czarna struktura
-  abażur, stal lakierowana
-  IP 20

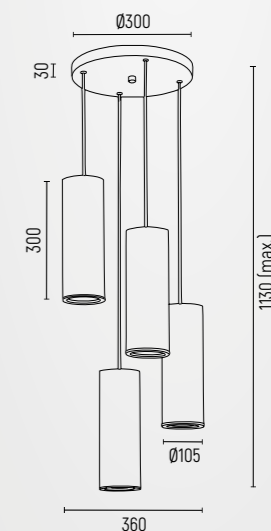

-  1486 - lampa wisząca 3 pt. listwa
-  E27 (nie zawiera źródła światła) / 230V | 3 x 15W (max)
-  przewód max. 800, całość 1120 wys. | 650 szer. | 105 g.
-  1,3
-  możliwość modyfikacji na włączenie 1+2



-  1693 - lampa wisząca 4 pt. na okrągłej podsufitce
-  E27 (nie zawiera źródła światła) / 230V | 4 x 15W (max)
-  przewód max. 800, całość 1130 wys. | 360 szer. | 360 g.
-  1,6
-  możliwość modyfikacji na włączenie 2+2

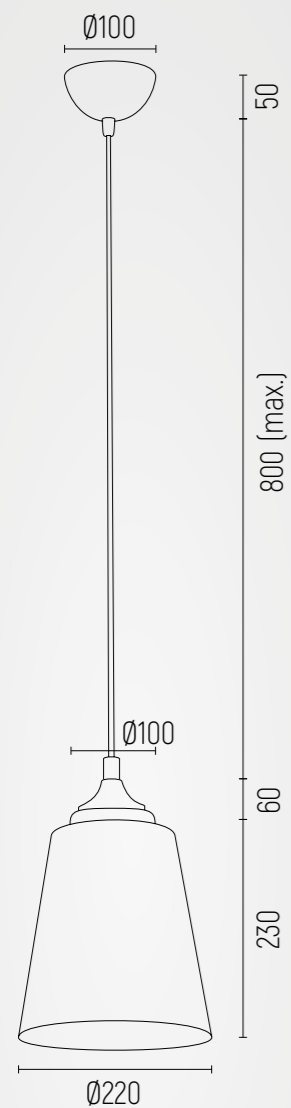

LIRANO

- 305 - opal mat, chrom
- 🏠 lampa wisząca 1 pt.
- 🏠 szkło, stal chromowana
- 💡 E27 (nie zawiera źródła światła) / 230V | 1 x 15W (max)
- 📏 1100 (przewód 800) wys. | 220 szer. | 220 gt.
- 🏠 1,36
- 🏠 IP 20



LIRANO 305

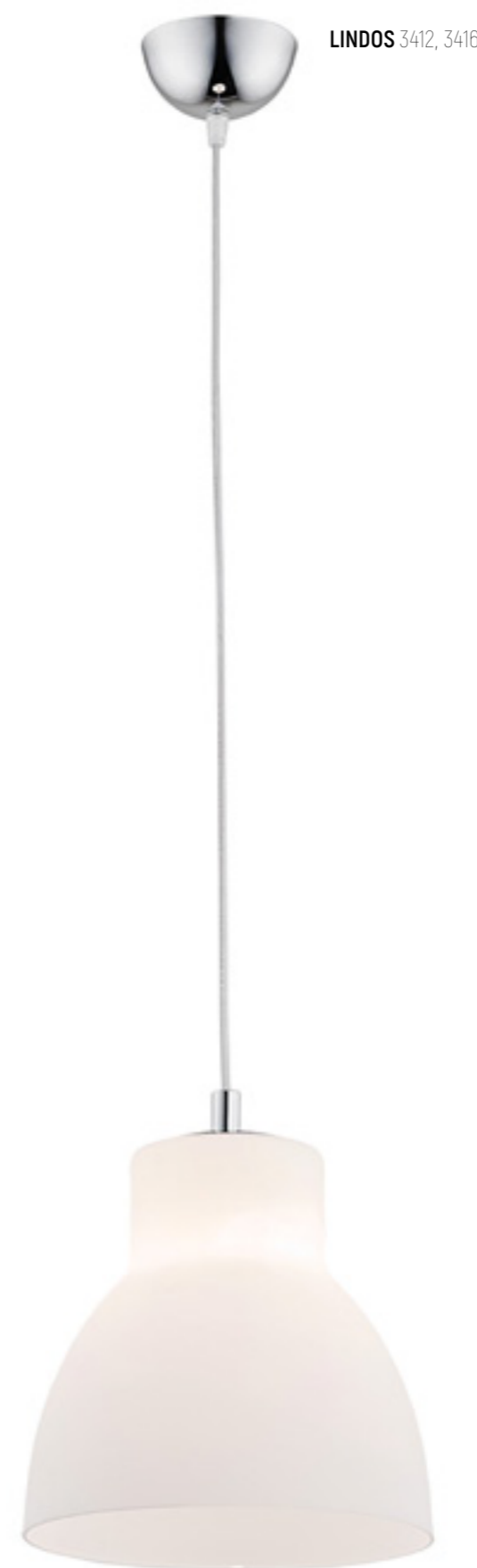

LINDOS 3412, 3416

LINDOS

- opal mat, chrom
- 🏠 szkło, stal chromowana
- 💡 E27 (nie zawiera źródła światła) / 230V | 1 x 15W (max)
- 🏠 IP 20

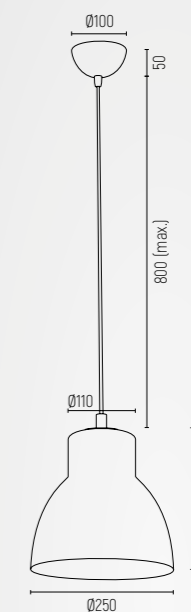

- 🏠 3412 - lampa wisząca 1 pt. mniejsza
- 📏 1100 (przewód 800) wys. | 250 szer. | 250 gt.
- 🏠 2,1

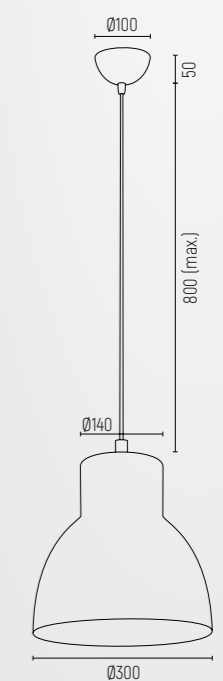

- 🏠 3416 - lampa wisząca 1 pt. większa
- 📏 1150 (przewód 800) wys. | 300 szer. | 300 gt.
- 🏠 2,36

LIVIA

4031, 4029 - opal mat, mosiądz

4032, 4030 - opal mat, chrom

4031, 4029 - szkło, stal mosiądzowana
4032, 4030 - szkło, stal chromowana

IP 44

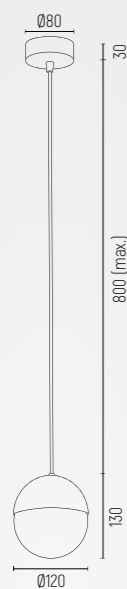

4031, 4032 - lampa wisząca 1 pt. mniejsza

E14 (nie zawiera źródła światła) / 230V | 1 x 7W (max)

960 (przewód 800) wys. | 120 szer. | 120 gt.

1,1



4029, 4030 - lampa wisząca 1 pt. większa

E27 (nie zawiera źródła światła) / 230V | 1 x 15W (max)

1000 (przewód 800) wys. | 200 szer. | 200 gt.

1,4

LIVIA 4031



LIVIA 4032



LIVIA 4029



LIVIA 4030



LIVIA 1416



LIVIA 1417

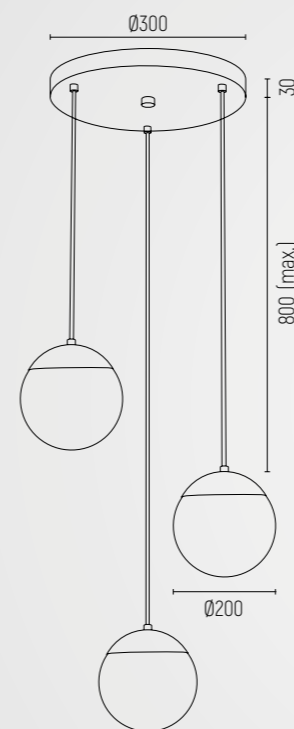

LIVIA

1416 - opal mat, mosiądz

1417 - opal mat, czarna struktura, mosiądz

lampa wisząca 3 pt.

1416 - szkło, stal mosiądzowana

1417 - szkło, stal lakierowana, stal mosiądzowana

E14 (nie zawiera źródła światła) / 230V | 3 x 7W (max)

970 (przewód 800) wys. | 370 szer. | 370 gt.

2,5

IP 44

możliwość modyfikacji na włączanie 1+2



LORENA 355



LORENA 356



LORENA 357



LORENA 365













LORENA 366



LORENA 365

LORENA



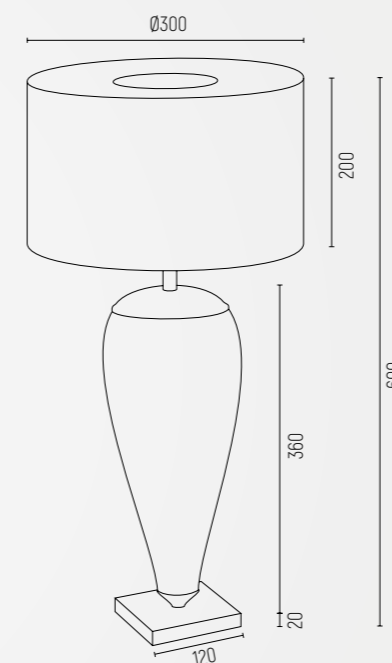
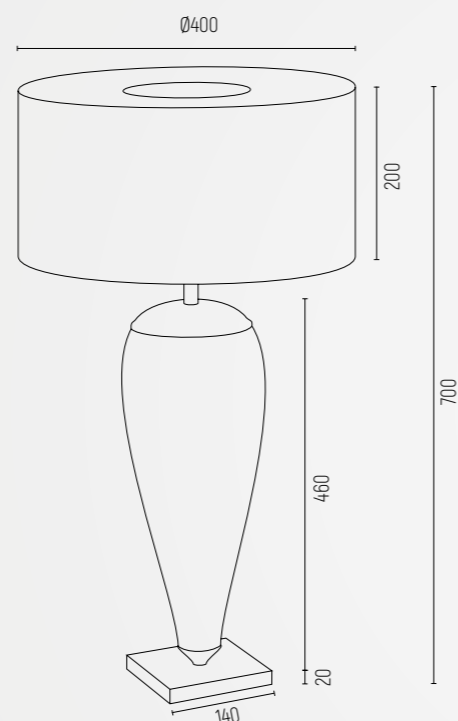

-  355 - biały, czarny, chrom
-  356 - biały, transparentny, chrom
-  357 - biały, opal, chrom
-  lampa stołowa 1 pł. większa
-  abażur, szkło, stal chromowana
-  E27 (nie zawiera źródła światła) / 230V | 1 x 15W (max)
-  700 wys. | 400 szer. | 400 gł.
-  4,2
-  IP 20
-  abażur zawsze walec biały (gładki z chromowanym paskiem)







LORENA

-  365 - biały, czarny, chrom
-  366 - biały, transparentny, chrom
-  367 - biały, opal, chrom
-  lampa stołowa 1 pł. mniejsza
-  abażur, szkło, stal chromowana
-  E27 (nie zawiera źródła światła) / 230V | 1 x 15W (max)
-  600 wys. | 300 szer. | 300 gł.
-  1,9
-  IP 20
-  abażur zawsze walec biały (gładki z chromowanym paskiem)

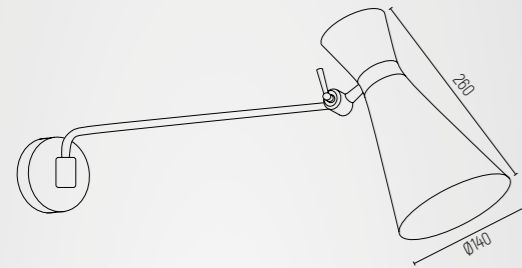



LUKKA

-  **3889, 3890** – biały struktura, el. chromowane
-  **3893, 3894** – czarny struktura, el. chromowane
-  stal lakierowana, stal chromowana
-  E27 (nie zawiera źródła światła) / 230V | 1 x 15W (max)
-  IP 20

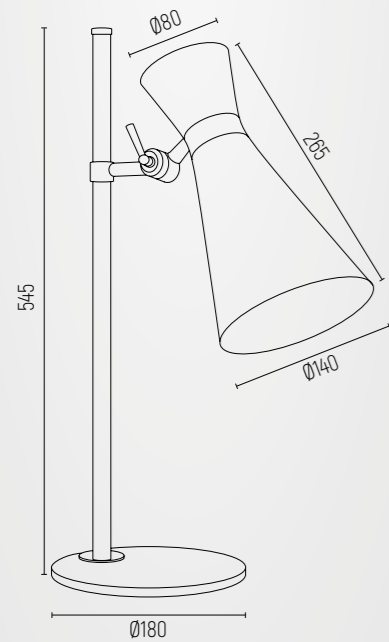

-  **3889, 3893** – kinkiet 1 pt.
-  260 wys. | 140 szer. | 580 g.
-  1,3
-  możliwość regulacji/możliwość zamontowania włącznika na przyścienniku, możliwość zastosowania el. mosiądzowanych lub lakierowanych zamiast el. chromowanych



-  **3890, 3894** – lampa biurkowa 1 pt.
-  530 wys. | 180 szer. | ok. 280 g.
-  1,4
-  możliwość regulacji, możliwość zastosowania el. mosiądzowanych lub lakierowanych zamiast el. chromowanych



LUKKA 3889



LUKKA 3893



LUKKA 3890



LUKKA 3894









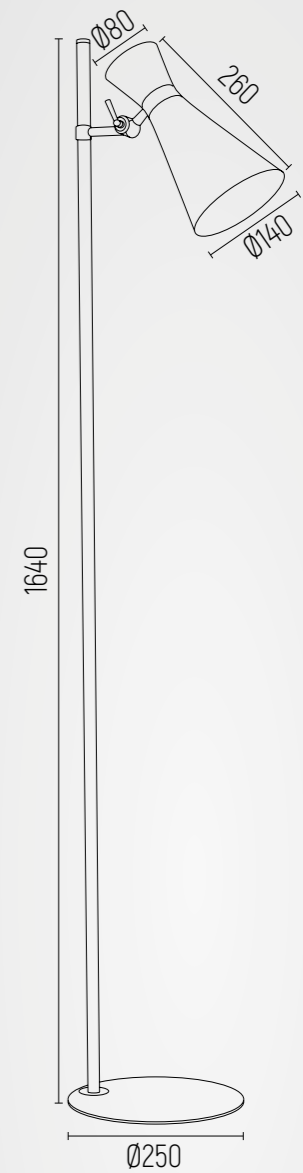

LUKKA 3891



LUKKA 3895







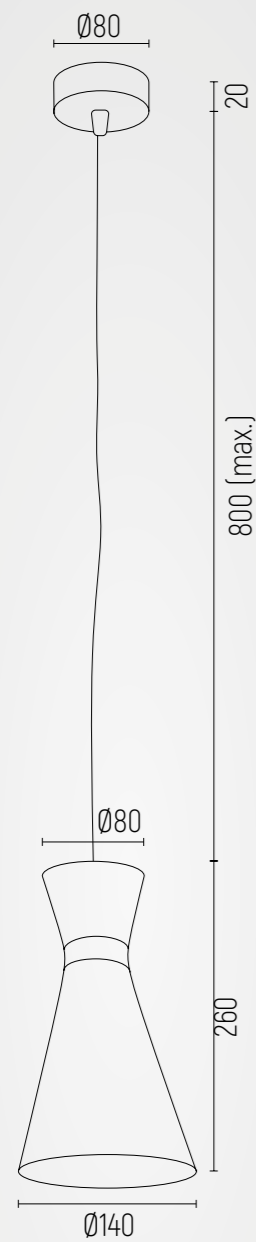



LUKKA

-  **3891** – biały struktura, el. chromowane
-  **3895** – czarny struktura, el. chromowane
-  lampa podłogowa 1 pt.
-  stal lakierowana, stal chromowana
-  E27 (nie zawiera źródła światła) / 230V | 1 x 15W (max)
-  1640 wys. | 250 szer. | ok. 280 g.
-  4,5
-  IP 20
-  możliwość regulacji, możliwość zastosowania el. mosiądzowanych lub lakierowanych zamiast el. chromowanych



LUKKA

-  **3892** - biały struktura, el. chromowane
-  **3896** - czarny struktura, el. chromowane
-  lampa wisząca 1 pt.
-  stal lakierowana, stal chromowana
-  E27 (nie zawiera źródła światła) / 230V | 1 x 15W (max)
-  1080 wys. | 140 szer. | 140 g.
-  0,9
-  IP 20
-  możliwość zastosowania el. mosiądzowanych lub lakierowanych zamiast el. chromowanych



LUKKA 3892



LUKKA 3896









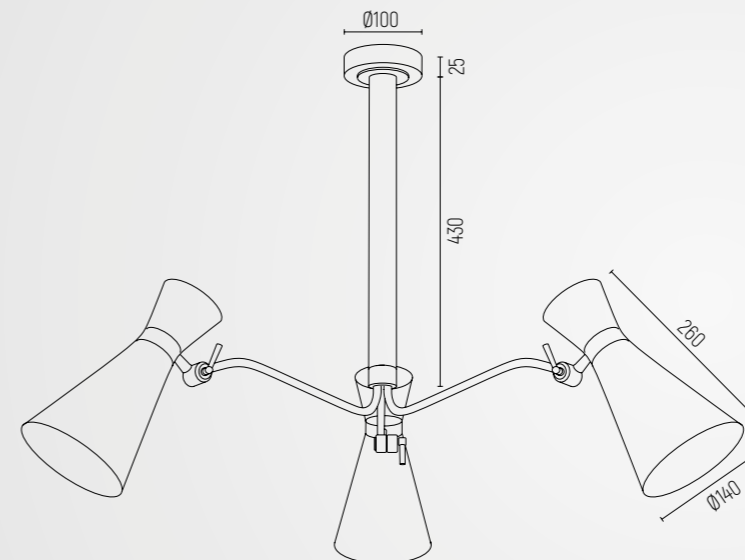

LUKKA 1379



LUKKA 1380







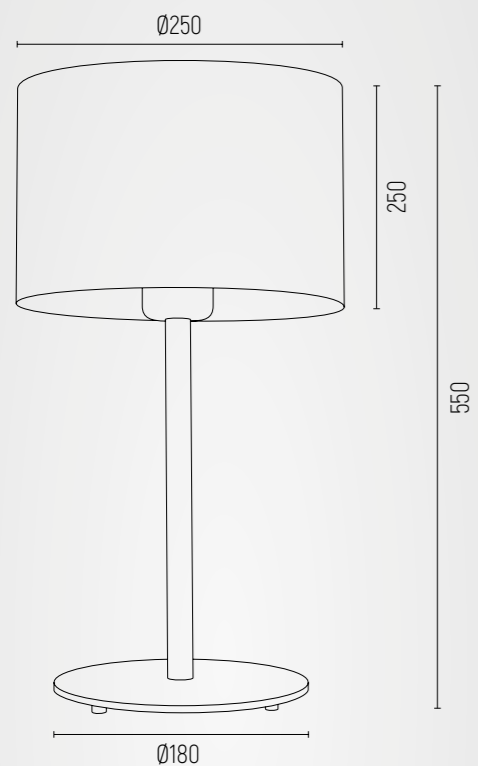





LUKKA

-  **1379** - biały struktura, el. chromowane
-  **1380** - czarny struktura, el. chromowane
-  żyrandol 3 pt.
-  stal lakierowana, stal chromowana
-  E27 (nie zawiera źródła światła) / 230V | 3 x 15W (max)
-  710 wys. | 600 szer. | ok. 600 g.
-  3,8
-  IP 20
-  możliwość regulacji/możliwość modyfikacji na włączanie 1+2, możliwość zastosowania el. mosiądzowanych lub lakierowanych zamiast el. chromowanych



MAGIC

-  **4125** - biały w szare gwiazdki, biały struktura
-  **4126** - szary w białe gwiazdki, biały struktura
-  **4127** - mięta, biały struktura
-  **4128** - róż, biały struktura
-  lampa stołowa 1 pt.
-  abażur, stal lakierowana
-  E27 (nie zawiera źródła światła) / 230V | 1 x 15W (max)
-  550 wys. | 250 szer. | 250 gł.
-  1,6
-  IP 20

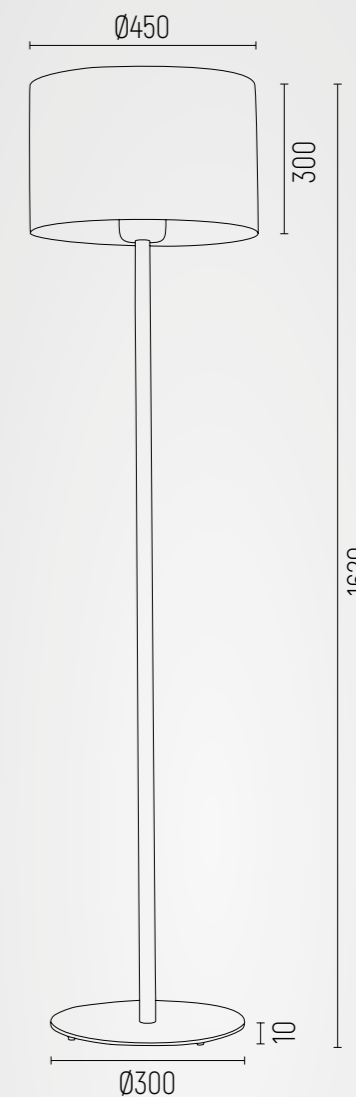

MAGIC

-  **4129** - biały w szare gwiazdki, biały struktura
-  **4130** - szary w białe gwiazdki, biały struktura
-  **4131** - mięta, biały struktura
-  **4132** - róż, biały struktura
-  lampa podłogowa 1 pt.
-  abażur, stal lakierowana
-  E27 (nie zawiera źródła światła) / 230V | 1 x 15W (max)
-  1620 wys. | 450 szer. | 450 gł.
-  4,9
-  IP 20



MAGIC

-  4133 - biały w szare gwiazdki, el. chromowane
-  4134 - szary w białe gwiazdki, el. chromowane
-  4135 - mięta, el. chromowane
-  4136 - róż, el. chromowane
-  lampa wisząca 1 pt.
-  abażur, stal chromowana
-  E27 (nie zawiera źródła światła) / 230V | 1 x 15W (max)
-  1100 (przewód 900) wys. | 440 szer. | 440 g.
-  0,7
-  IP 20
-  możliwość zastosowania podsufitki lakierowanej np. na kolor biały

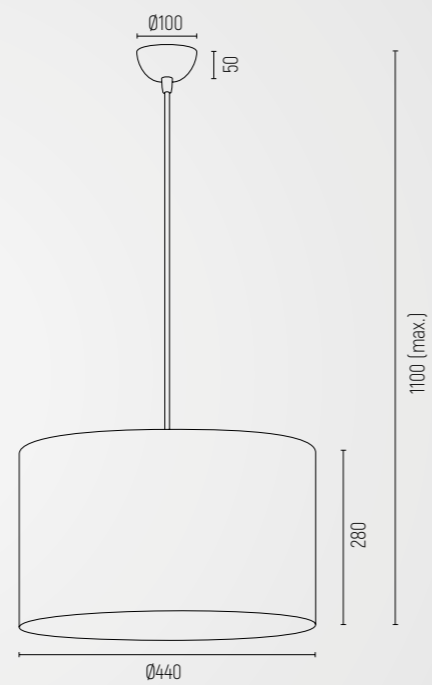



MARBELLA PLUS 8120



MARBELLA PLUS 8121



MARBELLA 4255









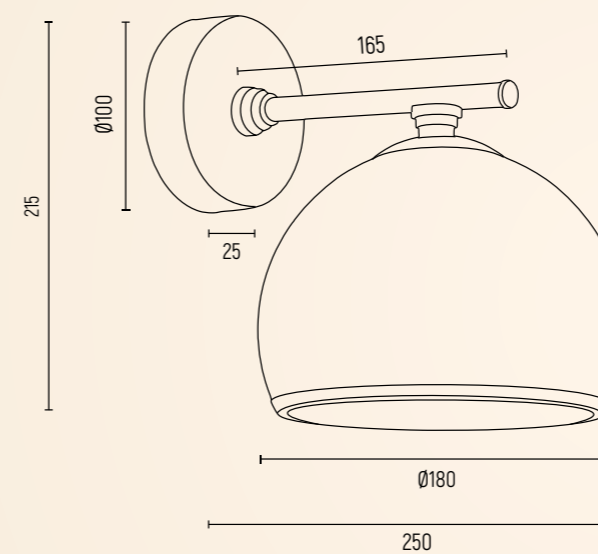
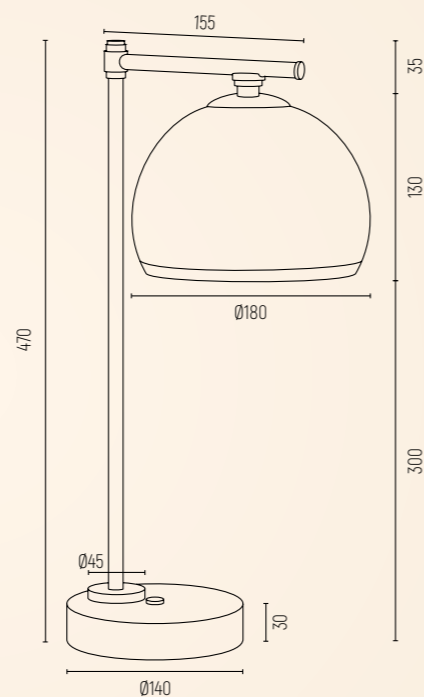



MARBELLA 4254

MARBELLA

-  **8120** - opal mat, mosiądz
-  **8121** - opal mat, chrom
-  lampa stołowa 1 pt.
-  **8120** - szkło, stal mosiądzowana
-  **8121** - szkło, stal chromowana
-  E27 (nie zawiera źródła światła) / 230V | 1 x 15W (max)
-  470 wys. | 180 szer. | 240 g.
-  1
-  IP 20



MARBELLA

-  **4254** - opal mat, chrom
-  **4255** - opal mat, mosiądz
-  kinkiet 1 pt.
-  **4254** - szkło, stal chromowana
-  **4255** - szkło, stal mosiądzowana
-  E27 (nie zawiera źródła światła) / 230V | 1 x 15W (max)
-  215 wys. | 180 szer. | 250 g.
-  0,9
-  IP 20
-  możliwość zamontowania włącznika na przyścienniku

MARBELLA 1488



MARBELLA 2087













MARBELLA 2088



MARBELLA 1487







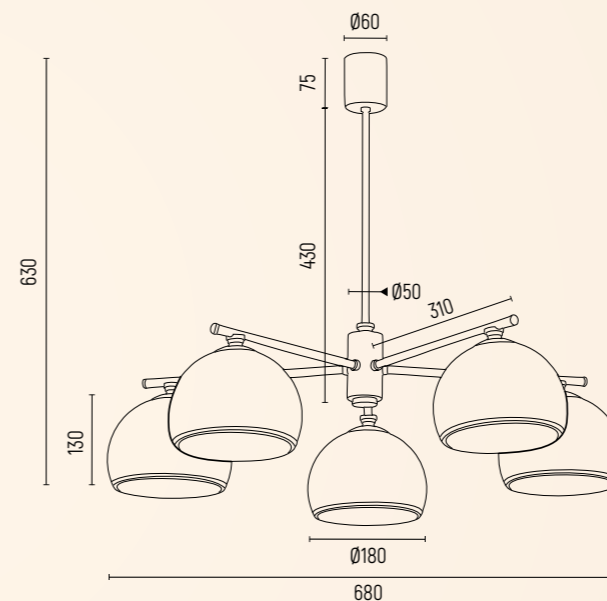
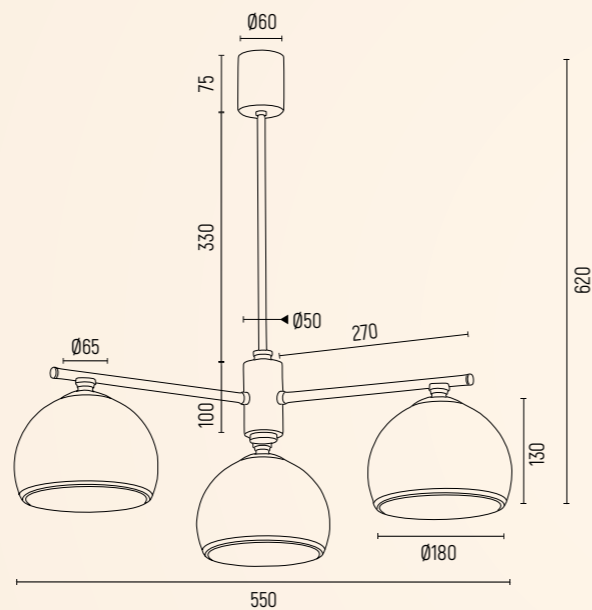



MARBELLA

-  1487 - opal mat, chrom
-  1488 - opal mat, mosiądz
-  żyrandol 3 pt.
-  1487 - szkło, stal chromowana
-  1488 - szkło, stal mosiądzowana
-  E27 (nie zawiera źródła światła) / 230V | 3 x 15W (max)
-  620 wys. | 550 szer. | 550 gł.
-  2,5
-  IP 20
-  możliwość modyfikacji na włączanie 1+2













MARBELLA

-  2087 - opal mat, chrom
-  2088 - opal mat, mosiądz
-  żyrandol 5 pt.
-  2087 - szkło, stal chromowana
-  2088 - szkło, stal mosiądzowana
-  E27 (nie zawiera źródła światła) / 230V | 5 x 15W (max)
-  630 wys. | 680 szer. | 680 gł.
-  4,3
-  IP 20
-  możliwość modyfikacji na włączanie 3+2







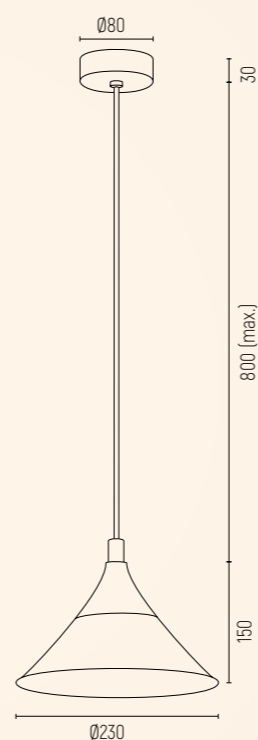
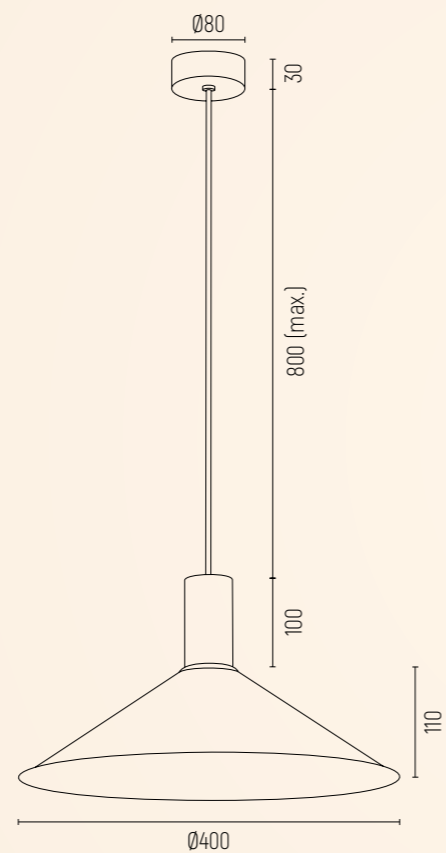







MINORI

-  **4911** - biały struktura, el. miedziane
-  **4912** - czarny struktura, el. miedziane
-  **4913** - szafiowa struktura, el. miedziane
-  lampa wisząca 1 pt.
-  stal lakierowana, stal miedziana
-  E27 (nie zawiera źródła światła) / 230V | 1 x 15W (max)
-  1040 wys. | 400 szer. | 400 g.
-  1
-  IP 20
-  możliwość zastosowania el. chromowanych lub lakierowanych zamiast el. miedzianych







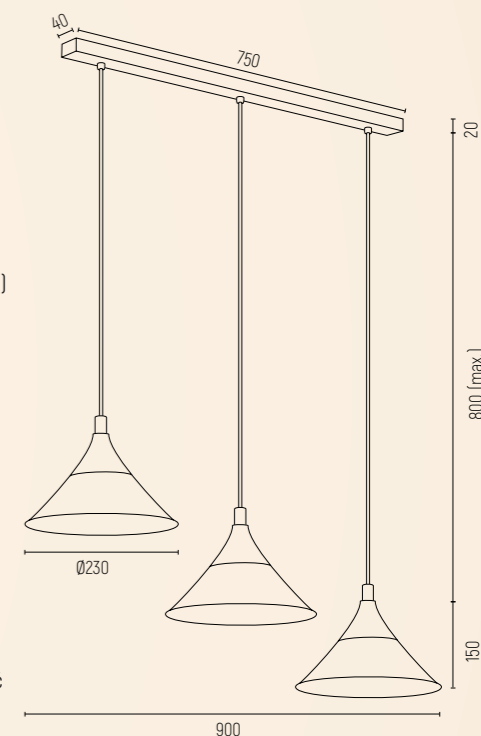

MASSETO





-  czarny struktura, miedziane
-  stal lakierowana, stal miedziana
-  IP 20
-  **4903** - lampa wisząca 1 pt.
-  E27 (nie zawiera źródła światła) / 230V | 1 x 15W (max)
-  980 wys. | 230 szer. | 230 g.
-  0,4
-  **6140** - lampa wisząca 3 pt.
-  E27 (nie zawiera źródła światła) / 230V | 3 x 15W (max)
-  970 wys. | 900 szer. | 230 g.
-  1,6
-  możliwość modyfikacji na włączanie 1+2, możliwość zastosowania el. chromowanych lub lakierowanych zamiast el. miedzianych



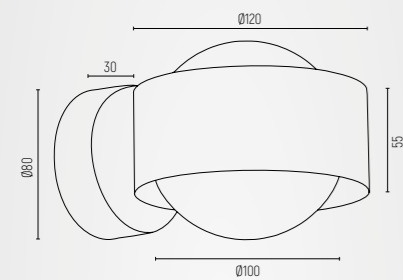



MASSIMO PLUS

-  **8057, 8058** - opal mat, biały struktura
-  **8059, 8060** - opal mat, czarny struktura
-  **8061, 8062** - opal mat, granat struktura
-  szkło, stal lakierowana
-  G9 (nie zawiera źródła światła) / 230V | 1 x 6W LED (max)
-  IP 20

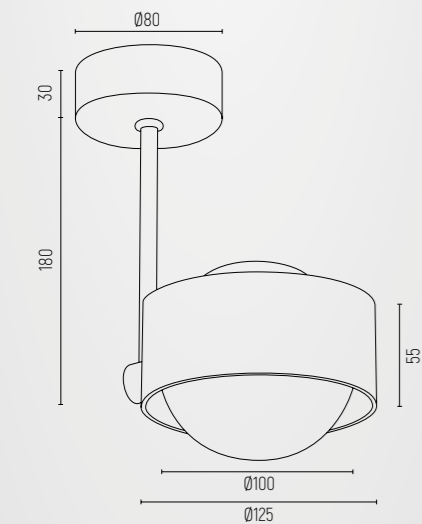

-  **8057, 8059, 8061** - kinkiet 1 pt.
-  100 wys. | 125 szer. | 165 g.
-  0,5
-  możliwość zamontowania włącznika na przyścienniku



-  **8058, 8060, 8062** - lampa wisząca 1 pt.
-  250 wys. | 140 szer. | 125 g.
-  0,6



MASSIMO PLUS 8057

MASSIMO PLUS 8058



MASSIMO PLUS 8059

MASSIMO PLUS 8060



MASSIMO PLUS 8061

MASSIMO PLUS 8062



MASSIMO PLUS 7088



MASSIMO PLUS 7089



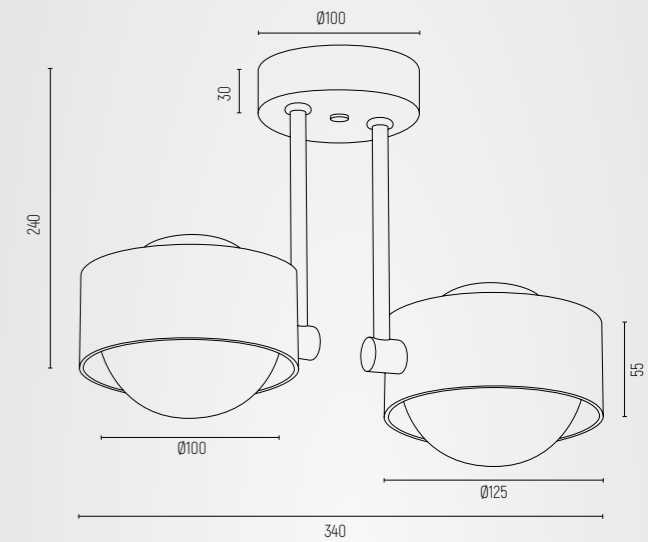

MASSIMO PLUS 7090







MASSIMO PLUS

-  **7088** - opal mat, biały struktura
-  **7089** - opal mat, czarny struktura
-  **7090** - opal mat, granat struktura
-  lampa wisząca 2 pt.
-  szkło, stal lakierowana
-  G9 (nie zawiera źródła światła) / 230V | 2 x 6W LED (max)
-  250 wys. | 340 szer. | 125 g.
-  1,6
-  IP 20

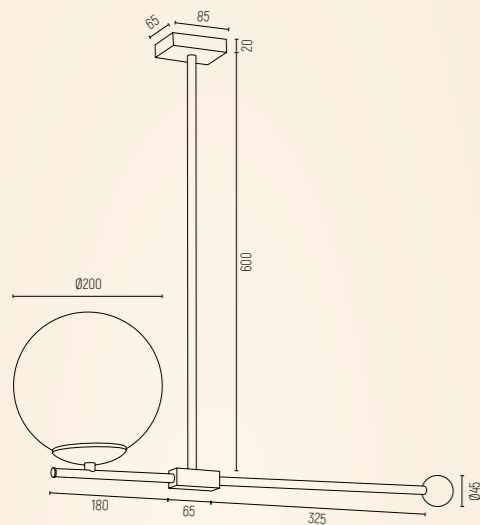



MEGAN

-  opal mat, msiądz szczotkowany, czarny
-  E14 (nie zawiera źródła światła) / 230V | 1 x 7W (max)
-  IP 20

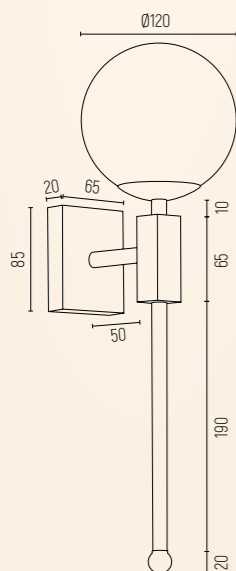

-  4738 - lampa wisząca 1 pt.
-  szkło, msiądz, stal lakierowana, kamień
-  660 wys. | 615 szer. | 200 g.
-  1,9



-  4740 - kinkiet 1 pt.
-  szkło, msiądz, stal lakierowana, kamień
-  405 wys. | 120 szer. | 150 g.
-  0,9
-  możliwość zamontowania włącznika na przyścienniku





MEGAN 4738







MEGAN 4740

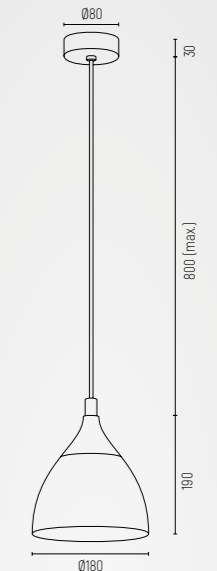



MURANO

-  czarna struktura, msiądz
-  stal lakierowana, stal msiądzowana
-  IP 20

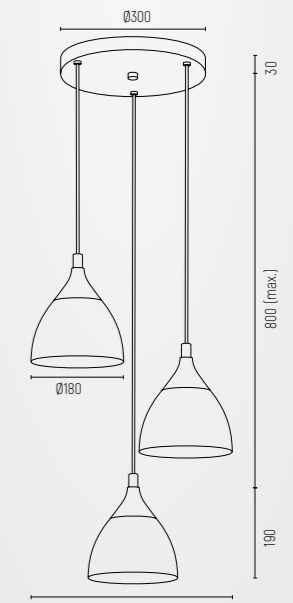

-  4905 - lampa wisząca 1 pt.
-  E27 (nie zawiera źródła światła) / 230V | 1 x 15W (max)
-  1020 wys. | 180 szer. | 180 g.
-  0,4



-  6139 - lampa wisząca 3 pt.
-  E27 (nie zawiera źródła światła) / 230V | 3 x 15W (max)
-  1020 wys. | 380 szer. | 380 g.
-  1,7
-  możliwość modyfikacji na włączanie 1+2
możliwość zastosowania el. chromowanych
lub lakierowanych zamiast el. msiądzowanych



MURANO 6139



MURANO 4905

METIS

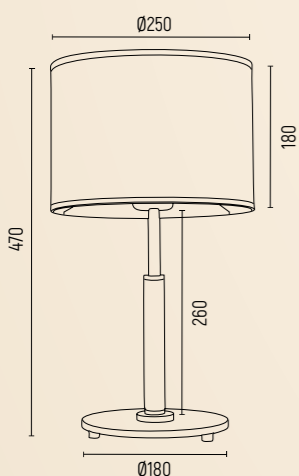
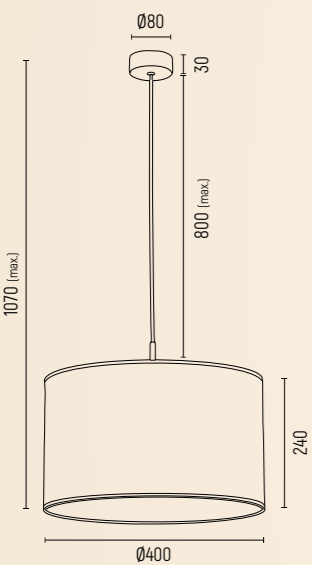
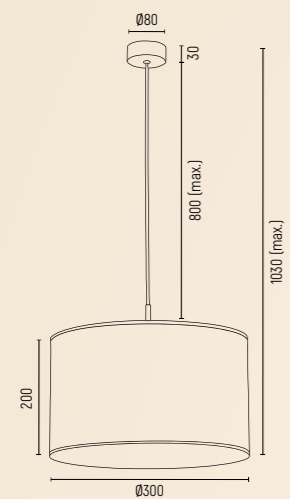

-  **4289, 4345, 4288, 4346** - czarny ze złotym dekokrem, czarna struktura, el. mosiądzowane
-  **4296** - czarny ze złotym dekokrem, czarna struktura
-  **4302** - czarny ze złotym dekokrem, mosiądz
-  E27 (nie zawiera źródła światła) / 230V | 1 x 15W (max)
-  IP 20
-  **4345** - lampa wisząca 1 pt. mniejsza
-  abażur, stal lakierowana, stal mosiądzowana
-  przewód max. 800, całość 1030 wys. | 300 szer. | 300 g.
-  0,6
-  **4288** - lampa wisząca 1 pt. większa
-  abażur, stal lakierowana, stal mosiądzowana
-  przewód max. 800, całość 1070 wys. | 400 szer. | 400 g.
-  0,8
-  **4346** - lampa podłogowa 1 pt.
-  abażur, stal lakierowana, stal mosiądzowana
-  1560 wys. | 400 szer. | 400 g.
-  5,9
-  **4289** - lampa stołowa 1 pt.
-  abażur, stal lakierowana, stal mosiądzowana
-  470 wys. | 250 szer. | 250 g.
-  2,3
-  **4302** - lampa stołowa 1 pt.
-  abażur, stal mosiądzowana
-  440 wys. | 250 szer. | 250 g.
-  1,4
-  **4296** - kinkiet 1 pt.
-  abażur, stal lakierowana
-  260 wys. | 300 szer. | 360 g.
-  0,75
-  możliwość zamontowania włącznika na przyścienniku

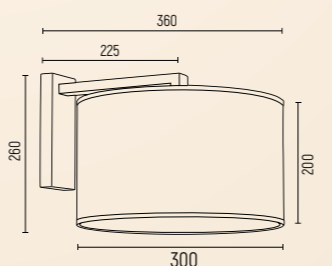
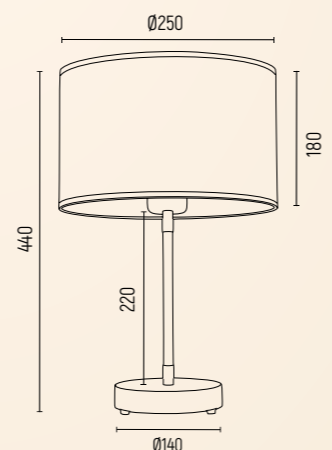
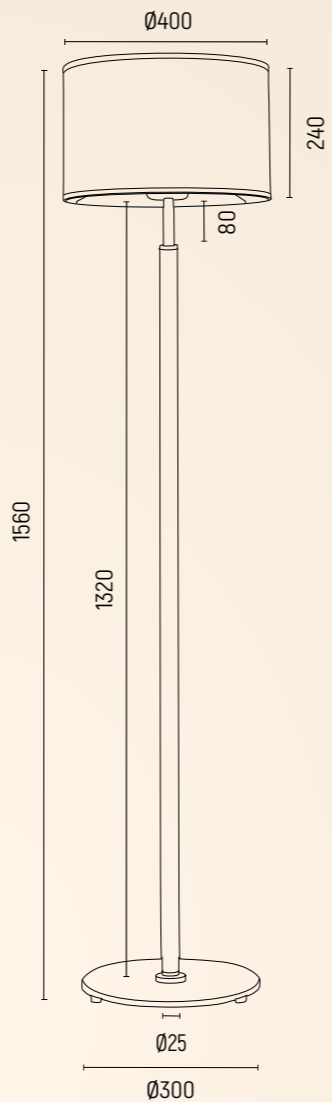

METIS 4346



METIS 4345



METIS 4288



METIS 4289



METIS 4302



METIS 4296

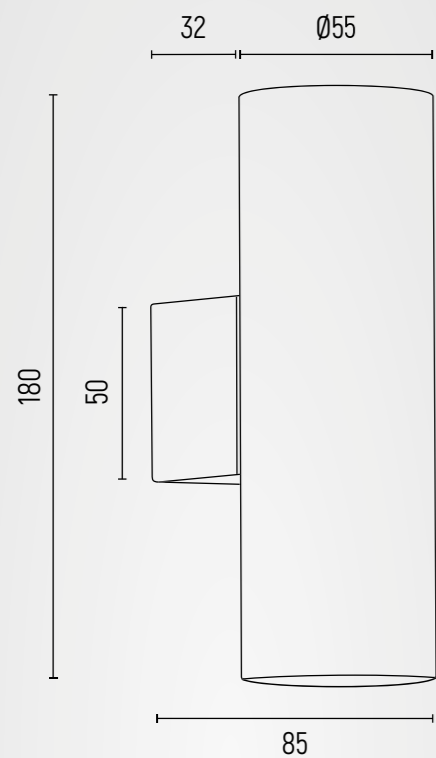

MITOS

● 909 - czarna struktura

○ 910 - biały struktura

● 911 - złoty struktura

● 912 - chrom

● 913 - msiądz

⌘ kinkiet 2 pt.

● 909, 910, 911 - stal lakierowana
● 912 - stal chromowana
● 913 - stal msiądzowana

💡 GU10 (nie zawiera źródła światła) / 230V | 2 x 5W (max)

mm 180 wys. | 55 szer. | 85 gł.

kg 0,5

IP IP 20

+ świeci góra-dół

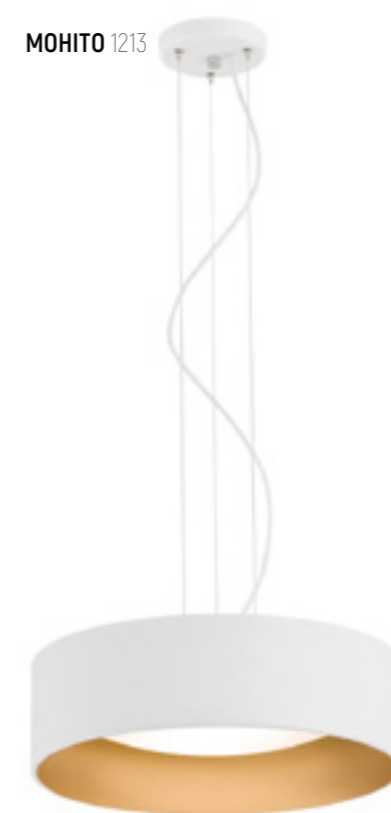

MOHITO

○ 703, 1213 - biały struktura na zewnątrz, złoty wewnątrz

○ 704, 1214 - czarny struktura na zewnątrz, srebrny wewnątrz

⌘ stal lakierowana, szkło

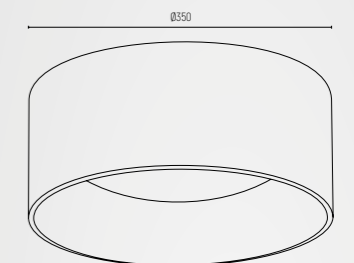

⌘ 703, 704 - plafon 2 pt.

💡 E27 (nie zawiera źródła światła) / 230V | 2 x 15W (max)

mm 130 wys. | 350 szer. | 350 gł.

kg 4,5

IP IP 20

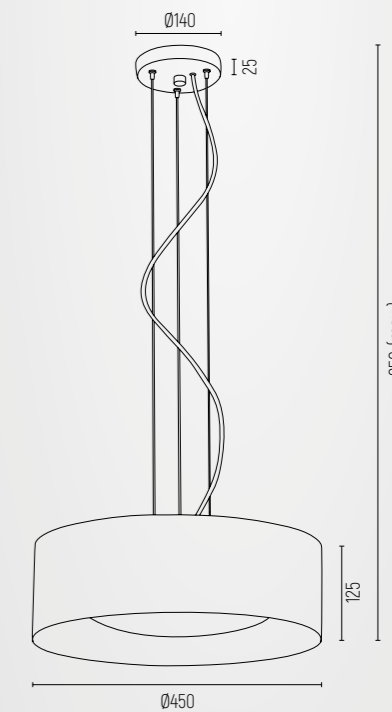

⌘ 1213, 1214 - lampa wisząca 3 pt.

💡 E27 (nie zawiera źródła światła) / 230V | 3 x 15W (max)







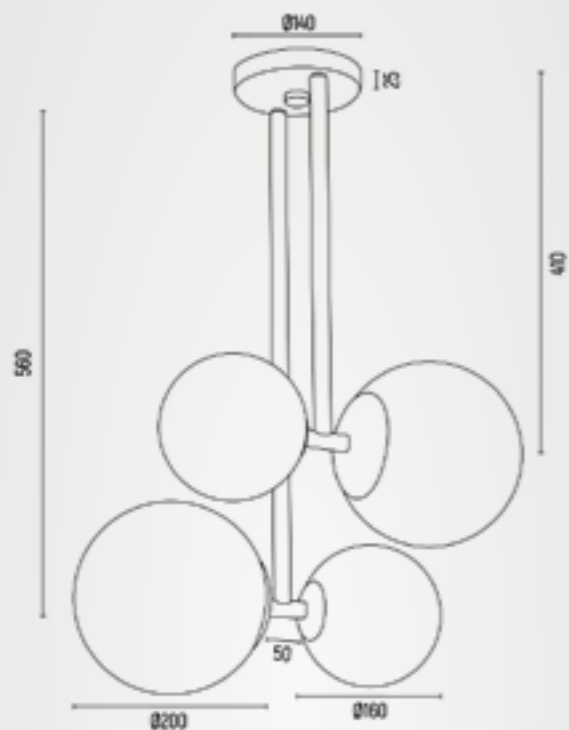

mm 950 (linka 800) wys. | 450 szer. | 450 gł.

kg 6,8

IP IP 20



MORITZ

-  **1739** - opal mat, czarny struktura, el. mosiądzowany
-  **1743** - opal mat, mosiądz
-  lampa wisząca 4 pt.
-  **1739** - szkło, stal lakierowana, stal mosiądzowana
1743 - szkło, stal mosiądzowana
-  E27 (nie zawiera źródła światła) / 230V | 4 x 15W (max)
-  670 wys. | 500 szer. | 500 g.
-  4,1
-  IP 20

MORITZ 1739









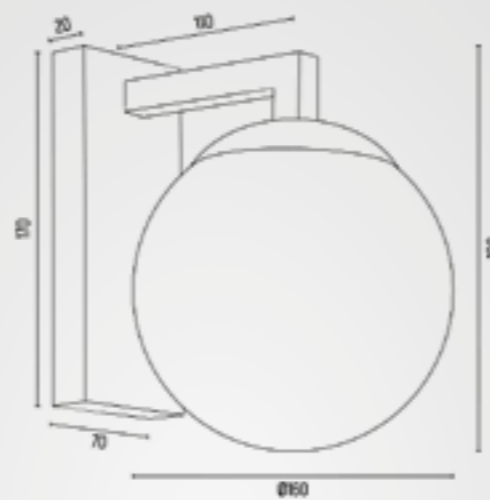

MORITZ 1743



MORITZ 4771



MORITZ

-  **4771** - opal mat, czarny struktura, el. mosiądzowany
-  kinkiet 1 pt.
-  szkło, stal lakierowana, stal mosiądzowana
-  E27 (nie zawiera źródła światła) / 230V | 1 x 15W (max)
-  190 wys. | 160 szer. | 200 g.
-  0,9
-  IP 20
-  możliwość zamontowania włącznika na przyścienniku



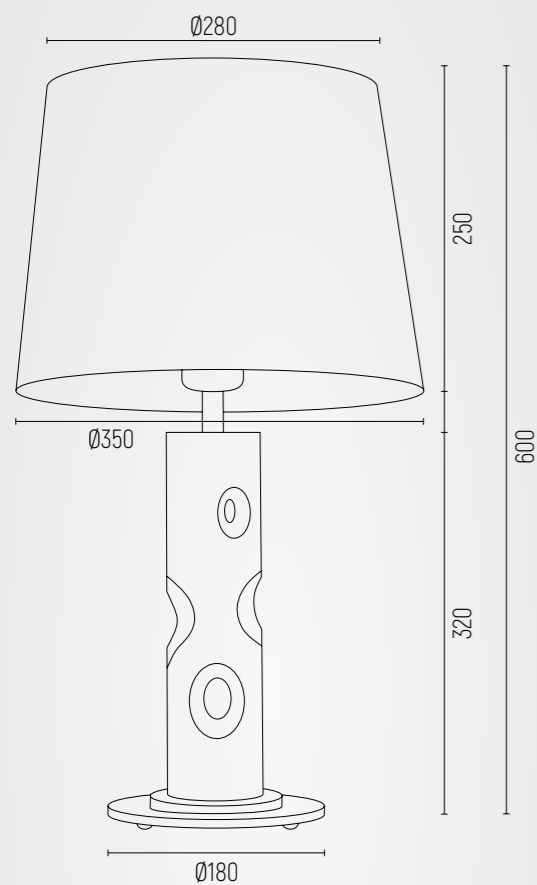









NANCY 3843



NANCY 3844

NANCY

-  **3843** - granat, transparentny, chrom
-  **3844** - błękitny, transparentny, chrom
-  lampa stołowa 1 pt.
-  **3843** - abażur welur, szkło, stal chromowana
3844 - abażur welur, szkło, stal chromowana
-  E27 (nie zawiera źródła światła) / 230V | 1 x 15W (max)
-  600 wys. | 350 szer. | 350 g.
-  3,6
-  IP 20



NEWA 3270



NEWA 3271



NEWA 3273



NEWA 3275













NEWA

-  **3270** - grafit
-  **3271** - morski
-  **3273** - słonkowy
-  **3275** - transparentny
-  lampa wisząca 1 pt.
-  szkło
-  E27 (nie zawiera źródła światła) / 230V | 1 x 15W (max)
-  1070 (przewód 800) wys. | 180 szer. | 180 g.
-  0,7
-  IP 20





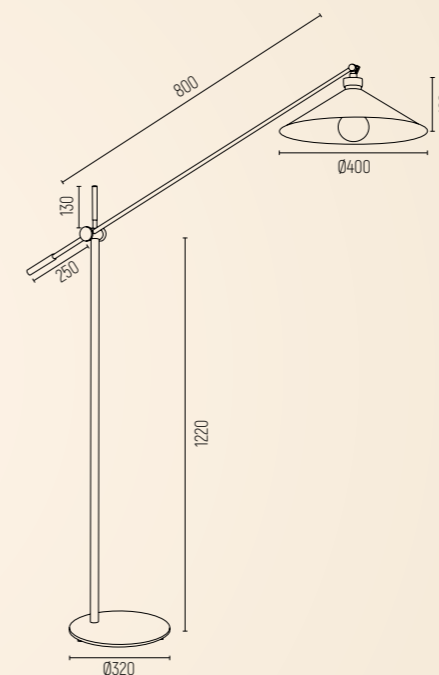
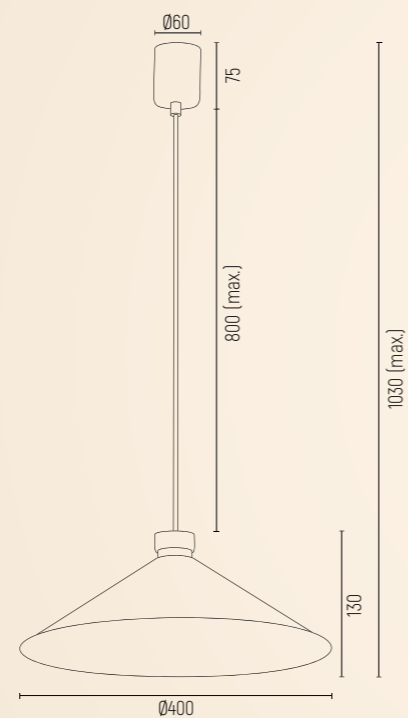

NASHVILLE





-  **4693** - biały struktura, el. mosiądzowane
-  **4694** - szalwia struktura, el. mosiądzowane
-  **4695** - czarny struktura, el. mosiądzowane
-  lampa wisząca 1 pt.
-  stal lakierowana, stal mosiądzowana
-  E27 (nie zawiera źródła światła) / 230V | 1 x 15W (max)
-  przewód max. 800, całość 1030 wys. | 400 szer. | 400 gt.
-  0,9
-  IP 20
-  możliwość zastosowania el. chromowanych lub lakierowanych zamiast el. mosiądzowanych







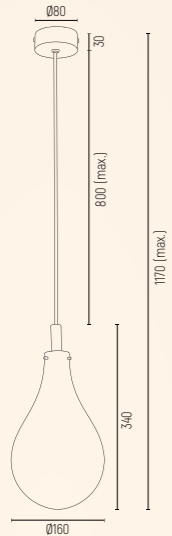

NASHVILLE

-  **4731** - biały struktura, el. mosiądzowane
-  **4733** - szalwia struktura, el. mosiądzowane
-  **4732** - czarny struktura, el. mosiądzowane
-  lampa podłogowa 1 pt.
-  stal lakierowana, stal mosiądzowana
-  E27 (nie zawiera źródła światła) / 230V | 1 x 15W (max)
-  max 2220 wys. | 400 szer. | max 1500 gt.
-  7,5
-  IP 20
-  możliwość regulacji, możliwość zastosowania el. chromowanych lub lakierowanych zamiast el. mosiądzowanych





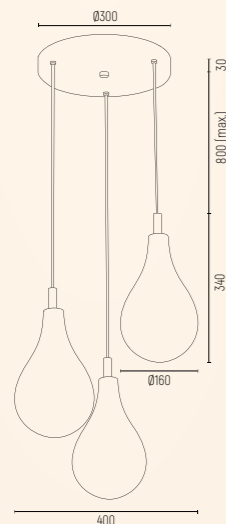

OAKLAND

-  **4696, 6104** - biały połysk, mosiądz
-  **4716, 6105** - dymny, czarny struktura
-  IP 20
-  możliwość zastosowania el. chromowanych lub lakierowanych zamiast el. mosiądzowanych



-  **4696, 4716** - lampa wisząca 1 pt.
-  szkło, stal mosiądzowana / stal lakierowana
-  G9 (nie zawiera źródła światła) / 230V | 1 x 6W LED
-  przewód max. 800, całość 1170 wys. | 160 szer. | 160 g.
-  1,1



-  **6104, 6105** - lampa wisząca 3 pt.
-  szkło, stal mosiądzowana / stal lakierowana
-  G9 (nie zawiera źródła światła) / 230V | 3 x 6W LED
-  przewód max 800, całość 1170 wys. | 400 szer. | 400 g.
-  3,3
-  możliwość modyfikacji na włączanie 1+2



OAKLAND 4696



OAKLAND 6104



OAKLAND 4716



OAKLAND 6105









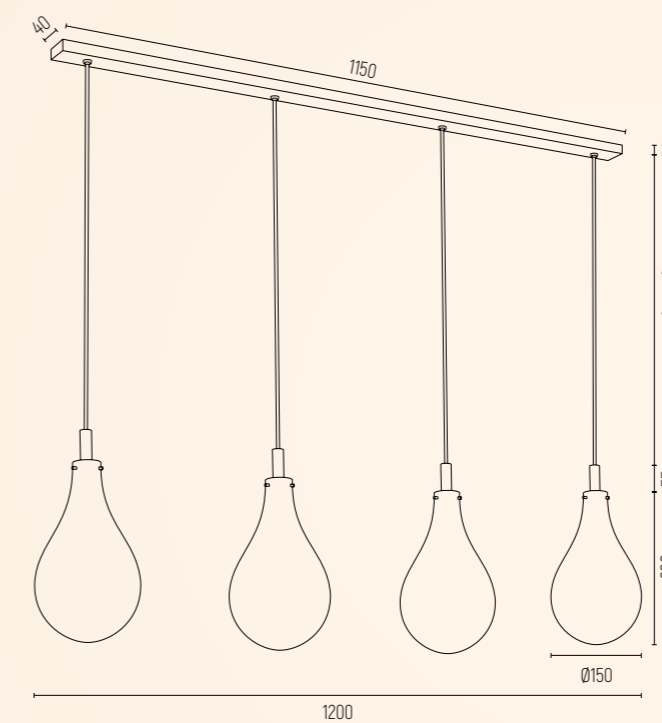

OAKLAND 1741



OAKLAND 1740



OAKLAND

-  **1741** - biały połysk, czarny struktura
-  **1740** - dymny, czarny struktura
-  lampa wisząca 4 pt.
-  szkło / stal lakierowana
-  G9 (nie zawiera źródła światła) / 230V | 4 x 6W LED (max)
-  przewód max 800, całość 1155 wys. | 1200 szer. | 150 g.
-  4,5
-  IP 20
-  możliwość modyfikacji na włączanie 2+2, możliwość zastosowania el. chromowanych lub lakierowanych zamiast el. mosiądzowanych

OREGON

- 3854, 3855, 3856 - biały struktura
- 3857, 3858, 3859 - złoty struktura
- 3860, 3861, 3862 - czarny struktura
- stal lakierowana
- IP 20
- możliwość zastosowania modułu LED o temperaturze barwowej 4000K - nieodpłatnie

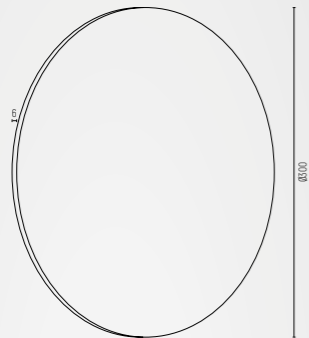

- 3854, 3857, 3860 - kinkiet 1 pt. L
- LED (zintegrowany) 230V / 540 lm / 3000 K | 1 x 6W
- 300 wys. | 300 szer. | 31 gt.
- 1,2

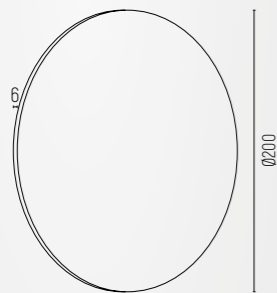

- 3855, 3858, 3861 - kinkiet 1 pt. M
- LED (zintegrowany) 230V / 404 lm / 3000 K | 1 x 4,5W
- 200 wys. | 200 szer. | 31 gt.
- 0,7

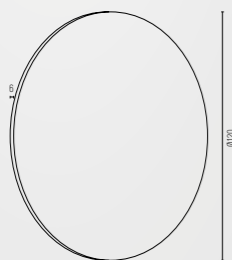

- 3856, 3859, 3862 - kinkiet 1 pt. S
- LED (zintegrowany) 230V / 270 lm / 3000 K | 1 x 3W
- 120 wys. | 120 szer. | 31 gt.
- 0,3



OREGON 3854, 3855, 3856



OREGON 3857, 3858, 3859



OREGON 3860, 3861, 3862



OPTICA 2529



OPTICA 2530

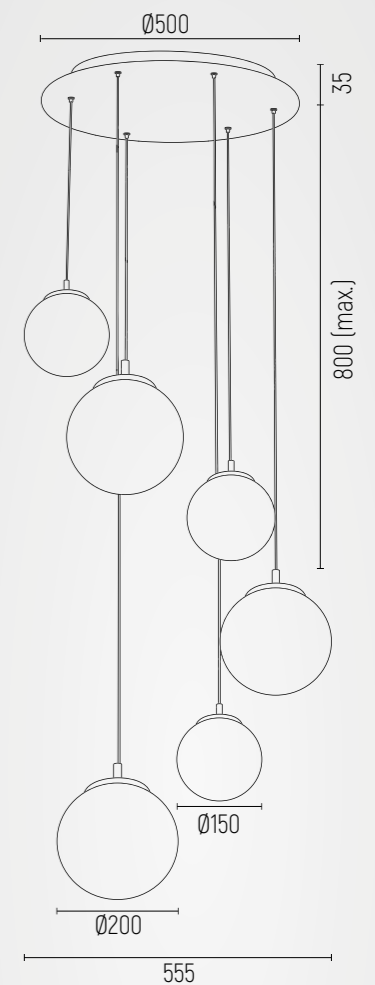

OPTICA

- 2529 - lister grafit, chrom
- 2530 - opal, chrom
- lampa wisząca 6 pt. na okrągłej podsufitce
- szkło, stal chromowana
- E27 (nie zawiera źródła światła) / 230V | 6 x 15W (max)
- 1700 wys. | 555 szer. | 555 gt.
- 5,3
- IP 20
- możliwość zastosowania modyfikacji na włączenie 2+4, 3+3, możliwość zastosowania stali lakierowanej / mosiądzowanej zamiast stali chromowanej lub el. lakierowanych / mosiądzowanych zamiast chromowanych

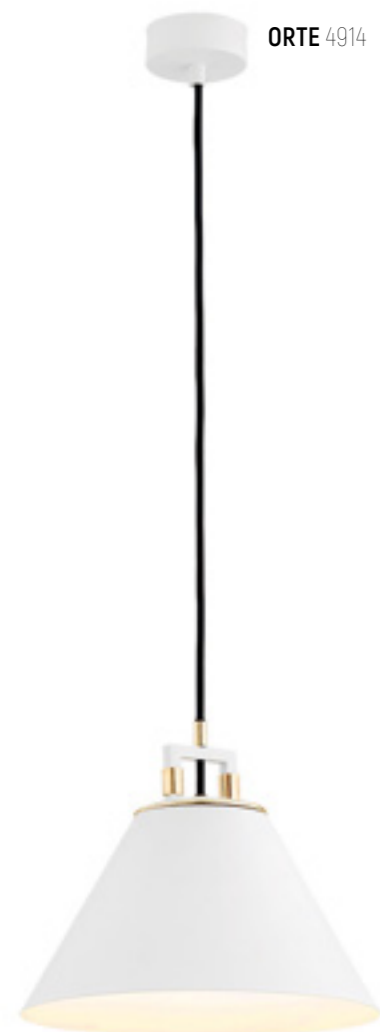

ORTE 4914

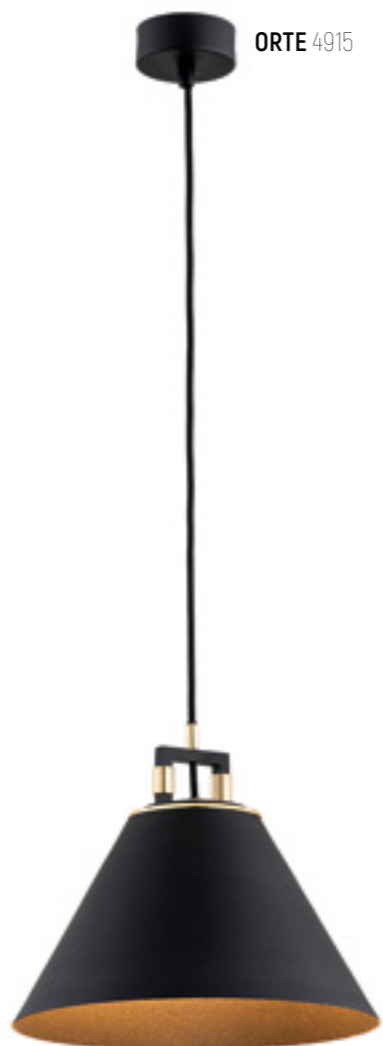

ORTE 4915



ORTE 4916



ORTE 6173









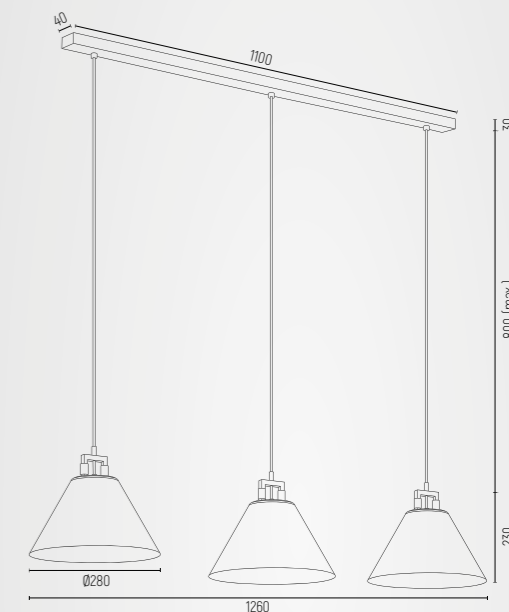



ORTE 6174



ORTE 6177



ORTE

-  4914 - biały struktura, el. mosiądzowane
-  4915 - czarny struktura, el. mosiądzowane
-  4916 - szalwia struktura, el. mosiądzowane
-  lampa wisząca 1 pt.
-  stal lakierowana, stal mosiądzowana
-  E27 (nie zawiera źródła światła) / 230V | 1 x 15W (max)
-  1050 wys. | 280 szer. | 280 gł.
-  1
-  IP 20
-  możliwość zastosowania el. chromowanych lub lakierowanych zamiast el. mosiądzowanych

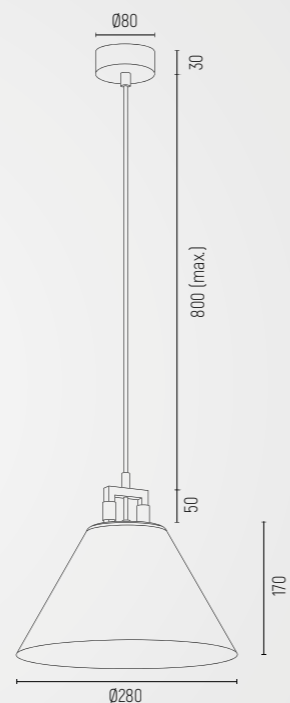

ORTE





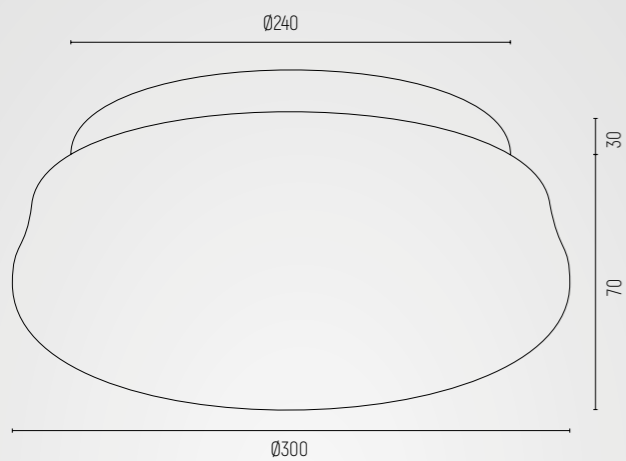

-  6173 - biały struktura, el. mosiądzowane
-  6174 - czarny struktura, el. mosiądzowane
-  6177 - szalwia struktura, el. mosiądzowane
-  lampa wisząca 3 pt.
-  stal lakierowana, stal mosiądzowana
-  E27 (nie zawiera źródła światła) / 230V | 3 x 15W (max)
-  1060 wys. | 1260 szer. | 280 gł.
-  3,2
-  IP 20
-  możliwość modyfikacji na włączanie 1+2, możliwość zastosowania el. chromowanych lub lakierowanych zamiast el. mosiądzowanych



OMBRA 6142







OMBRA

-  **6142** - opal mat, msiądz
-  plafon 3 pt.
-  szkło, stal msiądzowana
-  E27 (nie zawiera źródła światła) / 230V | 3 x 15W (max)
-  100 wys. | 300 szer. | 300 g.
-  1,2
-  IP 20





SALADO 670 | 1199

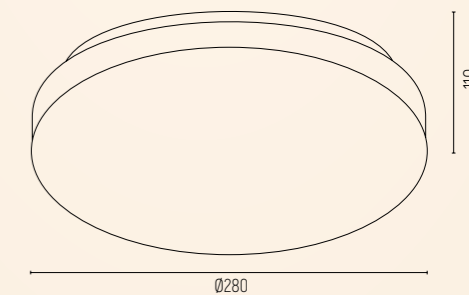

SALADO

-  opal mat, chrom
-  szkło, stal chromowana
-  E27 (nie zawiera źródła światła) / 230V | 3 x 15W (max)
-  IP 20

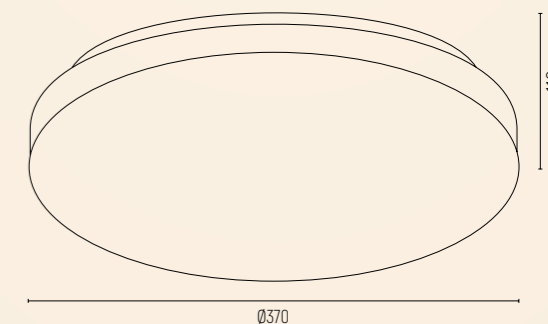

-  **670** - plafon 3 pt.
-  110 wys. | 280 szer. | 280 g.
-  2



-  **1199** - plafon 3 pt.
-  110 wys. | 370 szer. | 370 g.
-  2,8



GIN 3224



GIN 694



CHICAGO 1030

GIN

3224, 694 - opal mat

szkło

IP 20

3224 - plafon 3 pt.

E27 (nie zawiera źródła światła) / 230V | 3 x 15W (max)

70 wys. | 400 szer. | 400 gt.

2,1

694 - plafon 2 pt.

E27 (nie zawiera źródła światła) / 230V | 2 x 15W (max)

70 wys. | 300 szer. | 300 gt.

1,5

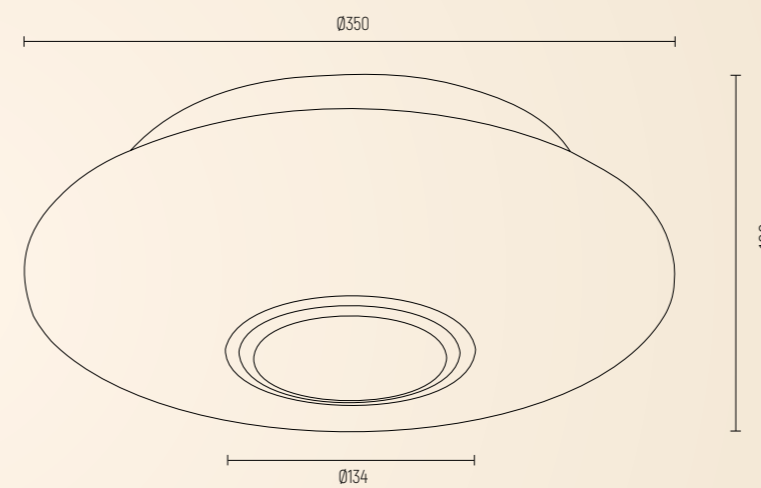
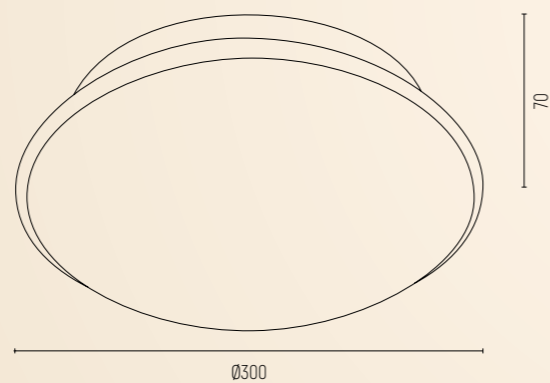
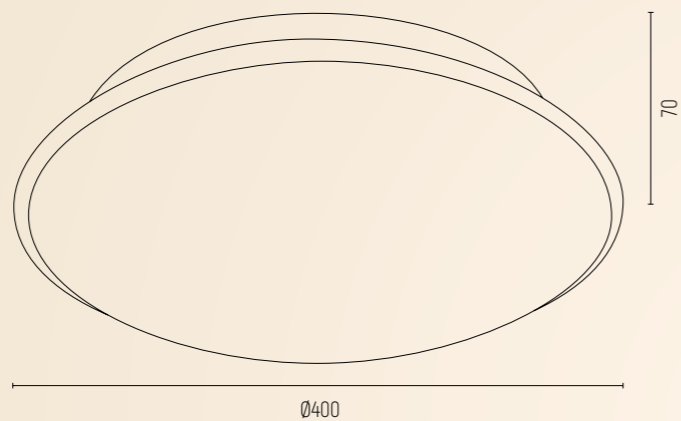

CHICAGO

1030 - opal mat, el. mosiądzowany

plafon 2 pt.

szkło, stal mosiądzowana

E27 (nie zawiera źródła światła) / 230V | 2 x 15W (max)







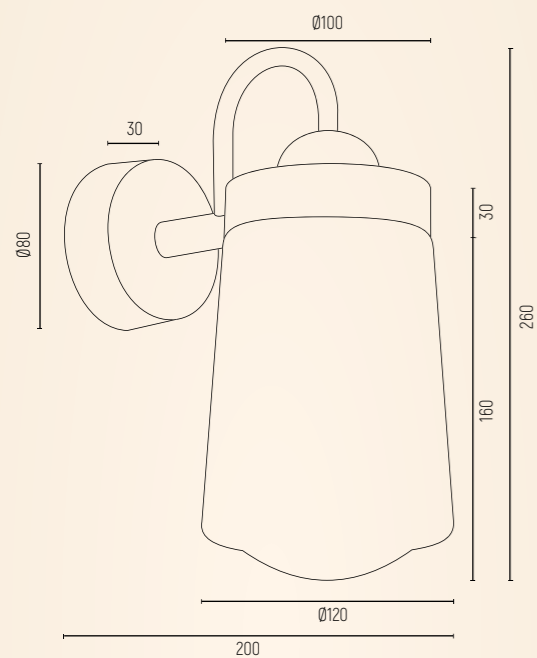



100 wys. | 350 szer. | 350 gt.

2

IP 20



PASADENA

-  **4717** – biały połysk, mosiądz
-  **4718** – dymny, chrom
-  **4719** – transparentny, chrom
-  kinkiet 1 pt.
-  **4717** – szkło, stal mosiądzowana
4718, 4719 – szkło, stal chromowana
-  E27 (nie zawiera źródła światła) / 230V | 1 x 15W (max)
-  260 wys. | 120 szer. | 200 gł.
-  0,9
-  IP44
-  możliwość zamontowania włącznika na przycienniku



PASADENA 4717



PASADENA 4718



PASADENA 4719







PASADENA 8004







PASADENA 8005

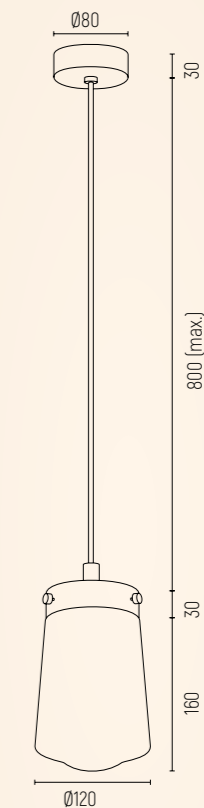



PASADENA

-  biały połysk, mosiądz
-  szkło, stal mosiądzowana
-  E27 (nie zawiera źródła światła) / 230V | 1 x 15W (max)
-  możliwość zastosowania el. chromowanych lub lakierowanych zamiast el. mosiądzowanych

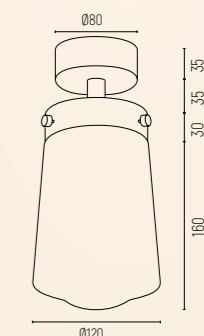





-  **8004** – lampa wisząca 1 pt.
-  1020 wys. | 120 szer. | 120 gł.
-  0,6
-  IP 20







-  **8005** – plafon 1 pt.
-  260 wys. | 120 szer. | 120 gł.
-  0,6
-  IP 44

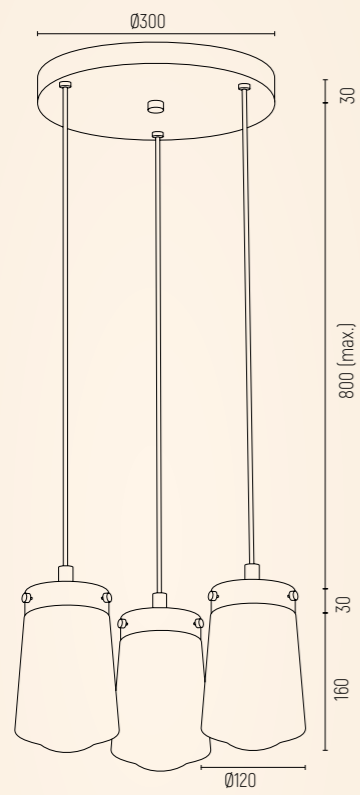



PASADENA

-  biały połysk, mosiądz
-  szkło, stal mosiądzowana
-  E27 (nie zawiera źródła światła) / 230V | 3 x 15W (max)
-  możliwość modyfikacji na włączenie 1+2, możliwość zastosowania el. chromowanych lub lakierowanych zamiast el. mosiądzowanych

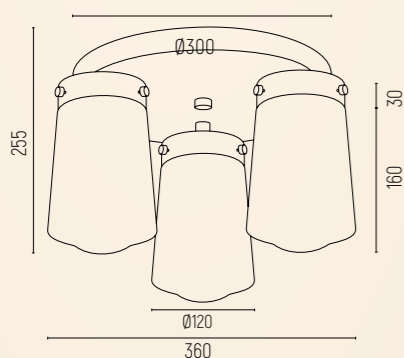

-  **6164** - lampa wisząca 3 pt.
-  1020 wys. | 360 szer. | 360 gt.
-  2
-  IP 20



-  **6165** - plafon 3 pt.
-  255 wys. | 360 szer. | 360 gt.
-  2
-  IP 44

PASADENA 6164

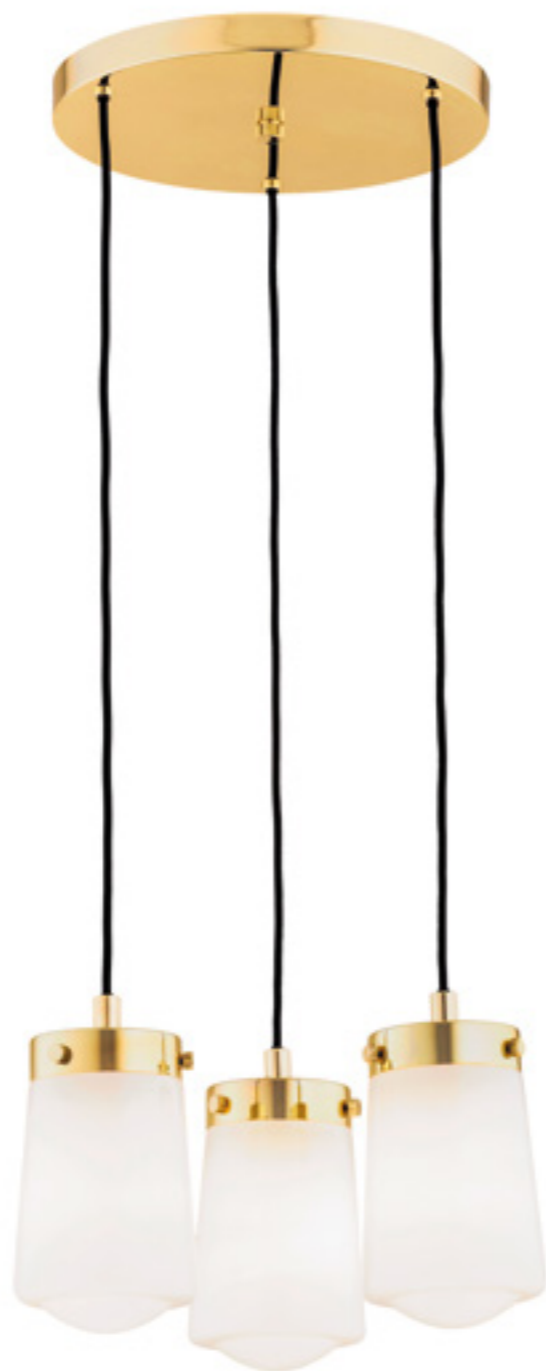

PASADENA 6165







PASADENA 1772







PASADENA 2550





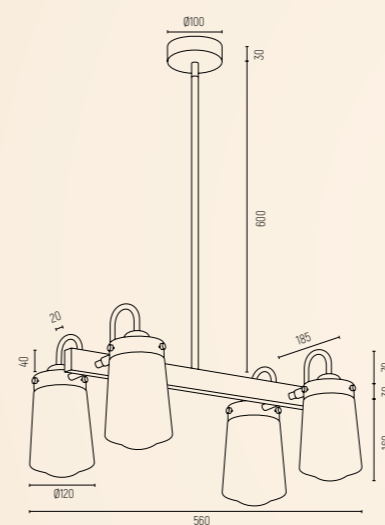

PASADENA

-  biały połysk, mosiądz
-  szkło, stal mosiądzowana
-  IP 20
-  możliwość zastosowania el. chromowanych lub lakierowanych zamiast el. mosiądzowanych

-  **1772** - żyrandol 4 pt.
-  E27 (nie zawiera źródła światła) / 230V | 4 x 15W (max)
-  820 wys. | 560 szer. | 410 gt.
-  4
-  możliwość modyfikacji na włączenie 2+2



-  **2550** - żyrandol 6 pt.
-  E27 (nie zawiera źródła światła) / 230V | 6 x 15W (max)
-  820 wys. | 850 szer. | 410 gt.
-  5,2
-  możliwość modyfikacji na włączenie 2+4 lub 3+3

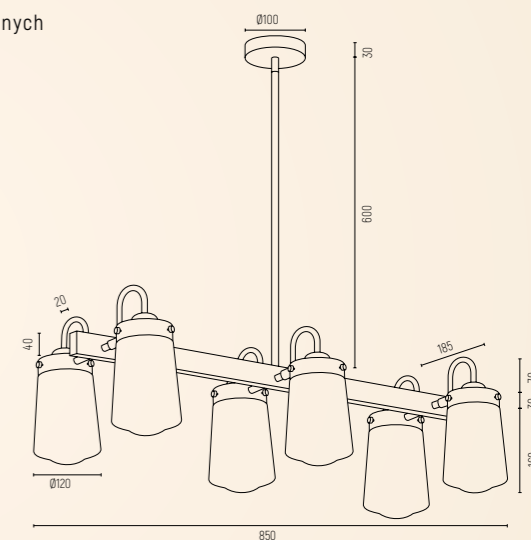



POLONIA

 7042 - opal, czerwony

 6176 - biały, opal, czerwony

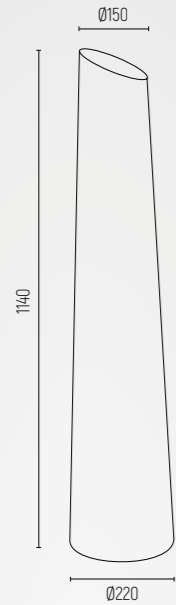
 IP20



 7042 - lampa-wazon podłogowa 2 pt.

 szkło

 E27 (nie zawiera źródła światła) / 230V | 2 x 15W (max)

 1140 wys. | 220 szer. | 220 gt.

 7,8

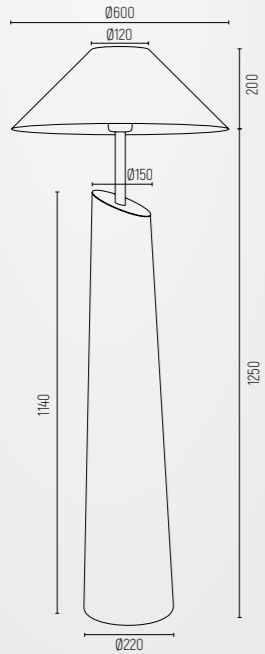

 6176 - lampa podłogowa 3 pt.

 abażur, szkło

 E27 (nie zawiera źródła światła) / 230V | 3 x 15W (max)

 1450 wys. | 600 szer. | 600 gt.

 8,3



POLONIA 7042

POLONIA 6176





PONTE PLUS 4728



PONTE 4347



PONTE PLUS 4727



PONTE 4348



PONTE PLUS 4729



PONTE 4349



PONTE PLUS 8105

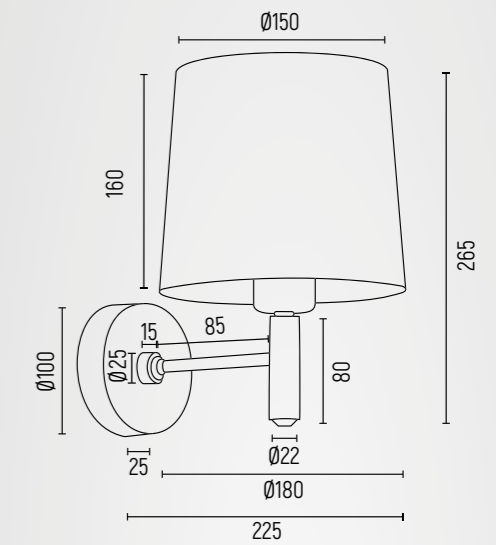

PONTE PLUS PONTE

-  4728 - śmietankowy, ciemny mosiądz
-  4727 - beżowy, ciemny mosiądz
-  4729 - czarny, ciemny mosiądz
-  4347 - błękit, ciemny mosiądz
-  4348 - granat, ciemny mosiądz
-  4349 - różowy, ciemny mosiądz
-  8105 - zielony, ciemny mosiądz
-  kinkiet 1 pt.
-  abażur welur, stal mosiężowana
-  E27 (nie zawiera źródła światła) / 230V | 1 x 15W (max)
-  265 wys. | 180 szer. | 225 g.
-  0,8
-  IP 20
-  możliwość zamontowania włącznika na przyścienniku

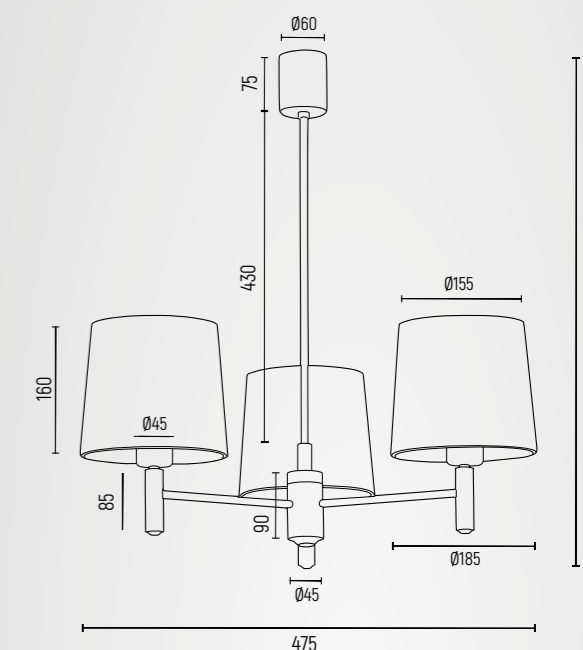

PONTE PLUS PONTE

-  6110 – śmietankowy, ciemny mosiądz
-  6109 – beżowy, ciemny mosiądz
-  6111 – czarny, ciemny mosiądz
-  1484 – błękit, ciemny mosiądz
-  1485 – granat, ciemny mosiądz
-  1498 – różowy, ciemny mosiądz
-  6192 – zielony, ciemny mosiądz
-  żyrandol 3 pt.
-  abażur welur, stal mosiądzowana
-  E27 (nie zawiera źródła światła) / 230V | 3 x 15W (max)
-  630 wys. | 475 szer. | 475 gł.
-  2,6
-  IP 20
-  możliwość modyfikacji - włączanie 1+2



PONTE PLUS 2106



PONTE PLUS 2105



PONTE PLUS 2107



PONTE PLUS 2145



PONTE 2085



PONTE 2086







PONTE 2089

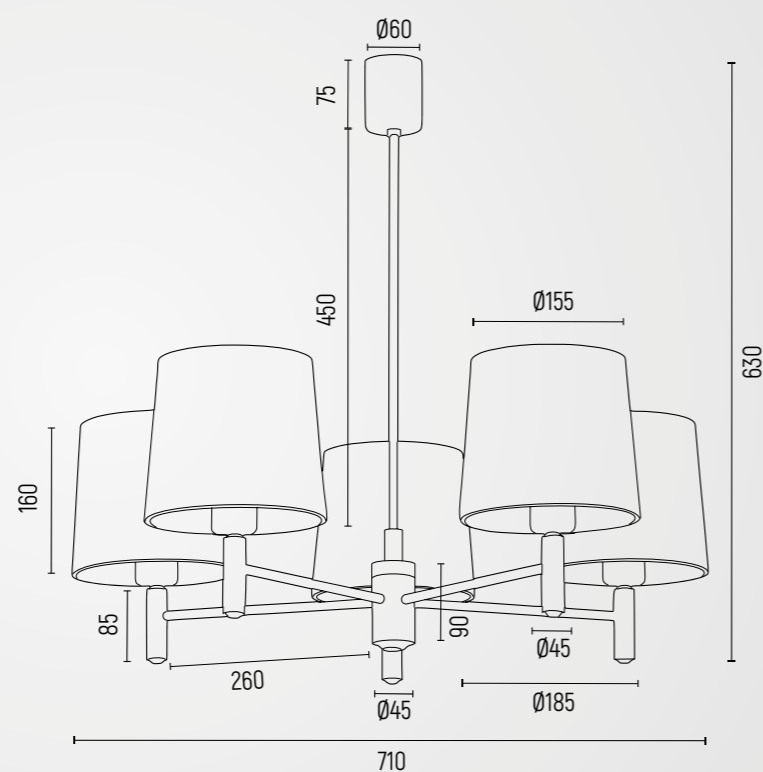



PONTE PLUS PONTE





-  2106 - śmietankowy, ciemny mosiądz
-  2105 - beżowy, ciemny mosiądz
-  2107 - czarny, ciemny mosiądz
-  2085 - błękit, ciemny mosiądz
-  2086 - granat, ciemny mosiądz
-  2089 - różowy, ciemny mosiądz
-  2145 - zielony, ciemny mosiądz
-  żyrandol 5 pł.
-  abażur welur, stal mosiądzowana
-  E27 (nie zawiera źródła światła) / 230V | 5 x 15W (max)
-  630 wys. | 710 szer. | 710 gł.
-  3,4
-  IP 20
-  możliwość modyfikacji na włączenie 3+2













PORTORYKO





-  jasny brąz, chrom
-  drewno, stal chromowana
-  IP 20
-  możliwość zastosowania stali lakierowanej i el. lakierowanych zamiast stali chromowanej

-  **3598** - kinkiet 1 pt.
-  E14 (nie zawiera źródła światła) / 230V | 1 x 7W (max)
-  220 wys. | 170 szer. | 300 g.
-  0,4
-  możliwość zamontowania włącznika na przyścienniku

-  **771** - plafon 2 pt.
-  E14 (nie zawiera źródła światła) / 230V | 2 x 7W (max)
-  220 wys. | 460 szer. | 170 g.
-  0,7

-  **1306** - plafon 3 pt.
-  E14 (nie zawiera źródła światła) / 230V | 3 x 7W (max)
-  220 wys. | 820 szer. | 170 g.
-  1,1
-  możliwość modyfikacji na włączanie 1+2

-  **1336** - lampa wisząca 3 pt.
-  E14 (nie zawiera źródła światła) / 230V | 3 x 7W (max)
-  1000 (przewód 800) wys. | 830 szer. | 170 g.
-  1,28
-  możliwość modyfikacji na włączanie 1+2

-  **3678** - lampa wisząca 1 pt.
-  E14 (nie zawiera źródła światła) / 230V | 1 x 7W (max)
-  1030 (przewód 800) wys. | 170 szer. | 170 g.
-  0,4

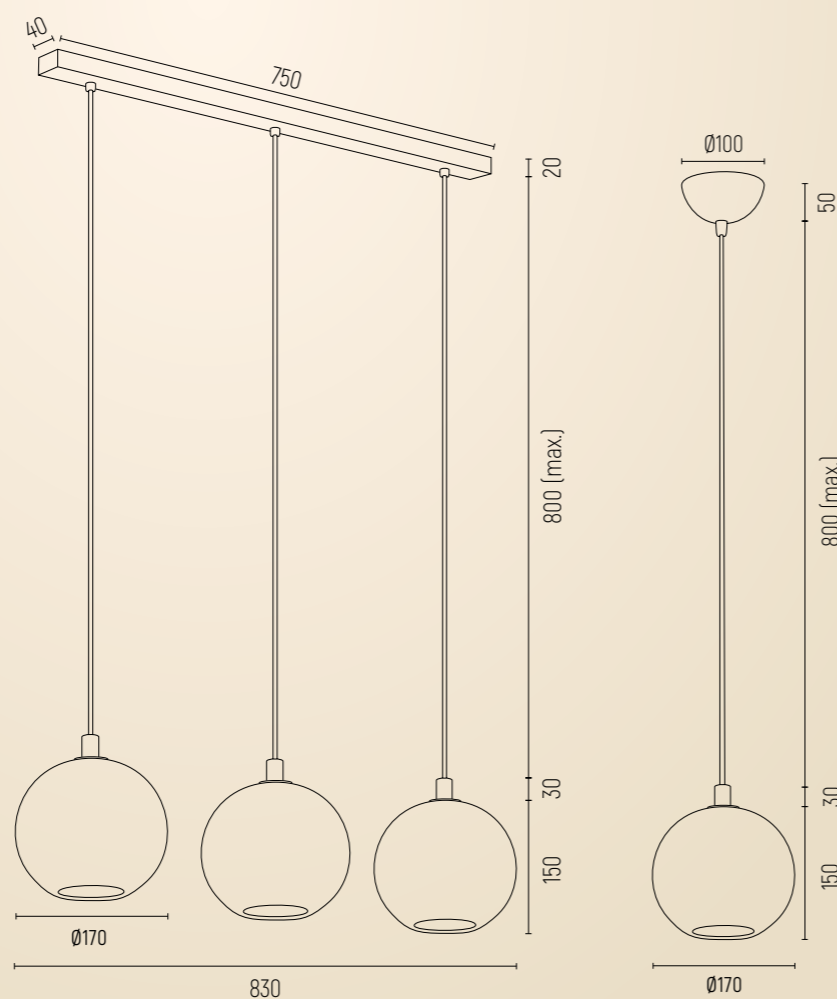
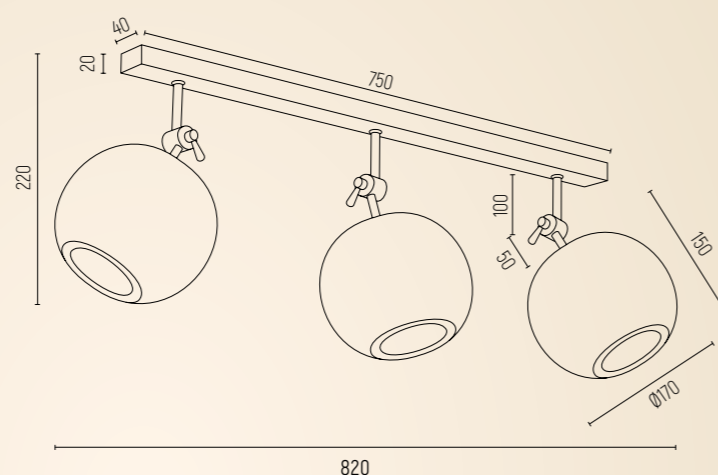
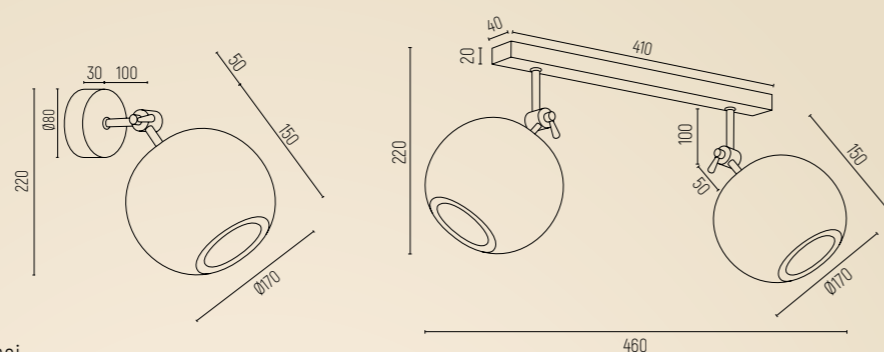

PORTORYKO 3598



PORTORYKO 771



PORTORYKO 1306



PORTORYKO 1336

PORTORYKO 3678

PORTORYKO 3673



PORTORYKO 3667



PORTORYKO 3672



TWIST 4899



TWIST 4900







TWIST 7036









TWIST 7037

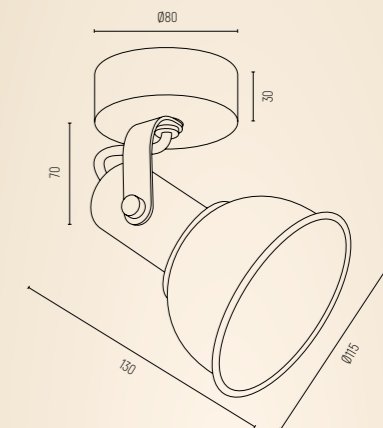





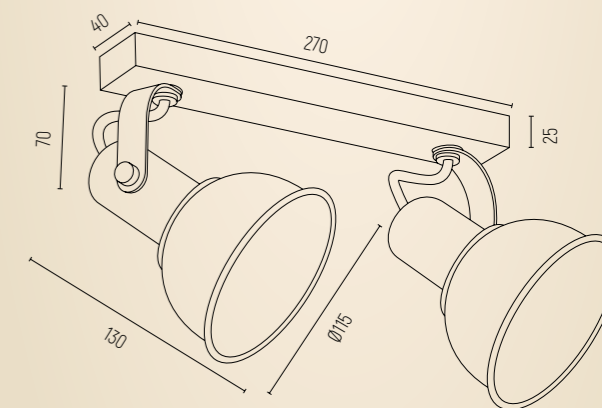

TWIST

-  4899, 7036 – biały struktura, el. mosiężowane
-  4900, 7037 – czarny struktura, el. mosiężowane
-  stal lakierowana, stal mosiężowana
-  IP 20











-  4899, 4900 – kinkiet 1 pt.
-  E14 (nie zawiera źródła światła) / 230V | 1 x 7W (max)
-  max 180 wys. | 115 szer. | max 140 gł.
-  0,35
-  możliwość regulacji, możliwość zamontowania włącznika na przycienniku









-  7036, 7037 – plafon 2 pt.
-  E14 (nie zawiera źródła światła) / 230V | 2 x 7W (max)
-  max 170 wys. | max 340 szer. | max 140 gł.
-  0,75
-  możliwość regulacji

PORTORYKO

-  jasny brąz, chrom
-  drewno, stal chromowana
-  IP 20
-  E27 (nie zawiera źródła światła) / 230V | 1 x 15W (max)
-  możliwość zastosowania stali lakierowanej i el. lakierowanych zamiast stali chromowanej



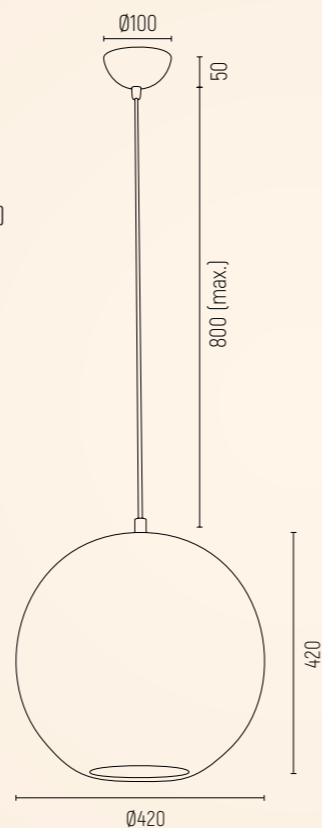
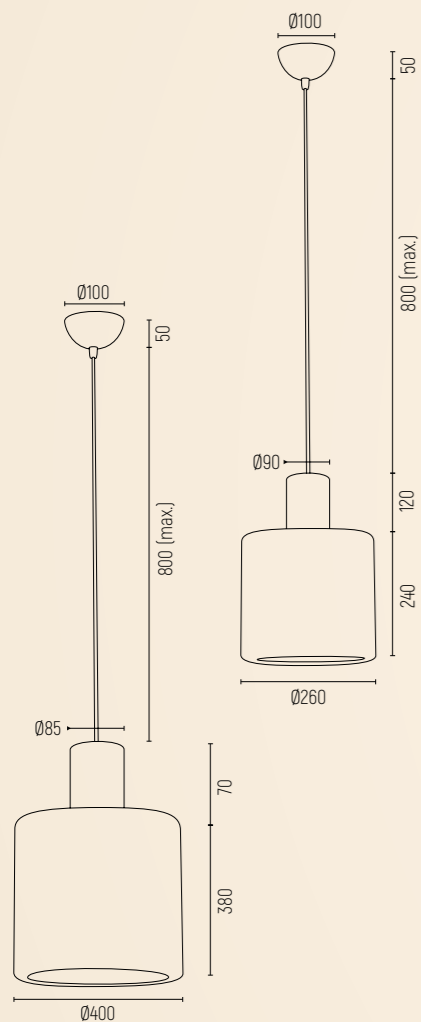

-  3673 – lampa wisząca 1 pt. duży walec
-  1300 (przewód 800) wys. | 400 szer. | 400 gł.
-  1,1

-  3667 – lampa wisząca 1 pt. mniejszy walec
-  1210 (przewód 800) wys. | 260 szer. | 260 gł.
-  1





-  3672 – lampa wisząca 1 pt. kula
-  1270 (przewód 800) wys. | 420 szer. | 420 gł.
-  1,3



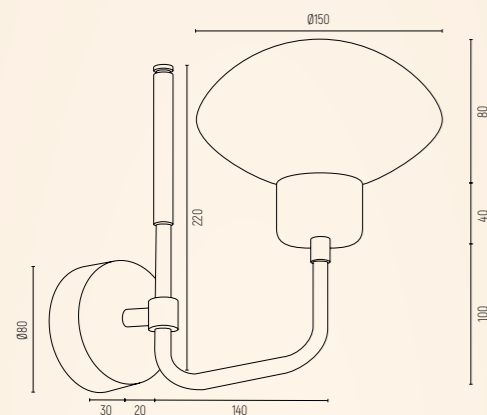



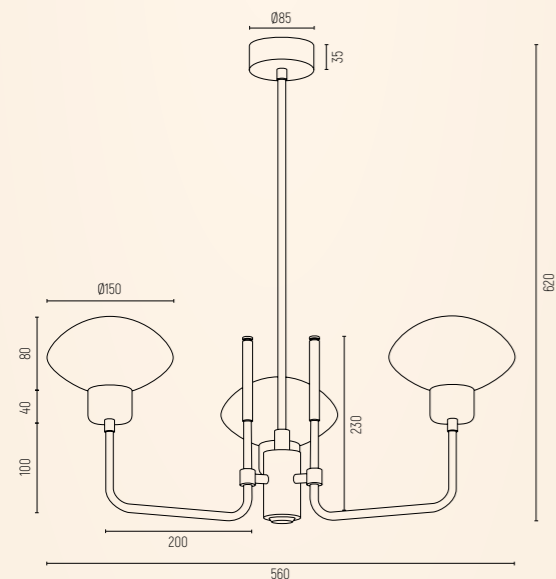

RAVELLO

-  opal mat, czarny struktura, mosiądz
-  szkło, stal lakierowana, stal mosiądzowana
-  IP 20
-  możliwość zastosowania el. chromowanych lub lakierowanych zamiast el. mosiądzowanych









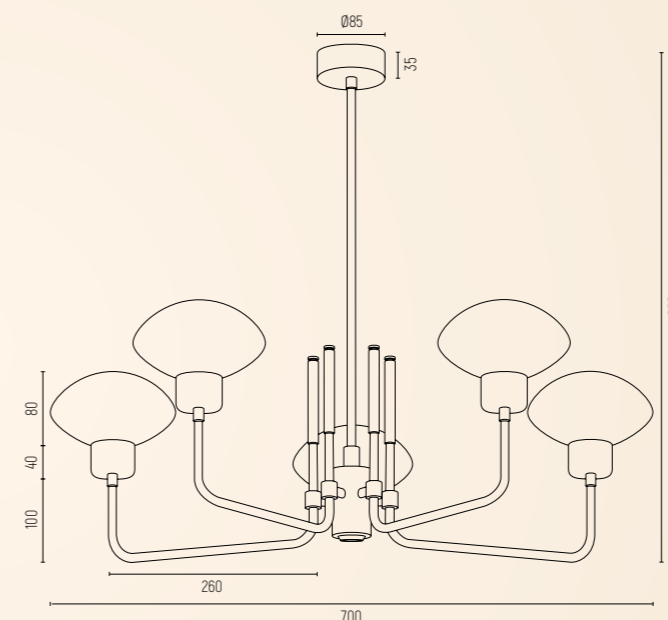

-  **8032** - kinkiet 1 pt.
-  E27 (nie zawiera źródła światła) / 230V | 1 x 15W (max)
-  220 wys. | 150 szer. | 260 gł.
-  0,5
-  możliwość zamontowania włącznika na przyścienniku



-  **6166** - żyrandol 3 pt.
-  E27 (nie zawiera źródła światła) / 230V | 3 x 15W (max)
-  620 wys. | 560 szer. | 560 gł.
-  2,4
-  możliwość modyfikacji na włączanie 1+2



RAVELLO

-  **2128** - opal mat, czarny struktura, mosiądz
-  żyrandol 5 pt.
-  szkło, stal lakierowana, stal mosiądzowana
-  E27 (nie zawiera źródła światła) / 230V | 5 x 15W (max)
-  620 wys. | 700 szer. | 700 gł.
-  3,5
-  IP 20
-  możliwość modyfikacji na włączanie 2+3, możliwość zastosowania el. chromowanych lub lakierowanych zamiast el. mosiądzowanych









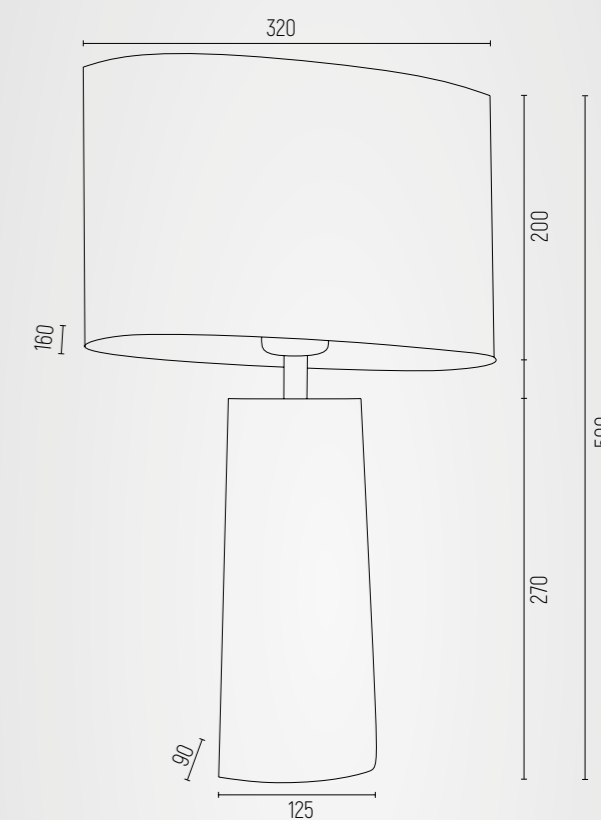

PRATO 3841



PRATO 3842









PRATO

-  **3841** - różowy, transparentny, chrom
-  **3842** - turkus, lister miodowy, chrom
-  lampa stołowa 1 pt.
-  abażur zamsz, szkło, stal chromowana
-  E27 (nie zawiera źródła światła) / 230V | 1 x 15W (max)
-  500 wys. | 320 szer. | 160 gł.
-  2,5
-  IP 20
-  możliwość zastosowania el. mosiądzowanych lub lakierowanych zamiast el. chromowanych





SAGUNTO

-  opal mat, mosiądz
-  lampa wisząca 1 pt.
-  szkło, stal mosiądzowana
-  E27 (nie zawiera źródła światła) / 230V | 1 x 15W (max)
-  IP 20
-  możliwość zastosowania stali lakierowanej lub chromowanej zamiast stali mosiądzowanej

 **4356** - przewód max. 800, całość 1200 wys. | 140 szer. | 140 gt.

 0,7

 klosz podłużny

 **4357** - przewód max. 800, całość 1100 wys. | 200 szer. | 200 gt.

 0,5

 klosz okrągły



 **4358** - przewód max. 800, całość 1040 wys. | 300 szer. | 300 gt.

 0,8

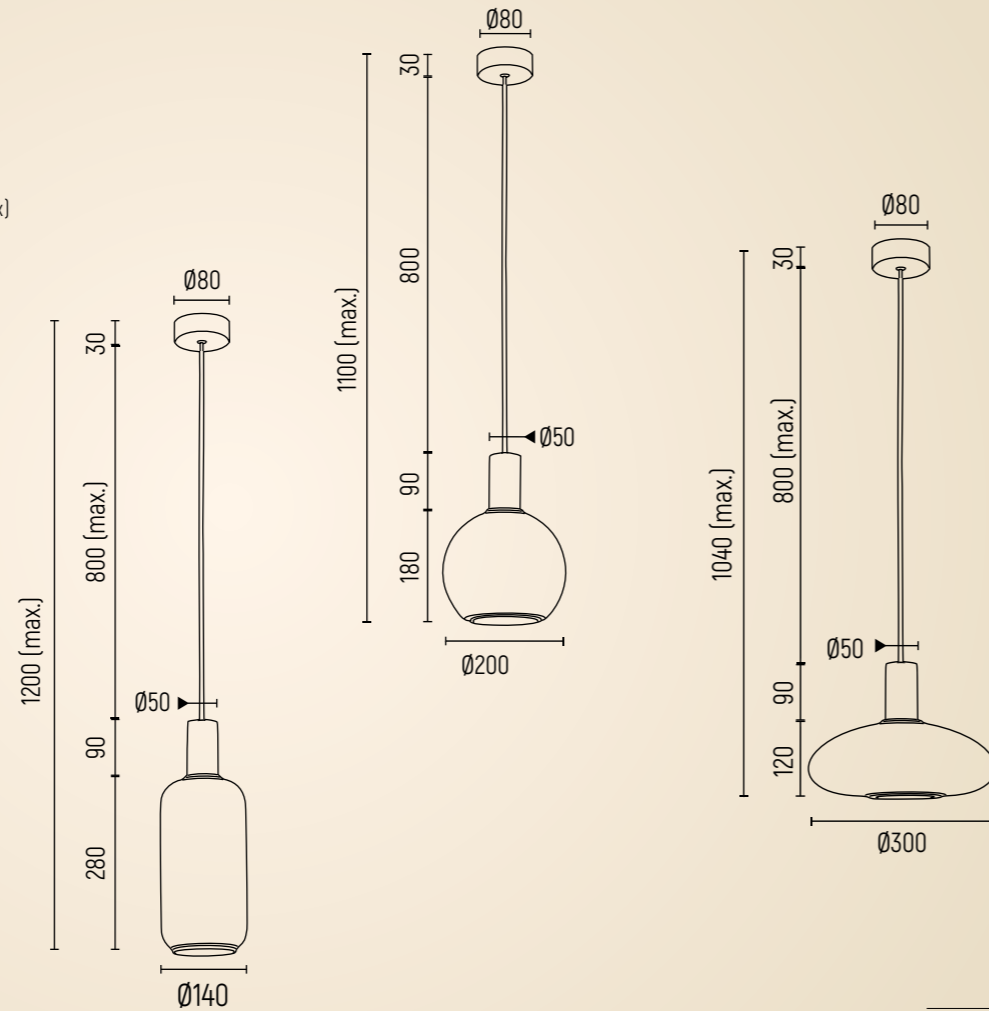



 klosz spodek



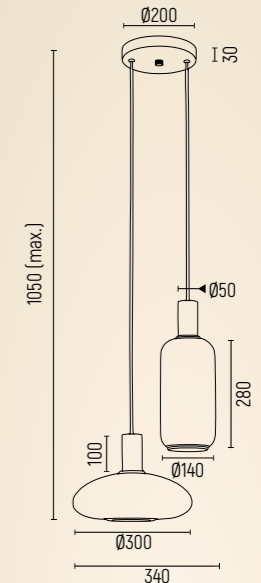



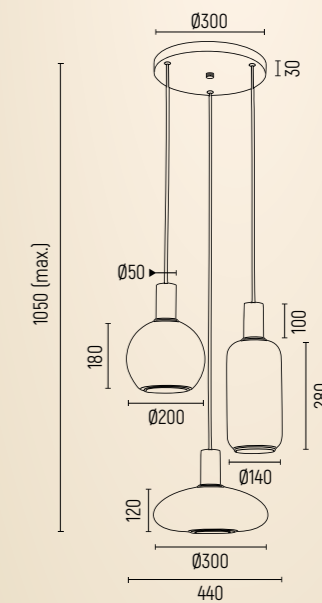

SAGUNTO

-  opal mat, mosiądz
-  szkło, stal mosiądzowana
-  IP 20



-  **896** - lampa wisząca 2 pt. na okrągłej podsufitce
-  E27 (nie zawiera źródła światła) / 230V | 2 x 15W (max)
-  przewód max. 800, całość 1050 wys. | 340 szer. | 300 gt.
-  2
-  możliwość modyfikacji na włączanie 1+1



-  **1489** - lampa wisząca 3 pt. na okrągłej podsufitce
-  E27 (nie zawiera źródła światła) / 230V | 3 x 15W (max)
-  przewód max. 800, całość 1050 wys. | 440 szer. | 440 gt.
-  3
-  możliwość modyfikacji na włączanie 1+2











RENO 1033



RENO 1034

RENO

-  **1033** - opal mat, chrom
-  **1034** - opal mat, msiądz
-  kinkiet 2 pt.
-  **1033** - szkło, stal chromowana
1034 - szkło, stal msiądzowana
-  E14 (nie zawiera źródła światła) / 230V | 2 x 7W (max)
-  340 wys. | 135 szer. | 150 g.
-  0,9
-  IP 20
-  możliwość zamontowania również "odwrotnie"/
możliwość zamontowania włącznika na przycienniku

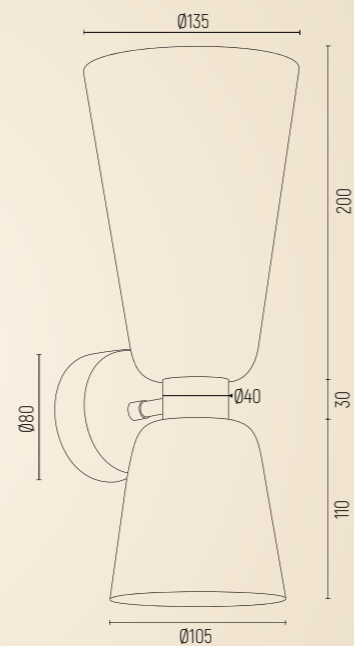

SANDRINO PLUS 6197



SANDRINO PLUS 6198







SANDRINO PLUS 5056







SANDRINO PLUS 5057

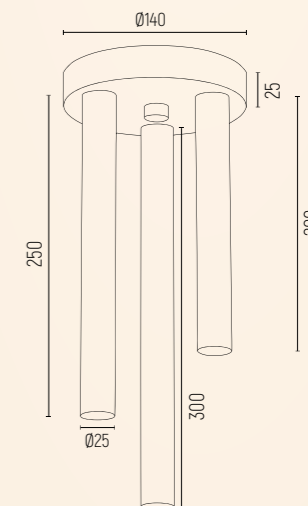



SANDRINO PLUS

-  **6197, 5056** - msiądz
-  **6198, 5057** - chrom
-  **6197, 5056** - stal msiądzowana
6198, 5057 - stal chromowana
-  IP 20

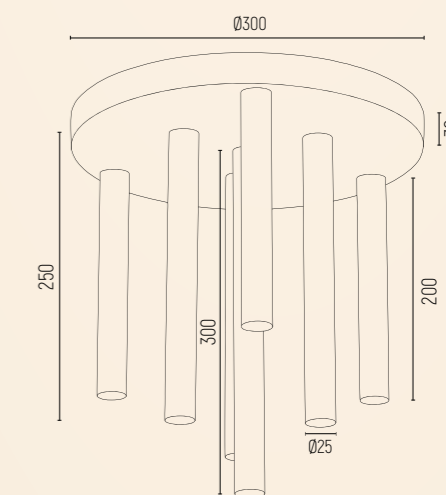







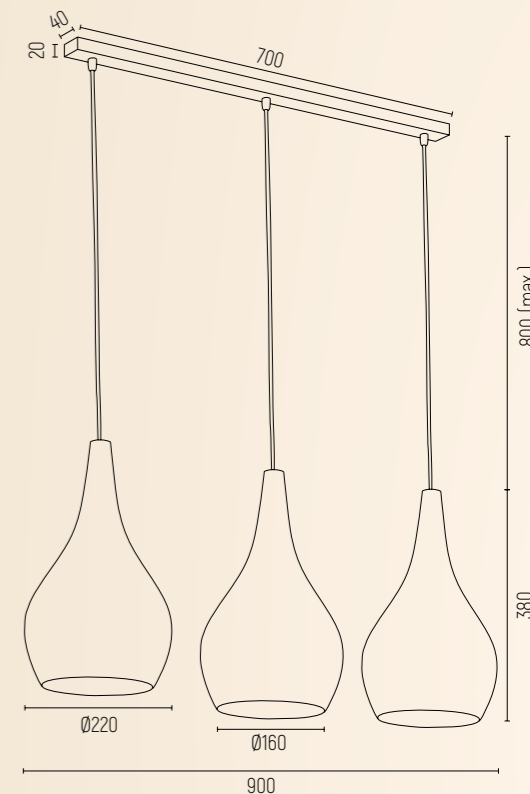



-  **6197, 6198** - plafon 3 pt.
-  G9 (nie zawiera źródła światła) / 230V | 3 x 6W (max)
-  330 wys. | 140 szer. | 140 g.
-  0,6



-  **5056, 5057** - plafon 7 pt.
-  G9 (nie zawiera źródła światła) / 230V | 7 x 6W (max)
-  330 wys. | 300 szer. | 300 g.
-  1,2



SANTANA

-  **4045** - transparentny, mosiądz
-  **3996** - opal, biały połysk
-  **3997** - czarny, czarny połysk
-  lampa wisząca 1 pt.
-  **4045** - szkło, stal mosiądzowana
-  **3996, 3997** - szkło, stal lakierowana
-  E27 (nie zawiera źródła światła) / 230V | 1 x 15W (max)
-  1200 (przewód 800) wys. | 220 szer. | 220 gł.
-  1,5
-  IP 20

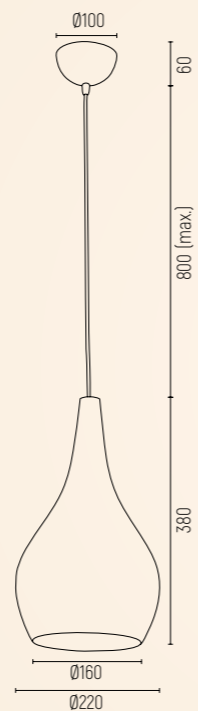

SANTANA





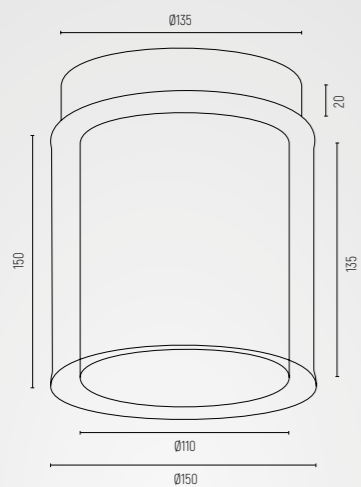

-  **1444** - transparentny, mosiądz
-  **1408** - opal, biały połysk
-  **1409** - czarny, czarny połysk
-  lampa wisząca 3 pt.
-  **4045** - szkło, stal mosiądzowana
-  **3996, 3997** - szkło, stal lakierowana
-  E27 (nie zawiera źródła światła) / 230V | 3 x 15W (max)
-  1200 (przewód 800) wys. | 900 szer. | 220 gł.
-  4,3
-  IP 20
-  możliwość modyfikacji na włączenie 1+2



URAL 3173



URAL





-  3173 – szkło transparentne na zewnątrz, szkło opal mat wewnątrz
-  plafon 1 pt.
-  szkło, stal chromowana
-  E27 (nie zawiera źródła światła) / 230V | 1 x 15W (max)
-  170 wys. | 150 szer. | 150 g.
-  0,9
-  IP 20

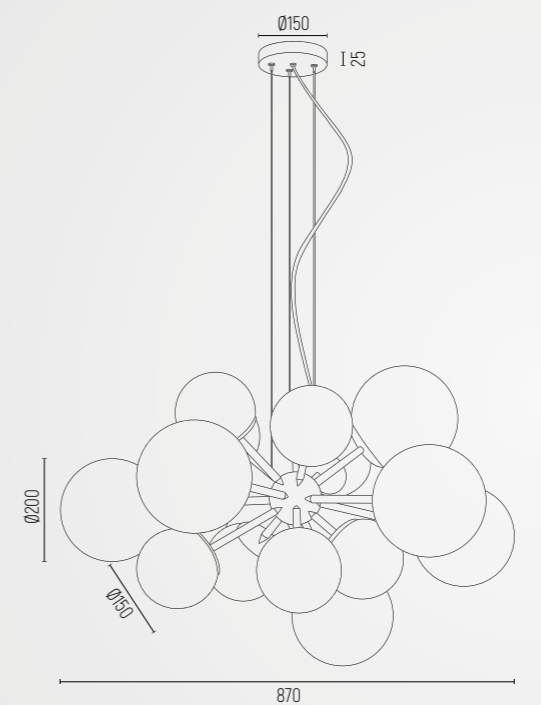

SATELITE PLUS 5048



SATELITE PLUS

-  5048 – opal mat, mosiądz
-  żyrandol 15 pt.
-  szkło, stal mosiądzowana
-  E27 (nie zawiera źródła światła) / 230V | 15 x 15W (max)
-  1500 wys. | 870 szer. | 870 g.
-  7,5
-  IP 20

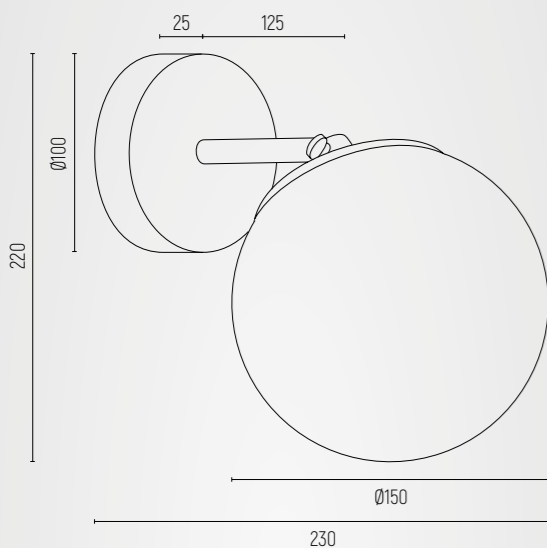

SATELITE PLUS 4744

SATELITE PLUS 1052



SATELITE 3988



SATELITE 840

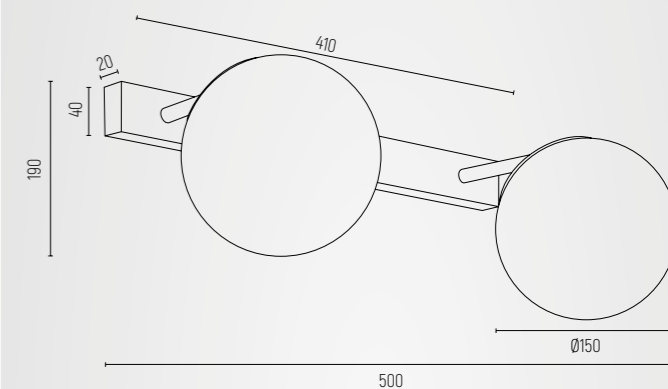











SATELITE 3989



SATELITE 841

SATELITE PLUS SATELITE

-  4744 - opal mat, mosiądz
-  3988 - opal mat, chrom
-  3989 - grafit lister, chrom
-  kinkiet 1 pt.
-  4744 - szkło, stal mosiądzowana
-  3988, 3989 - szkło, stal chromowana
-  E27 (nie zawiera źródła światła) / 230V | 1 x 15W (max)
-  220 wys. | 150 szer. | 230 gt.
-  0,7
-  IP 44
-  możliwość zamontowania włącznika na przyścienniku

SATELITE PLUS SATELITE

-  1052 - opal mat, mosiądz
-  840 - opal mat, chrom
-  841 - grafit lister, chrom
-  kinkiet 2 pt.
-  1052 - szkło, stal mosiądzowana
-  840, 841 - szkło, stal chromowana
-  E27 (nie zawiera źródła światła) / 230V | 2 x 15W (max)
-  190 wys. | 500 szer. | 230 gt.
-  1,4
-  IP 44



SATELITE 2531



SATELITE 2532



SATELITE 5021











SATELITE 5020









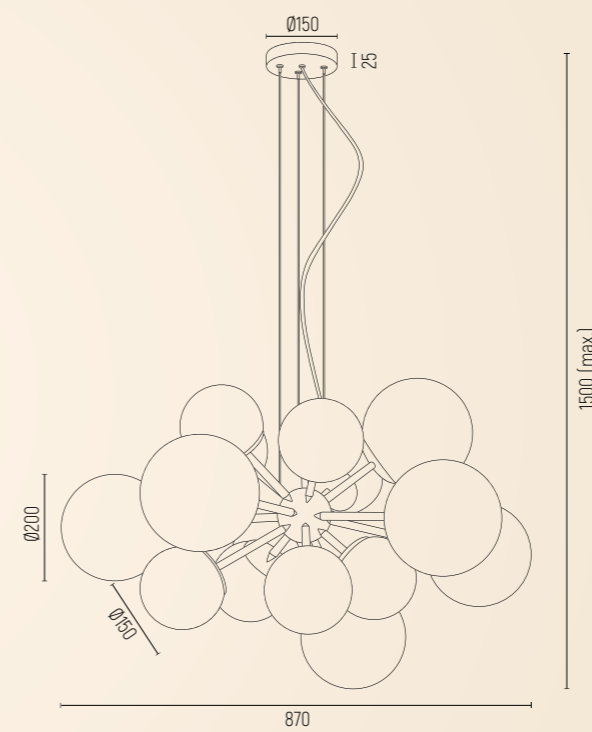
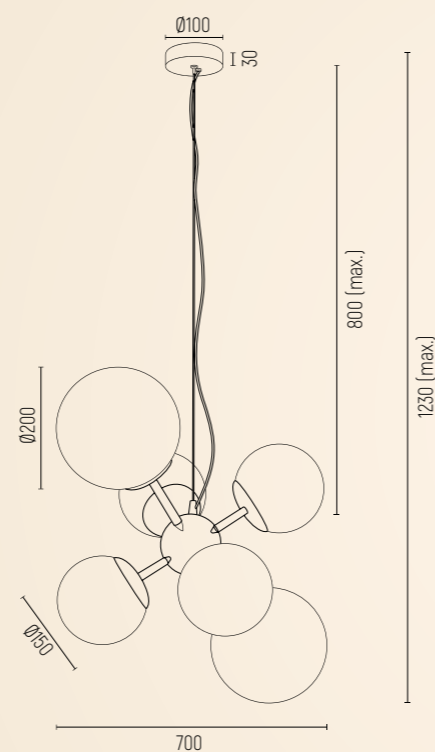



SATELITE 5022

SATELITE

-  **2531** - opal, chrom
-  **2532** - opal, mosiądz
-  żyrandol 6 pt.
-  **2531** - szkło, stal chromowana
2532 - szkło, stal mosiądzowana
-  E27 (nie zawiera źródła światła) / 230V | 6 x 15W (max)
-  1230 (linka 800) wys. | 700 szer. | 460 g.
-  4,2
-  IP 20
-  możliwość modyfikacji na włączenie 4+2, 3+3



SATELITE

-  **5021** - opal mat, chrom
-  **5022** - lister grafit, chrom
-  **5020** - mix opal mat + lister grafit, chrom
-  żyrandol 15 pt.
-  szkło, stal chromowana
-  E27 (nie zawiera źródła światła) / 230V | 15 x 15W (max)
-  1500 (linka 800) mm wys. | 870 szer. | 870 g.
-  7,5
-  IP 20
-  możliwość modyfikacji na włączenie 10+5, 7+8 itd.



SEKWANA 3050



SEKWANA 3051

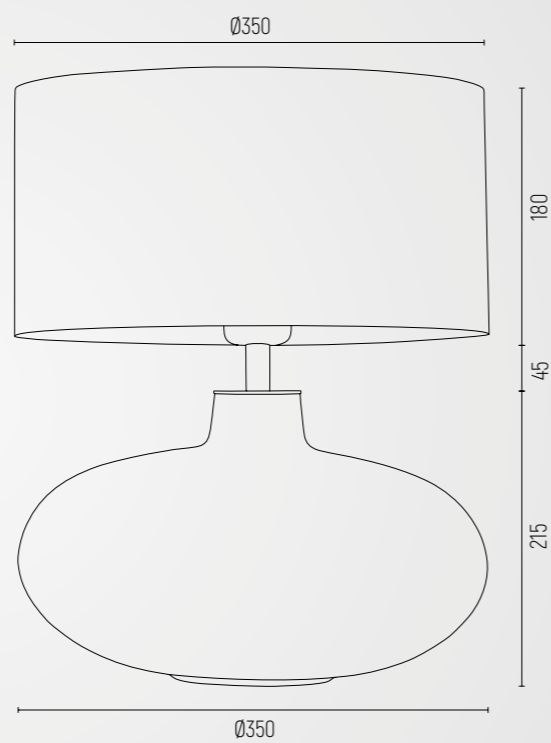

SEKWANA

- 3050 - biały, dymny
- 3051 - biały, transparentny
- lampa stołowa 1 pt.
- abażur, szkło
- E27 (nie zawiera źródła światła) / 230V | 1 x 15W (max)
- 420 wys. | 350 szer. | 350 gł.
- 2,7
- IP 20



SERAFINO 2080

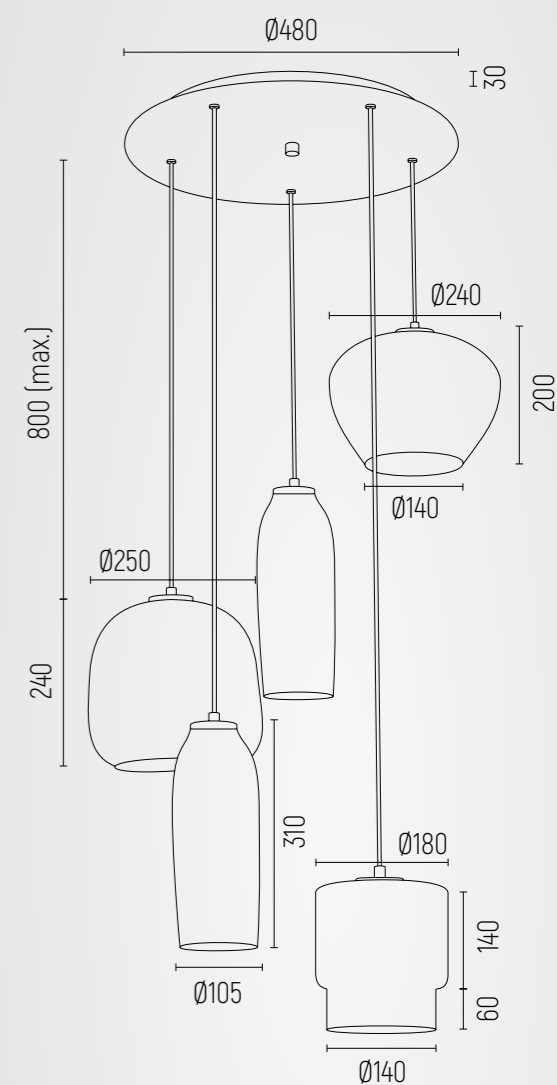





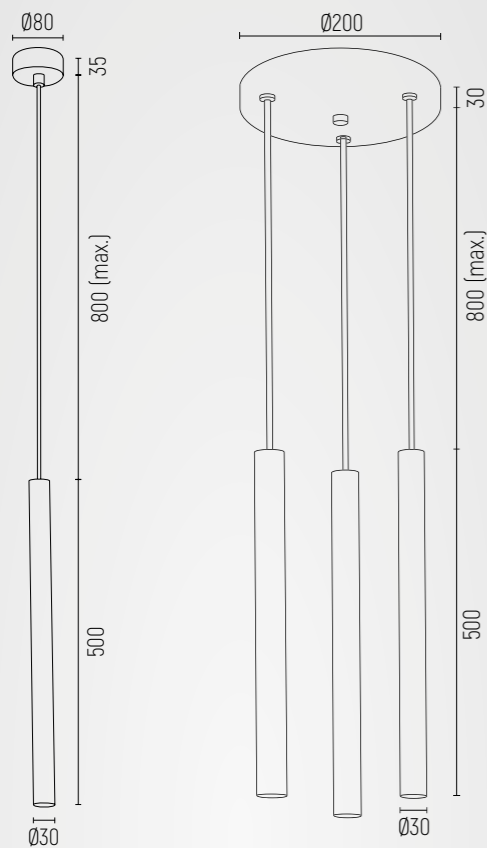



SERAFINO





- 2080 - dymny, czarny mat
- lampa wisząca 5 pt.
- szkło, stal lakierowana
- E27 (nie zawiera źródła światła) / 230V | 5 x 15W (max)
- 1500 wys. | 600 szer. | 600 gł.
- 7,2
- IP 20
- okrągła podsufitka/możliwość modyfikacji na włączanie 2+3



SICILIA PLUS

-  mosiądz, czarna struktura
-  stal mosiądzowana, stal lakierowana
-  IP 20
-  możliwość skompletowania z kolekcjami TORRE, JASPER

-  **8104** –lampa wisząca 1 pt.
-  G9 (nie zawiera źródła światła) / 230V | 1 x 6W (max)
-  przewód max 800, całość 1335 wys. | 80 szer. | 80 g.
-  0,5

-  **6191** –lampa wisząca 3 pt.
-  G9 (nie zawiera źródła światła) / 230V | 3 x 6W
-  przewód max 800, całość 1330 wys. | 200 szer. | 200 g.
-  1,6



SICILIA PLUS 8104









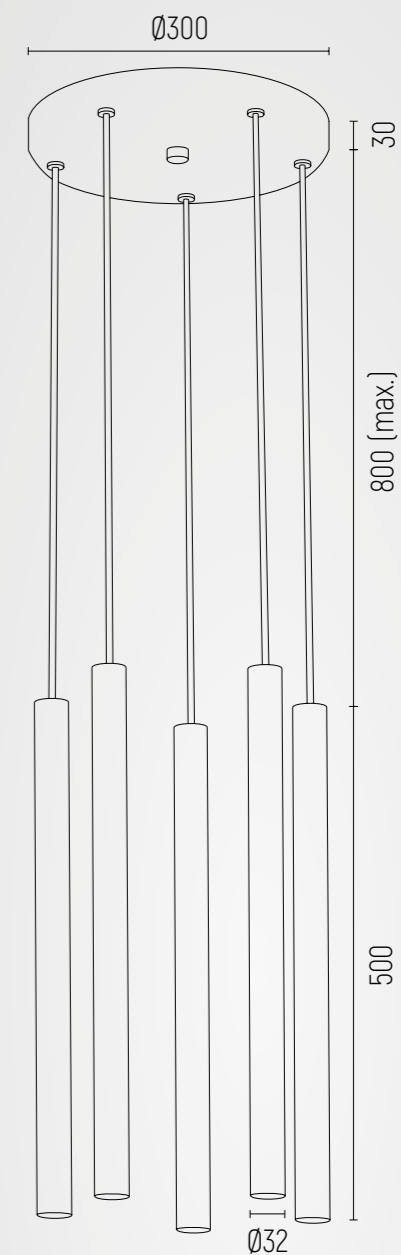

SICILIA PLUS 6191



SICILIA PLUS 2144



SICILIA PLUS

-  **2144** – mosiądz, czarna struktura
-  lampa wisząca 5 pt.
-  stal mosiądzowana, stal lakierowana
-  G9 (nie zawiera źródła światła) / 230V | 5 x 6W (max)
-  przewód max 800, całość 1330 wys. | 300 szer. | 300 g.
-  3,2
-  IP 20
-  możliwość skompletowania z kolekcjami TORRE, JASPER



SICILIA 4752

SICILIA 6106

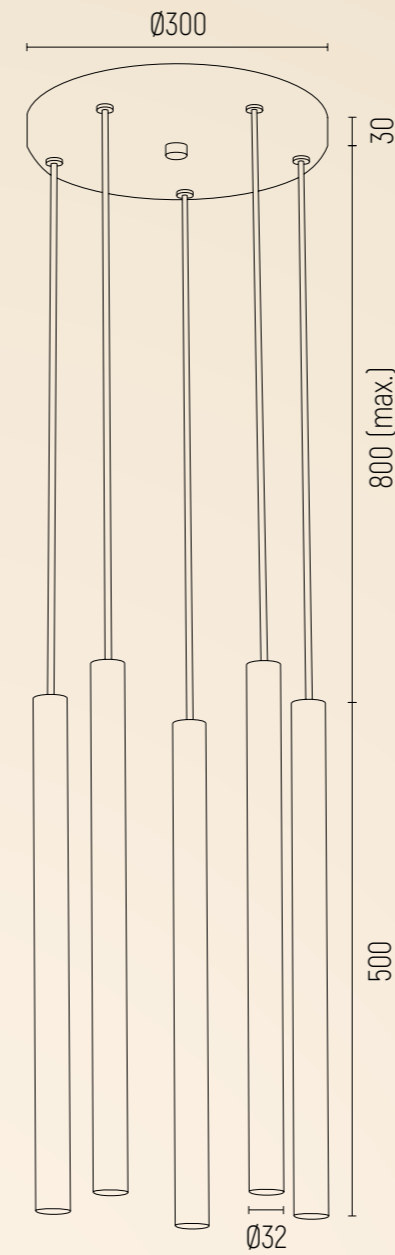

SICILIA 2109

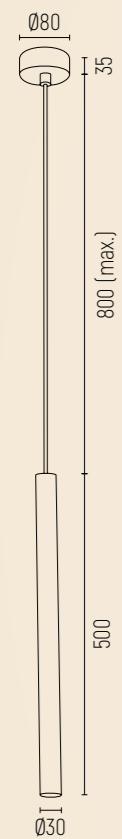

SICILIA

- mosiądz, czarna struktura
- stal mosiądzowana, stal lakierowana
- IP 20
- możliwość zastosowania modułu LED o temperaturze barwowej 4000K - nieodpłatnie
możliwość skompletowania z kolekcjami TORRE, JASPER

- 4752** - lampa wisząca 1 pt.
- LED (zintegrowany) / 230V / 3000K | 1 x 4,5W
- przewód max 800, całość 1335 wys. | 80 szer. | 80 g.
- 0,5

- 6106** - lampa wisząca 3 pt.
- LED (zintegrowany) / 230V / 3000K | 3 x 4,5W
- przewód max 800, całość 1330 wys. | 200 szer. | 200 g.
- 1,6

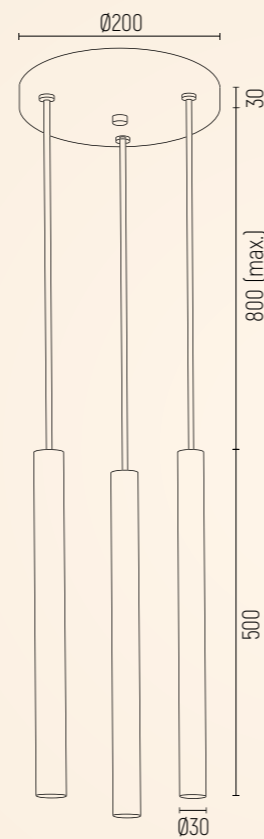



SICILIA

- 2109** - mosiądz, czarna struktura
- lampa wisząca 5 pt.
- stal mosiądzowana, stal lakierowana
- LED (zintegrowany) / 230V / 3000K | 5 x 4,5W
- przewód max 800, całość 1330 wys. | 300 szer. | 300 g.
- 3,2
- IP 20
- możliwość zastosowania modułu LED o temperaturze barwowej 4000K - nieodpłatnie



SINES

-  **4214** - szalwia struktura, el. mosiądzowane
-  **4215** - biały struktura, el. mosiądzowane
-  **4216** - granat struktura, el. mosiądzowane
-  lampa wisząca 1 pt.
-  stal lakierowana, stal mosiądzowana
-  E27 (nie zawiera źródła światła) / 230V | 1 x 15W (max)
-  przewód max. 800, całość 1030 wys. | 140 szer. | 140 g.
-  0,6
-  IP 20

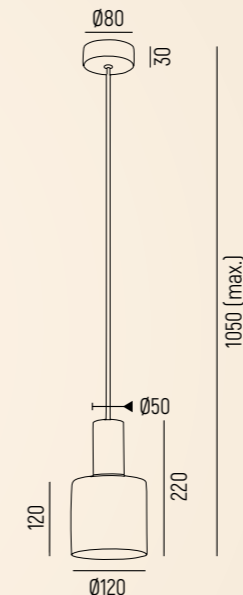

SINES

-  **4217** - szalwia struktura, el. mosiądzowane
-  **4218** - koral struktura, el. mosiądzowane
-  **4219** - czarny struktura, el. mosiądzowane
-  lampa wisząca 1 pt.
-  stal lakierowana, stal mosiądzowana
-  E27 (nie zawiera źródła światła) / 230V | 1 x 15W (max)
-  przewód max. 800, całość 1050 wys. | 120 szer. | 120 g.
-  0,6
-  IP 20



SINES

- 4220 - biały struktura, el. miedziane
- 4221 - granat struktura, el. miedziane
- 4222 - czarny struktura, el. miedziane
- lampa wisząca 1 pt.
- stal lakierowana, stal miedziana
- E27 (nie zawiera źródła światła) / 230V | 1 x 15W (max)
- przewód max. 800, całość 1030 wys. | 220 szer. | 220 g.
- 0,8
- IP 20

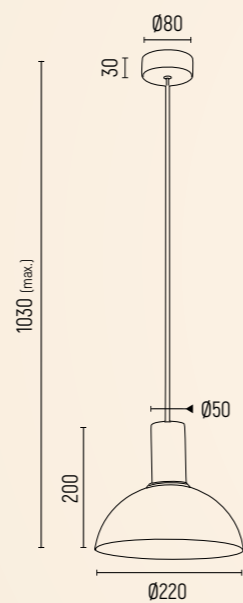

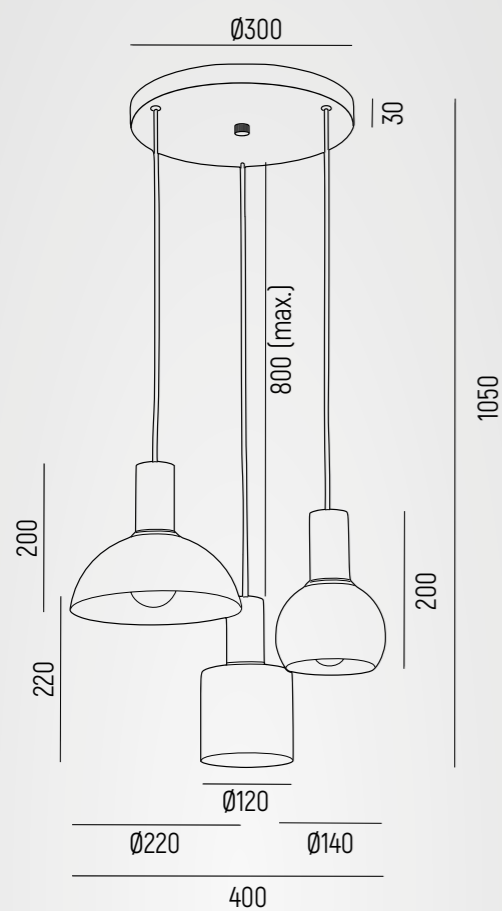

SINES

-  1468 - biały struktura, el. mosiądzowane
-  1469 - koral struktura, el. mosiądzowane
-  1470 - szalwia struktura, el. mosiądzowane
-  1471 - granat struktura, el. mosiądzowane
-  1472 - czarny struktura, el. mosiądzowane
-  1479 - mix (szalwia, koral, czarny) struktura, el. mosiądzowane
-  1480 - mix (biały, czarny, koral) struktura, el. mosiądzowane
-  lampa wisząca 3 pt. na okrągłej podsufitce
-  stal lakierowana, stal mosiądzowana
-  E27 (nie zawiera źródła światła) / 230V | 3 x 15W (max)
-  przewód max. 800, całość 1050 wys. | 400 szer. | 400 gł.
-  2
-  IP 20
-  możliwość modyfikacji na włączenie 1+2

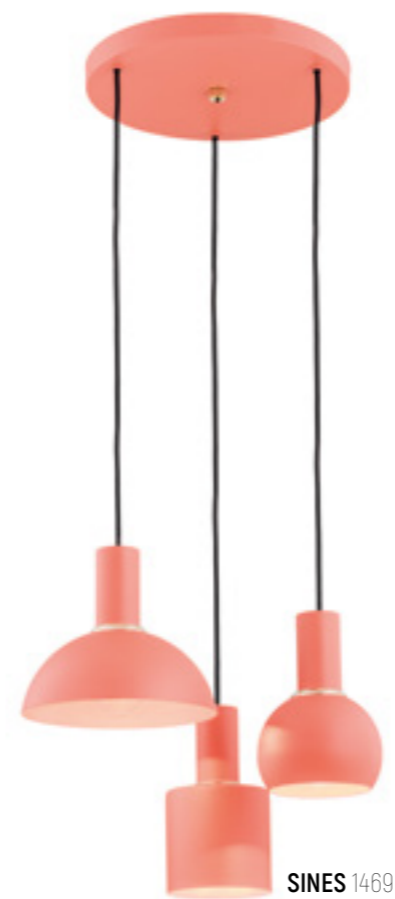

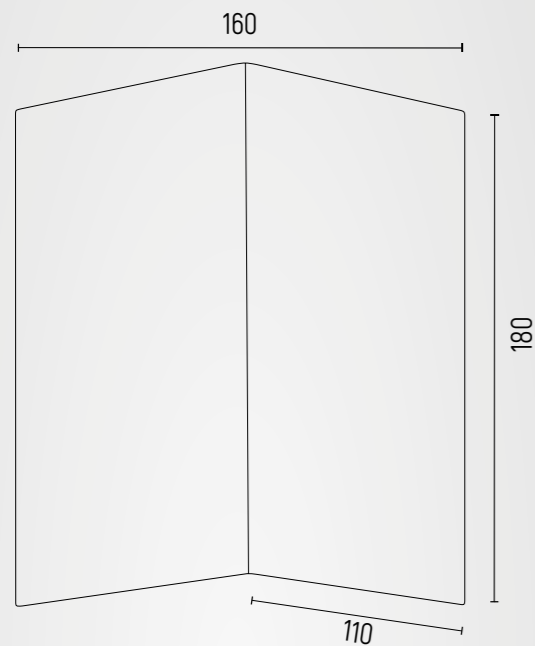

SKIATOS

- 914 - czarny struktura
- 915 - biały struktura
- 916 - złoty struktura
- 917 - chrom
- 918 - msiądz
-  kinkiet 2 pt.
-  914, 915, 916 - stal lakierowana
-  917 - stal chromowana
-  918 - stal msiądzowana
-  GU10 (nie zawiera źródła światła) / 230V | 2 x 5W (max)
-  180 wys. | 160 szer. | 80 gł.
-  0,6
-  IP 20
-  świeci góra-dół

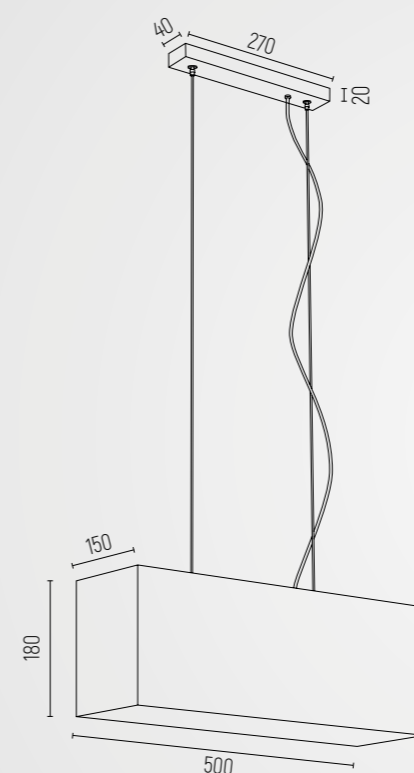

TENERYFA

-  1424 - biały struktura, złoty
-  1425 - czarny struktura, złoty
-  lampa wisząca 3 pt.
-  stal lakierowana, formatka pcv
-  E27 (nie zawiera źródła światła) / 230V | 3 x 15W (max)
-  1000 (linka 800) wys. | 500 szer. | 150 gł.
-  3,5
-  IP 20



TOMAR 1477















TOMAR 1478



TOMAR 1481

TOMAR

-  1477 - opal mat, chrom
-  1478 - opal mat, czarna struktura, el. mosiądzowane
-  1481 - opal mat, mosiądz
-  żyrandol 3 pt.
-  1477 - szkło, stal chromowana
-  1478 - szkło, stal lakierowana, stal mosiądzowana
-  1481 - szkło, stal mosiądzowana
-  E27 (nie zawiera źródła światła) / 230V | 3 x 15W (max)
-  290 wys. | 510 szer. | 510 gt.
-  2
-  IP 20
-  możliwość modyfikacji na włączenie 1+2

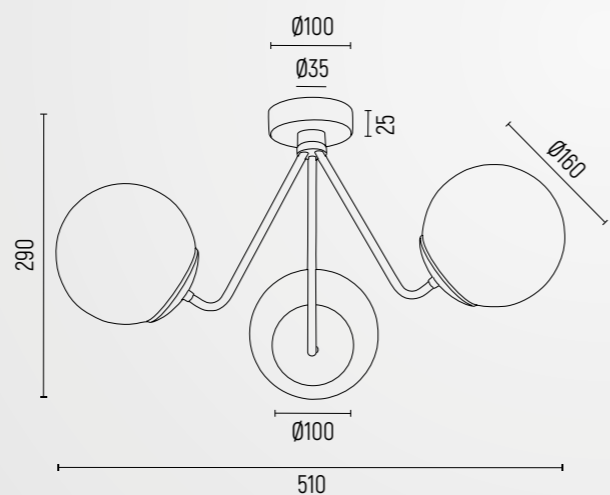

TORRE 7082



TORRE 7083



TORRE

-  7082 - czarna struktura
-  7083 - czarna struktura, mosiądz
-  lampa podłogowa 2 pt.
-  7082 - stal lakierowana
-  7083 - stal lakierowana, stal mosiądzowana
-  G9 (nie zawiera źródła światła) / 230V | 2 x 6W LED (max)
-  1500 wys. | 300 szer. | 300 gt.
-  2,3
-  IP 20
-  możliwość regulacji, możliwość skompletowania z kolekcjami ETNA, ETNA PLUS, SICILIA, SICILIA PLUS, JASPER



TROY

E27 (nie zawiera źródła światła) / 230V | 1 x 15W (max)

IP 20

4284 - beżowy z czarnym przeszyciem, czarna struktura

lampa stołowa 1 pt.

abażur, stal lakierowana

430 wys. | 350 szer. | 350 g.

1,75

4282 - beżowy z czarnym przeszyciem, czarna struktura

lampa wisząca 1 pt.

abażur, stal lakierowana

przewód max. 800, całość 1030 wys. | 450 szer. | 450 g.

0,7

4283 - beżowy z czarnym przeszyciem, czarna struktura, el. mosiądzowane

lampa podłogowa 1 pt.

abażur, stal lakierowana, stal mosiądzowana

1540 wys. | 450 szer. | 450 g.

5,9

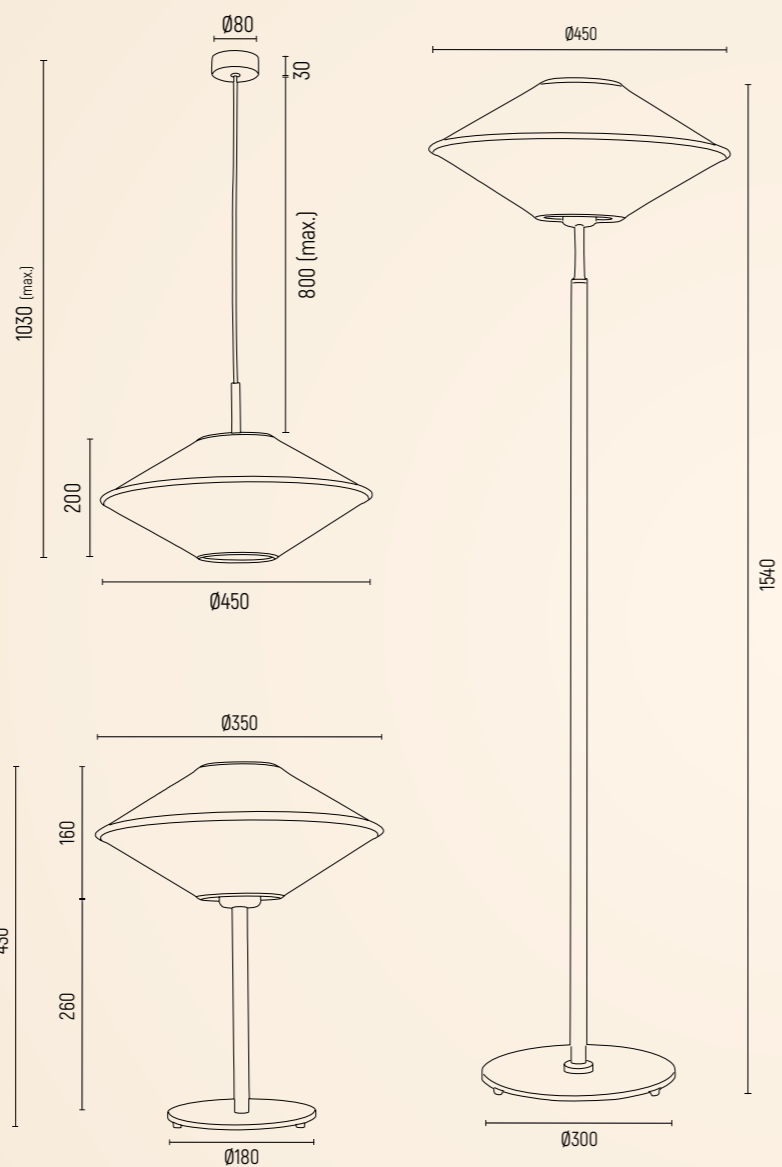

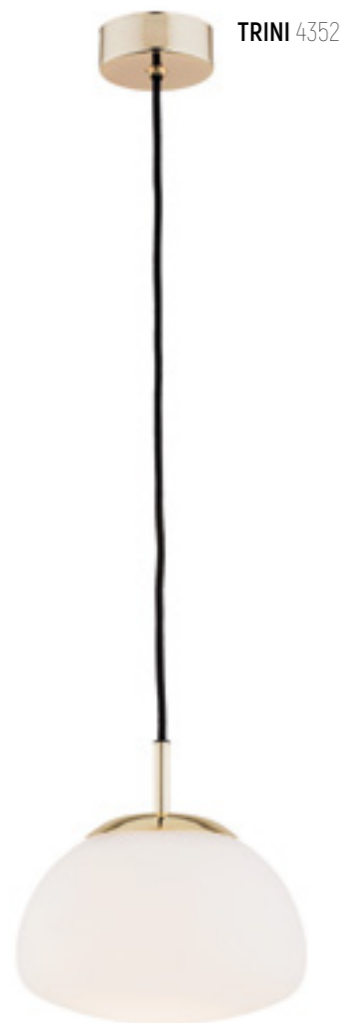

TRINI 4352



TRINI 4331



TRINI 4333

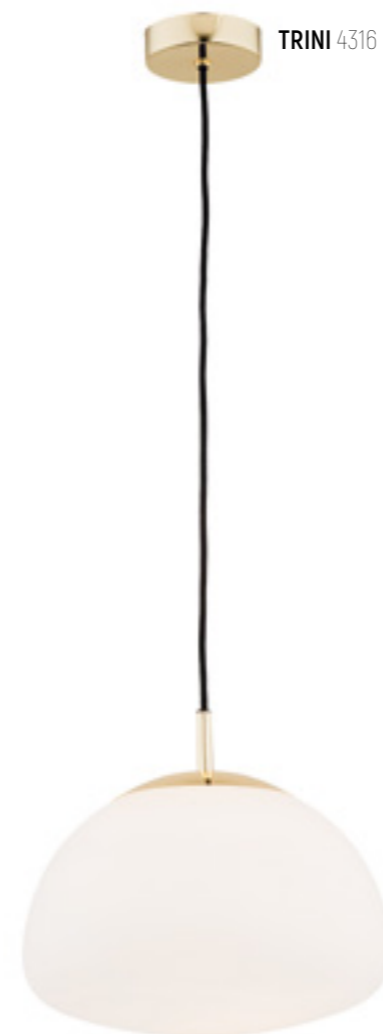

TRINI 4316



TRINI 4332

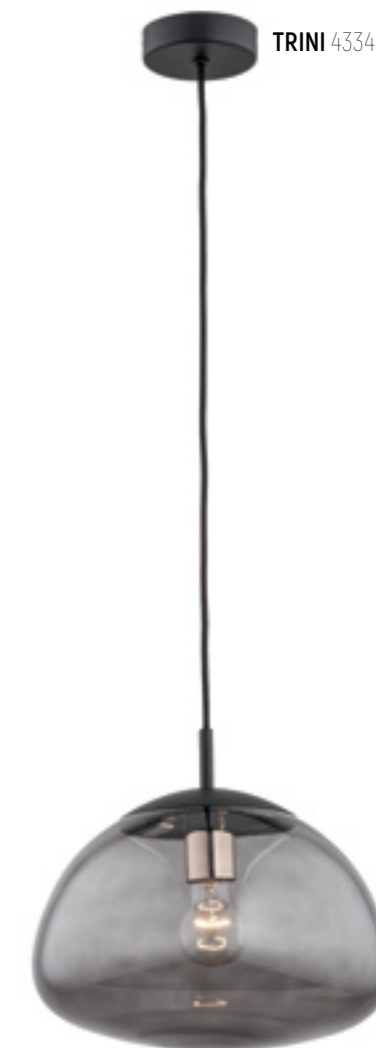

TRINI 4334

TRINI

-  4352 - opal mat, mosiądz
-  4331 - transparentny, czarny mat, el. mosiądzowane
-  4333 - dymny, czarny mat, el. mosiądzowane
-  lampa wisząca 1 pt. S
-  4352 - szkło, stal mosiądzowana
-  4331, 4333 - szkło, stal lakierowana, stal mosiądzowana
-  E27 (nie zawiera źródła światła) / 230V | 1 x 15W (max)
-  przewód max. 800, całość 1030 wys. | 200 szer. | 200 g.
-  1,2
-  IP 20

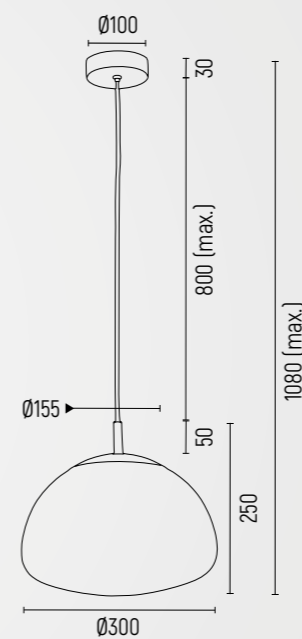
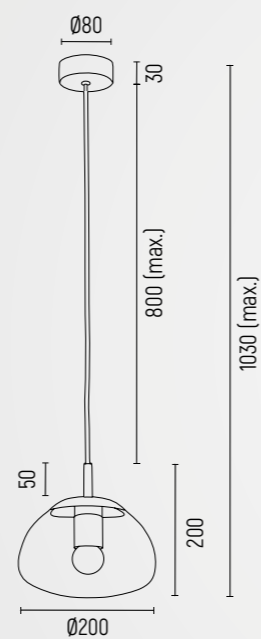

TRINI

-  4316 - opal mat, mosiądz
-  4332 - transparentny, czarny mat, el. mosiądzowane
-  4334 - dymny, czarny mat, el. mosiądzowane
-  lampa wisząca 1 pt. M
-  4316 - szkło, stal mosiądzowana
-  4332, 4334 - szkło, stal lakierowana, stal mosiądzowana
-  E27 (nie zawiera źródła światła) / 230V | 1 x 15W (max)
-  przewód max. 800, całość 1080 wys. | 300 szer. | 300 g.
-  2
-  IP 20



TRINI 4317



TRINI 4351



TRINI 4350



TRINI 1492









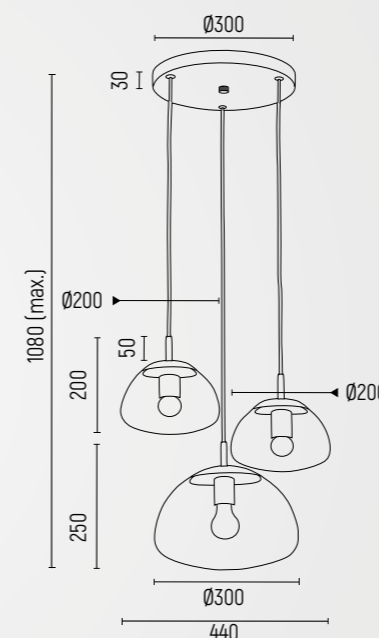
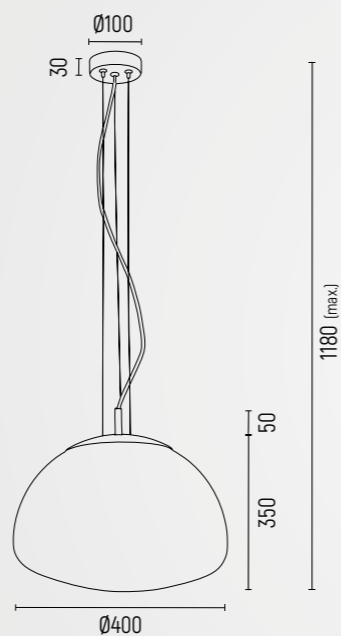

TRINI 1493

TRINI





-  4317 - opal mat, mosiądz
-  4351 - transparentny, czarny mat, el. mosiądzowane
-  4350 - dymny, czarny mat, el. mosiądzowane
-  lampa wisząca 1 pt. L
-  4317 - szkło, stal mosiądzowana
-  4351, 4350 - szkło, stal lakierowana, stal mosiądzowana
-  E27 (nie zawiera źródła światła) / 230V | 1 x 15W (max)
-  linki max. 800, całość 1180 wys. | 400 szer. | 400 gł.
-  3
-  IP 20







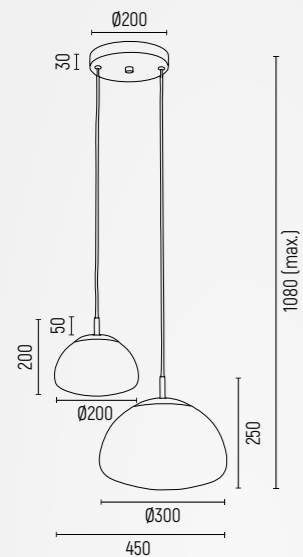

TRINI

-  1492 - transparentny, czarny mat, el. mosiądzowane
-  1493 - dymny, czarny mat, el. mosiądzowane
-  lampa wisząca 3 pt. na okrągłej podsufitce
-  szkło, stal lakierowana, stal mosiądzowana
-  E27 (nie zawiera źródła światła) / 230V | 3 x 15W (max)
-  przewód max. 800, całość 1080 wys. | 440 szer. | 440 gł.
-  4,2
-  IP 20





TRINI

-  opal mat, mosiądz
-  szkło, stal mosiądzowana
-  IP 20
-  możliwość zastosowania stali chromowanej lub lakierowanej zamiast stali mosiądzowanej

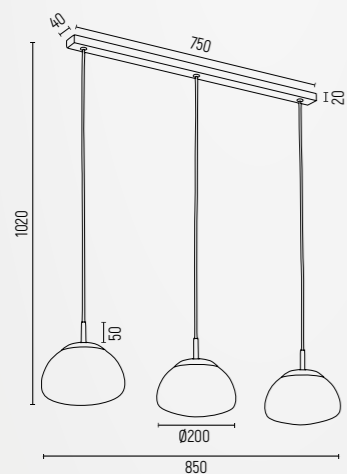

-  **902** -lampa wisząca 2 pt. na okrągłej podsufitce
-  E27 (nie zawiera źródła światła) / 230V | 2 x 15W (max)
-  przewód max. 800, całość 1080 wys. | 450 szer. | 300 gł.
-  3,1
-  klosz mały i średni/możliwość modyfikacji na włączanie 1+1



-  **1494** -lampa wisząca 3 pt. listwa
-  E27 (nie zawiera źródła światła) / 230V | 3 x 15W (max)
-  przewód max. 800, całość 1020 wys. | 850 szer. | 200 gł.
-  3,2
-  klosze małe/możliwość modyfikacji na włączanie 1+2



TRINI 902











TRINI 1494



PALLADO 4993

PALLADO

-  **4993** - opal mat, mosiądz
-  lampa wisząca 1 pt.
-  szkło, stal mosiądzowana
-  E27 (nie zawiera źródła światła) / 230V | 1 x 15W (max)
-  1150 wys. | 140 szer. | 140 gł.
-  0,8
-  IP 20
-  możliwość zastosowania stali chromowanej lub lakierowanej zamiast stali mosiądzowanej

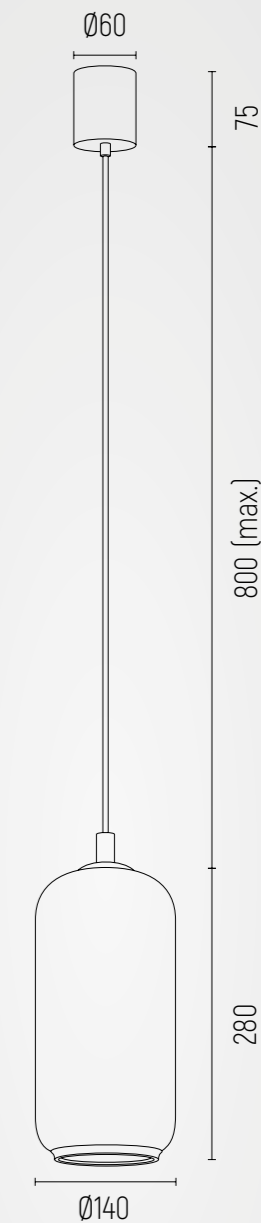







VALIANO 4994

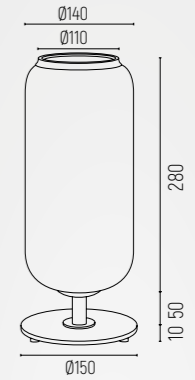



VALIANO 4995







-  4994 - lampa stołowa 1 pt.
-  340 wys. | 150 szer. | 150 g.
-  1,65



-  4995 - lampa podłogowa 1 pt.
-  1610 wys. | 300 szer. | 300 g.
-  5,3

VALIANO

-  opal mat, czarna struktura
-  szkło, stal lakierowana
-  E27 (nie zawiera źródła światła) / 230V | 1 x 15W (max)
-  IP 20
-  możliwość zastosowania stali chromowanej lub lakierowanej zamiast stali mosiądzowanej

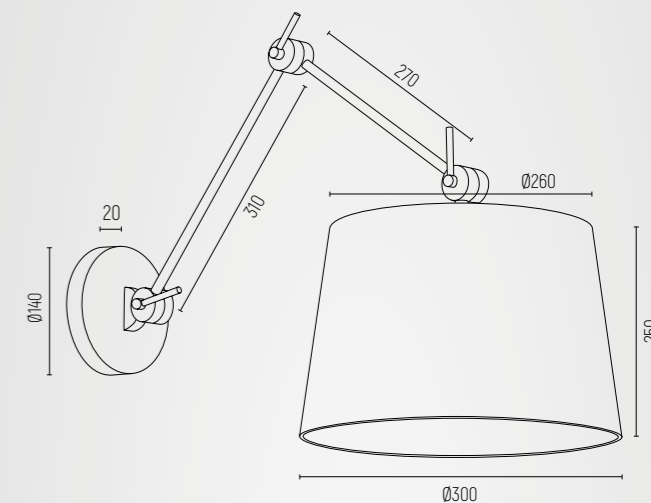

ZAKYNTOS PLUS ZAKYNTOS



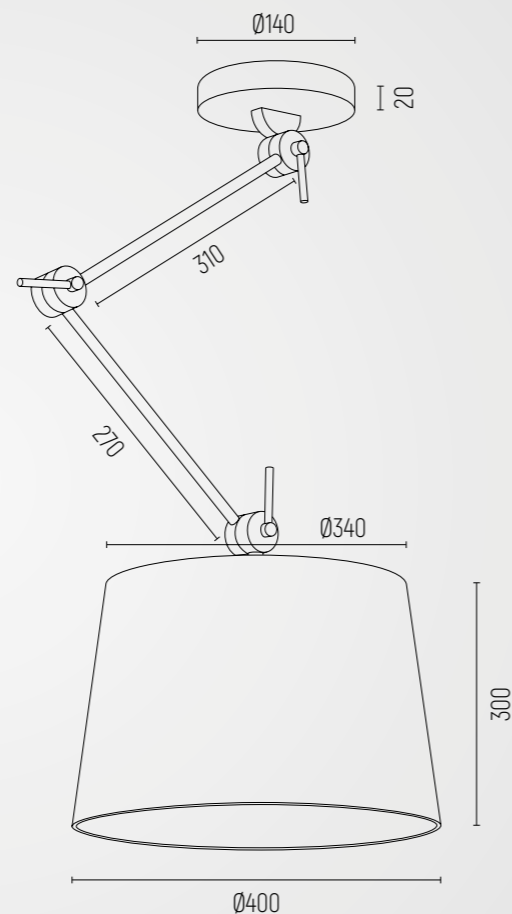

- 4895 - biały, mosiądz
- 4896 - czarny, mosiądz
- 3548 - biały, chrom
- 3549 - beżowy, chrom
- 3550 - czarny, chrom
- lampa wisząca 1 pł.
- 4895, 4896 - abażur, stal mosiądzowana
3548, 3549, 3550 - abażur, stal chromowana
- E27 (nie zawiera źródła światła) / 230V | 1 x 15W (max)
- 950 (max) wys. | 400 szer. | 400 gł.
- 1,4
- IP 20
- 4895, 4896, 3548, 3549, 3550 - możliwość regulacji
3548, 3550 - abażur siatkowaty stożek
3549 - abażur gładki stożek
możliwość zastosowania stali lakierowanej zamiast stali mosiądzowanej / chromowanej







ZAKYNTOS PLUS ZAKYNTOS

- 4897 - biały, mosiądz
- 4898 - czarny, mosiądz
- 3545 - biały, chrom
- 3546 - beżowy, chrom
- 3547 - czarny, chrom
- kinkiet 1 pł.
- 4897, 4898 - abażur, stal mosiądzowana
3545, 3546, 3547 - abażur, stal chromowana
- E27 (nie zawiera źródła światła) / 230V | 1 x 15W (max)
- 500 (max) wys. | 300 szer. | 750 gł.
- 1,4
- IP 20
- 4897, 4898 - możliwość regulacji
3545, 3546, 3547 - abażur siatkowaty stożek/
możliwość regulacji, możliwość zamontowania
włącznika na przycienniku
możliwość zastosowania stali lakierowanej zamiast stali mosiądzowanej / chromowanej

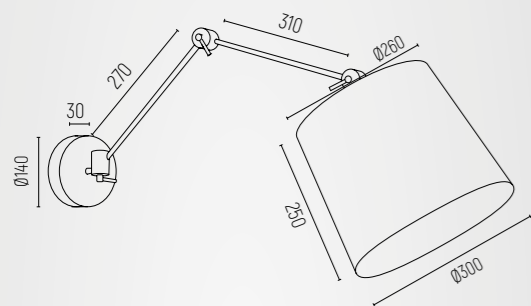



ZAKYNTOS BIS

-  **3933, 3953** - biały, chrom
-  **3935, 3952** - czarny, chrom
-  abażur, stal chromowana
-  E27 (nie zawiera źródła światła) / 230V | 1 x 15W (max)
-  możliwość zastosowania stali lakierowanej zamiast stali chromowanej

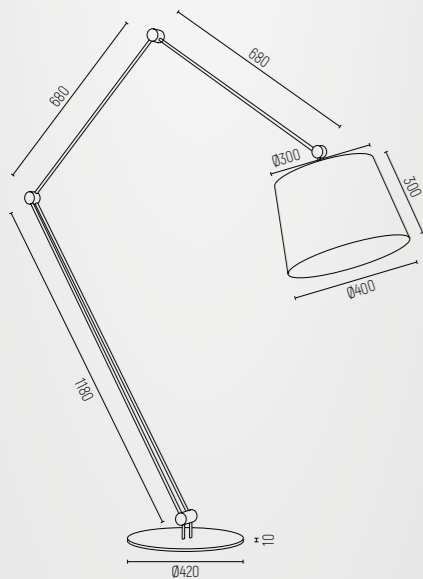

-  **3933, 3935** - kinkiet 1 pt.
-  500 (max) wys. | 300 szer. | 750 g.
-  1,4
-  możliwość regulacji w dwóch płaszczyznach góra-dół i prawo-lewo/ możliwość zamontowania włącznika na przyścienniku



-  **3953, 3952** - lampa podłogowa 1 pt.
-  2000 (max) wys. | 450 szer. | 1500 (max) g.
-  9,8
-  możliwość regulacji



ZAKYNTOS BIS 3933



ZAKYNTOS BIS 3935



ZAKYNTOS BIS 3953



ZAKYNTOS BIS 3952



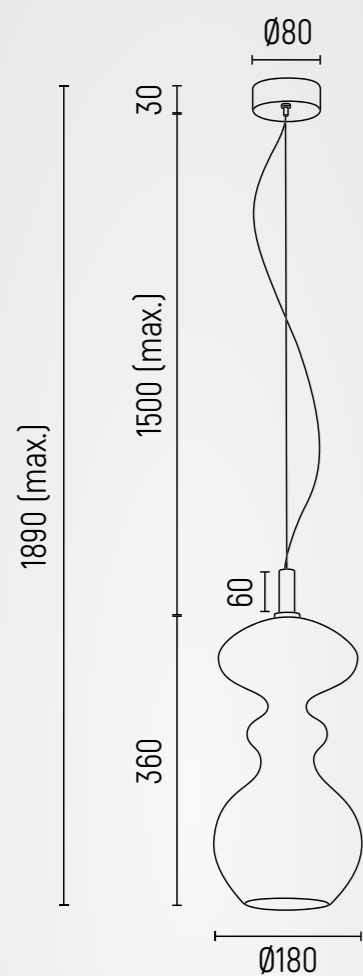

BILBAO 4203









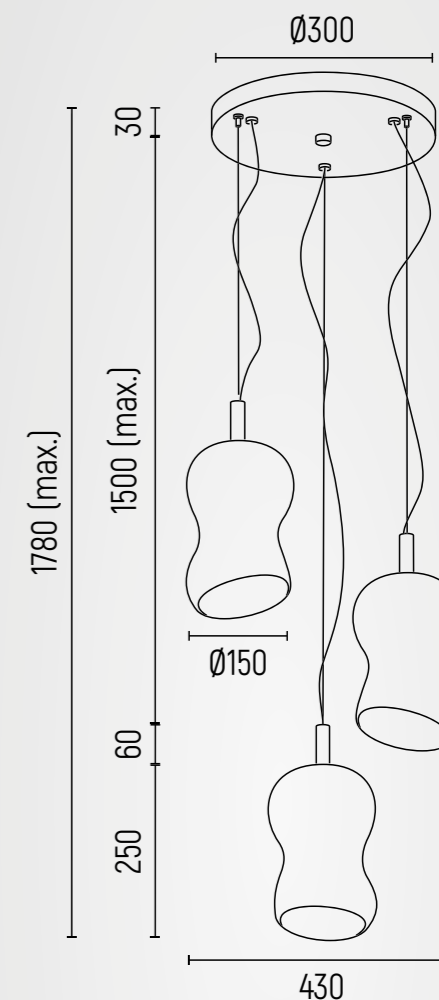

BILBAO 4204











CADIZ 1464



BILBAO

-  4203, 4204 - transparentny, mosiądz
-  lampa wisząca 1 pt.
-  szkło kryształowe, stal mosiądzowana
-  E27 (nie zawiera źródła światła) / 230V | 1 x 15W (max)
-  linka max. 1500, całość 1890 wys. | 180 szer. | 180 g.
-  3,3
-  IP 20
-  możliwość zastosowania elementów chromowanych zamiast mosiądzowanych

CADIZ

-  1464 - transparentny, mosiądz
-  lampa wisząca 3 pt. na okrągłej podsufitce
-  szkło kryształowe, stal mosiądzowana
-  E27 (nie zawiera źródła światła) / 230V | 3 x 15W (max)
-  linka max. 1500, całość 1780 wys. | 430 szer. | 430 g.
-  5,6
-  IP 20
-  możliwość zastosowania elementów chromowanych zamiast mosiądzowanych/możliwość zastosowania modyfikacji włączenia 1+2, możliwość skompletowania z kolekcją SALERNO, VENETO 8036

CRUZ

- transparentny, msiądz
- szkło kryształowe, stal msiądzowana
- E14 (nie zawiera źródła światła) / 230V | 1 x 7W (max)
- IP 20

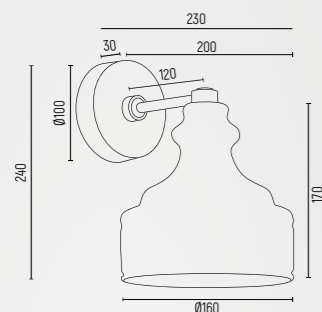

- 4199 - kinkiet 1 pt.
- 240 wys. | 160 szer. | 230 gł.
- 1,7
- możliwość zastosowania elementów chromowanych zamiast msiądzowanych/
możliwość zamontowania włącznika na przyścienniku

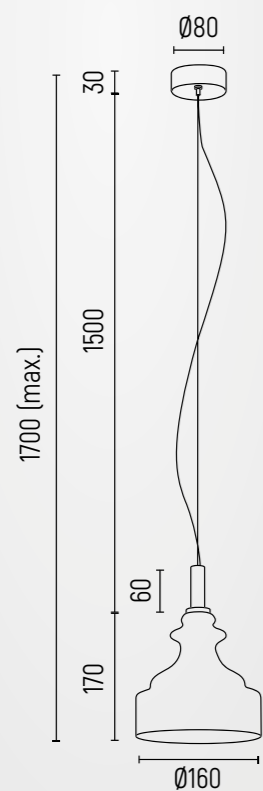

- 4198 - lampa wisząca 1 pt.
- linka max. 1500, całość 1700 wys. | 160 szer. | 160 gł.
- 1,8
- możliwość zastosowania elementów chromowanych zamiast msiądzowanych



CRUZ 4199



CRUZ 4198





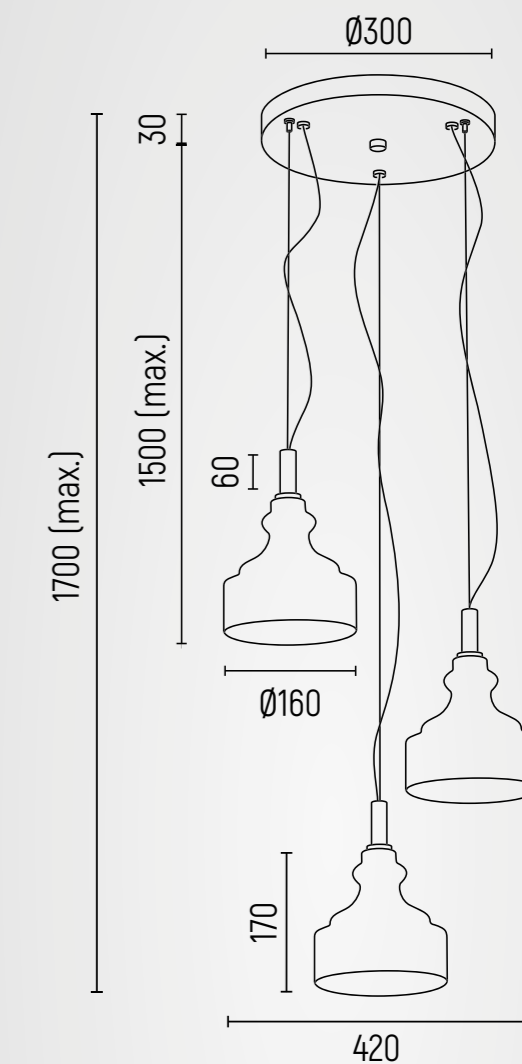

CRUZ 1462







CRUZ

- 1462 - transparentny, msiądz
- lampa wisząca 3 pt. na okrągłej podsufitce
- szkło kryształowe, stal msiądzowana
- E14 (nie zawiera źródła światła) / 230V | 3 x 7W (max)
- linka max. 1500, całość 1700 wys. | 420 szer. | 420 gł.
- 4,6
- IP 20
- możliwość zastosowania elementów chromowanych zamiast msiądzowanych/
możliwość zastosowania modyfikacji włączania 1+2

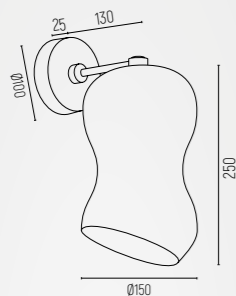

DEPORTIVO

-  transparenty, mosiądz
-  szkło kryształowe, stal mosiądzowana
-  E27 (nie zawiera źródła światła) / 230V | 1 x 15W (max)
-  IP 20
-  możliwość skompletowania z kolekcją VENETO 8037, możliwość zastosowania elementów chromowanych zamiast mosiądzu

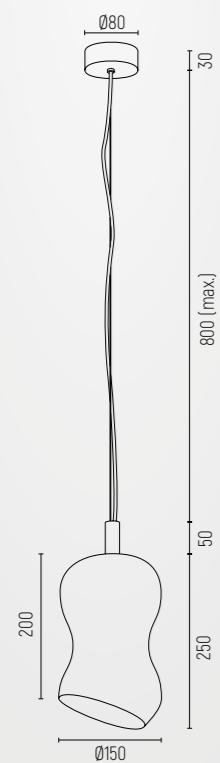

-  4741 - kinkiet 1 pt.
-  320 wys. | 150 szer. | 230 g.
-  1,5
-  możliwość zamontowania włącznika na przyścienniku



-  4742 - lampa wisząca 1 pt.
-  przewód max. 800, całość 1130 wys. | 150 szer. | 150 g.
-  1,5



DEPORTIVO 4741



SALERNO 8046







DEPORTIVO 4742







SALERNO 8038

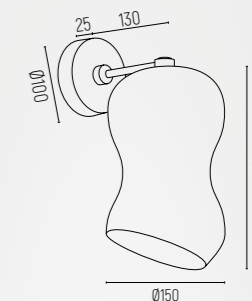

SALERNO

-  transparentny, mosiądz
-  szkło kryształowe, stal mosiądzowana
-  E27 (nie zawiera źródła światła) / 230V | 1 x 15W (max)
-  IP 20
-  możliwość skompletowania z kolekcją CADIZ, VENETO 8036, możliwość zastosowania elementów chromowanych zamiast mosiądzowanych



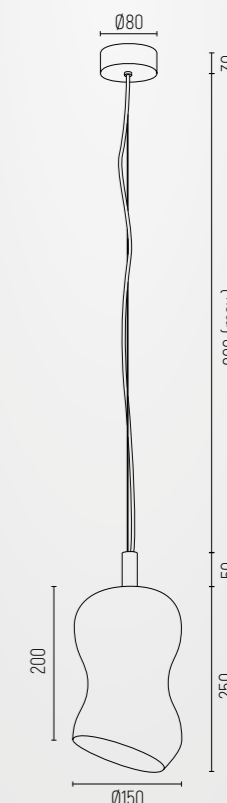



-  8046 - kinkiet 1 pt.
-  320 wys. | 150 szer. | 230 g.
-  1,5
-  możliwość zamontowania włącznika na przyścienniku





-  8038 - lampa wisząca 1 pt.
-  1130 wys. | 150 szer. | 150 g.
-  1,5

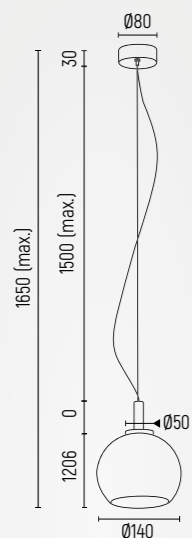

OVIEDO

-  transparentny, mosiądz
-  szkło kryształowe, stal mosiądzowana
-  E27 (nie zawiera źródła światła) / 230V | 1 x 15W (max)
-  IP 20
-  możliwość zastosowania elementów chromowanych zamiast mosiądzowanych

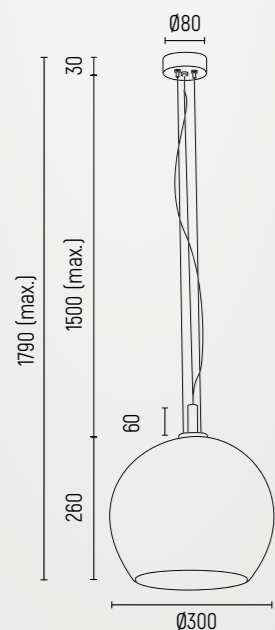

-  4200 - lampa wisząca 1 pt. mniejsza
-  linka max. 1500, całość 1650 wys. | 140 szer. | 140 gt.
-  1,5



-  4201 - lampa wisząca 1 pt. większa
-  linka max. 1500, całość 1790 wys. | 300 szer. | 300 gt.
-  3,7



OVIEDO 4200

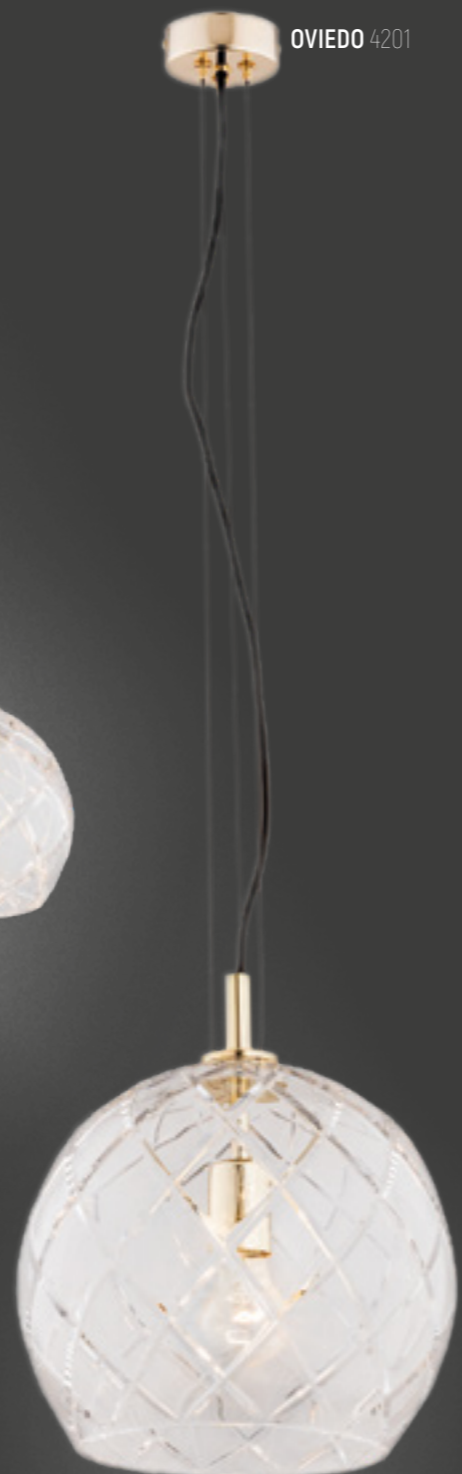

OVIEDO 4201





OVIEDO 4202







OVIEDO 1463

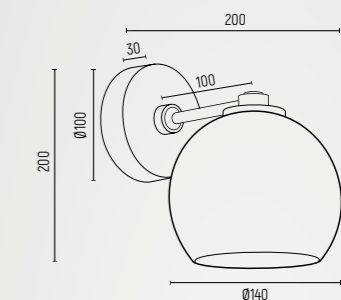



OVIEDO

-  transparentny, mosiądz
-  szkło kryształowe, stal mosiądzowana
-  IP 20

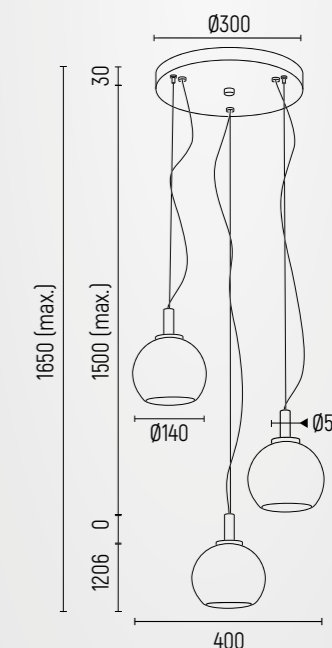

-  4202 - kinkiet 1 pt.
-  E27 (nie zawiera źródła światła) / 230V | 1 x 15W (max)
-  200 wys. | 140 szer. | 200 gt.
-  1,5
-  możliwość zastosowania elementów chromowanych zamiast mosiądzowanych/ możliwość zamontowania włącznika na przyścienniku



-  1463 - lampa wisząca 3 pt. na okrągłej podsufitce
-  E27 (nie zawiera źródła światła) / 230V | 3 x 15W (max)
-  linka max. 1500, całość 1650 wys. | 400 szer. | 400 gt.
-  3,2
-  możliwość zastosowania elementów chromowanych zamiast mosiądzowanych/ możliwość zastosowania modyfikacji włączania 1+2

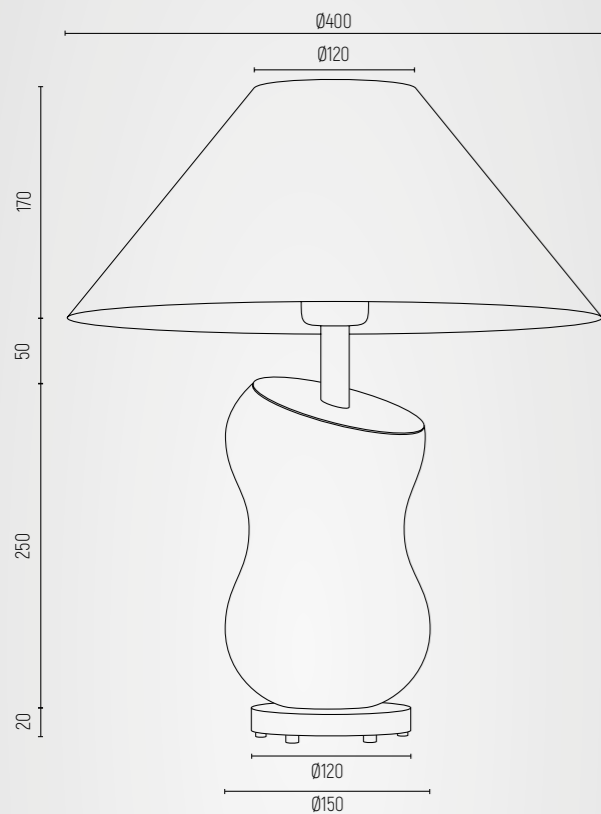

VENETO

-  **8036** - biały, transparentny, czarny, mosiądz
-  **8037** - czarny, transparentny, czarny, mosiądz
-  lampa stołowa 1 pł.
-  abażur, szkło kryształowe, stal lakierowana, stal mosiądzowana
-  E27 (nie zawiera źródła światła) / 230V | 1 x 15W (max)
-  490 wys. | 400 szer. | 400 gł.
-  2,6
-  IP 20
-  możliwość skompletowania z kolekcją: CADIZ, DEPORTIVO, SALERNO, możliwość zastosowania elementów chromowanych zamiast mosiądzowanych





VENETO 8037



VENETO 8036

AMORE

 7034, 7035 - biały struktura ze złotym paskiem

 7040, 7041 - czarny struktura ze złotym paskiem

 szkło, stal lakierowana

 IP 20

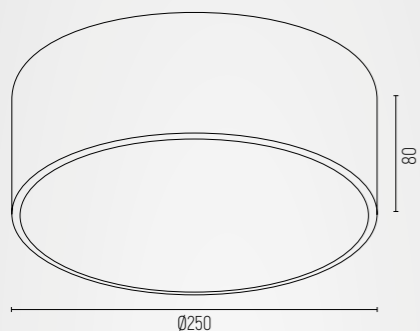



 7034, 7040 - plafon 2 pt. mały

 E27 (nie zawiera źródła światła) / 230V | 2 x 15W (max)

 80 wys. | 250 szer. | 250 g.

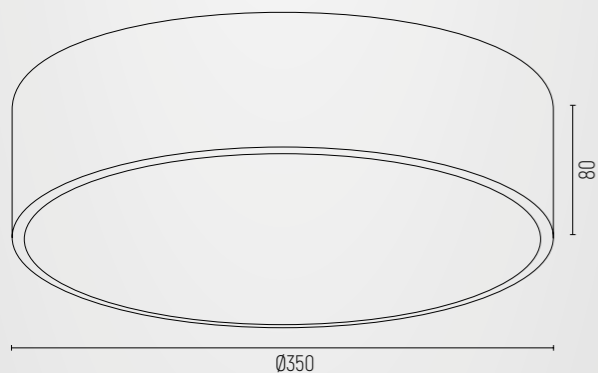
 1,5



 7035, 7041 - plafon 2 pt. średni

 E27 (nie zawiera źródła światła) / 230V | 2 x 15W (max)

 80 wys. | 350 szer. | 350 g.

 2,6

AMORE 7034



AMORE 7040



AMORE 7035



AMORE 7041



AMORE 6138





AMORE 6141





AMORE

 6138 - biały struktura ze złotym paskiem

 6141 - czarny struktura ze złotym paskiem

 plafon 3 pt. duży

 szkło, stal lakierowana

 E27 (nie zawiera źródła światła) / 230V | 3 x 15W (max)

 80 wys. | 450 szer. | 450 g.

 3,2

 IP 20

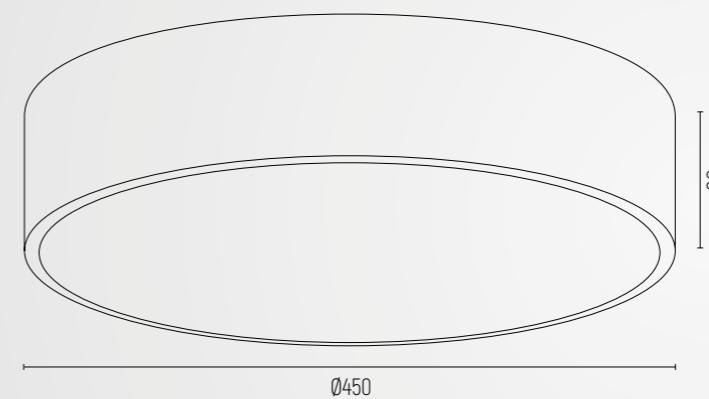



ARIZONA 3823



ARIZONA 3827



ARIZONA 3824



ARIZONA 3828



ARIZONA

- 3823, 3824 - czarna struktura
- 3827, 3828 - biały struktura
- stal lakierowana, szkło
- IP IP 20
- + możliwość zastosowania modułu LED o temperaturze barwowej 4000K - nieodpłatnie

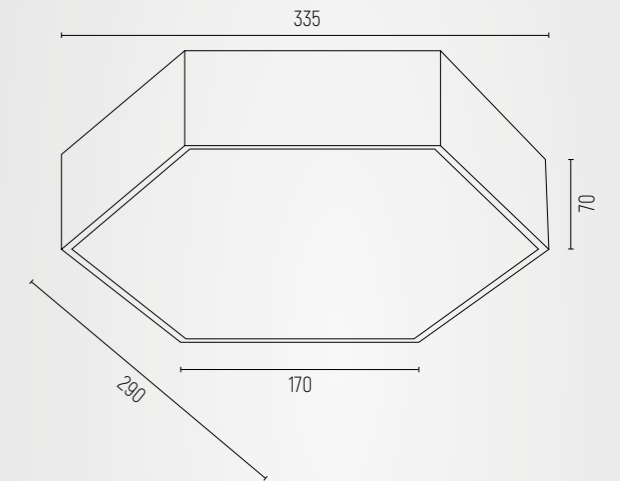

- 3823, 3827 - plafon 1 pt. duży
- + LED (zintegrowany) 230V / 2450 lm / 3000 K | 22,5W
- mm 70 wys. | 335 szer. | 290 gł.
- kg 1,8

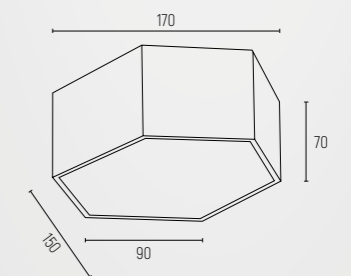

- 3824, 3828 - plafon 1 pt. mały
- + LED (zintegrowany) 230V / 2450 lm / 3000 K | 9W
- mm 70 wys. | 170 szer. | 150 gł.
- kg 0,6



ATLANTIS 4051



ATLANTIS 4050











ATLANTIS 4078







ATLANTIS 4077

ATLANTIS





-  **4050, 4051** – złoty połysk, białe wykończenie
-  stal lakierowana, formatka, plexi
-  IP 20
-  zmiana materiału wykonania/możliwość zastosowania modułu LED o temperaturze barwowej 4000K - nieodpłatnie

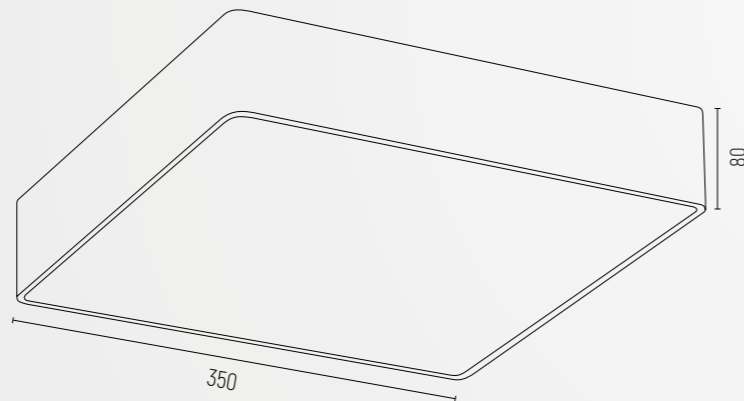
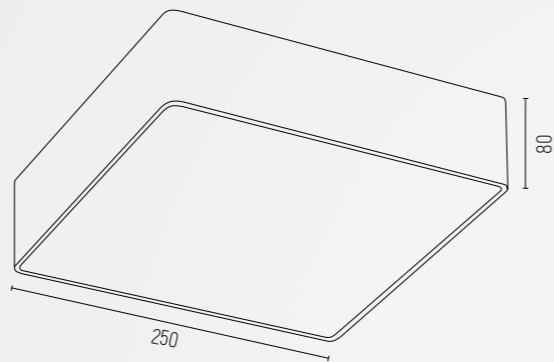



-  **4050** – plafon LED maty
-  LED (zintegrowany) / 230V / 1950 lm / 3000K | 1 x 18,5W
-  80 wys. | 250 szer. | 250 g.
-  1,5





-  **4051** – plafon LED średni
-  LED (zintegrowany) / 230V / 3900 lm / 3000K | 1 x 32W
-  80 wys. | 350 szer. | 350 g.
-  2,6



ATLANTIS

-  **4077, 4078** – złoty połysk, białe wykończenie
-  stal lakierowana, formatka, plexi
-  IP 20
-  zmiana materiału wykonania/możliwość zastosowania modułu LED o temperaturze barwowej 4000K - nieodpłatnie

-  **4077** – plafon LED maty
-  LED (zintegrowany) / 230V / 2450 lm / 3000K | 1 x 22,5W
-  75 wys. | 250 szer. | 250 g.
-  1,9

-  **4078** – plafon LED średni
-  LED (zintegrowany) / 230V / 3900 lm / 3000K | 1 x 32W
-  75 wys. | 350 szer. | 350 g.
-  3,4

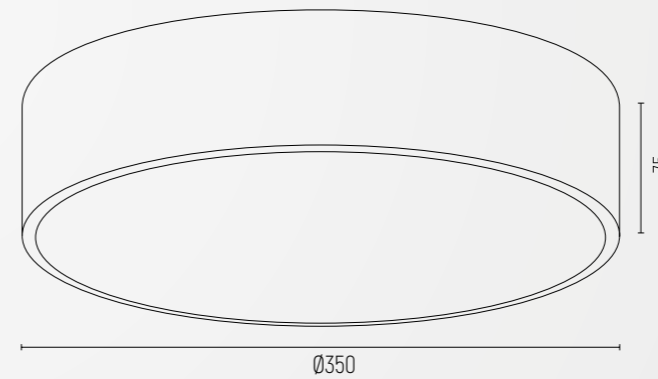
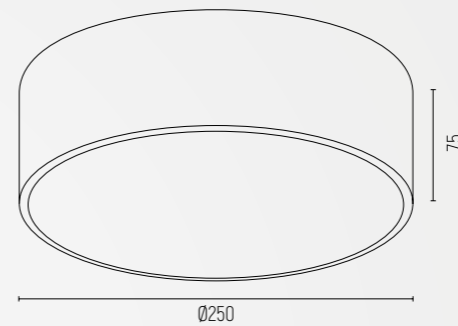

CLEVLAND

- 4692, 4702 - biały struktura
- 4691, 4703 - czarny struktura
- stal lakierowana
- IP 20

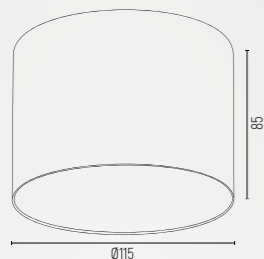

- 4692, 4691 - plafon 1 pt.
- GU10 LED AR111 / 230V / 3000K | 1 x 15W
- 85 wys. | 115 szer. | 115 gł.
- 0,25

oprawy na źródło światła GU10 AR111 oferujemy w wersji bez żarówki (indeks z końcówką BZ) lub z dedykowanym źródłem światła (żarówki GU10 AR111 moc 15W 3000K lub 4000K)

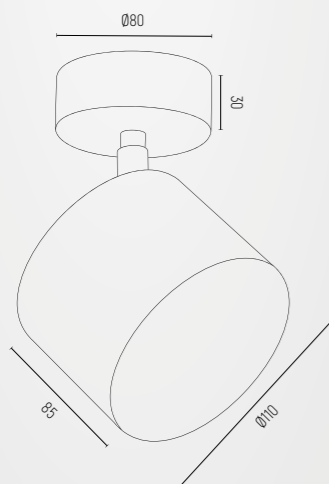

- 4702, 4703- reflektor 1 pt.
- GU10 LED AR111 / 230V / 3000K | 1 x 15W
- max 135 wys. | 110 szer. | max 160 gł.
- 0,5

możliwość regulacji, możliwość zamontowania na ścianie jako kinkiet, oprawy na źródło światła GU10 AR111 oferujemy w wersji bez żarówki (indeks z końcówką BZ) lub z dedykowanym źródłem światła (żarówki GU10 AR111 moc 15W 3000K lub 4000K)

CLEVLAND 4692



CLEVLAND 4691



CLEVLAND 4702



CLEVLAND 4703



CLEVLAND 1031



CLEVLAND 1032



CLEVLAND 6100



CLEVLAND 6101



CLEVLAND

- 1031, 6100- biały struktura
- 1032, 6101 - czarny struktura
- stal lakierowana
- IP 20

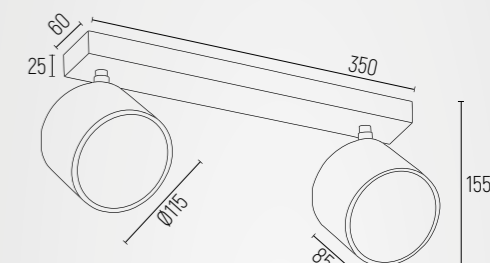

- 1031, 1032 - plafon 2 pt.
- GU10 LED AR111 / 230V / 3000K | 2 x 15W
- max 160 wys. | max 475 szer. | max 130 gł.
- 1,2

możliwość regulacji, możliwość zamontowania na ścianie jako kinkiet, oprawy na źródło światła GU10 AR111 oferujemy w wersji bez żarówki (indeks z końcówką BZ) lub z dedykowanym źródłem światła (żarówki GU10 AR111 moc 15W 3000K lub 4000K)

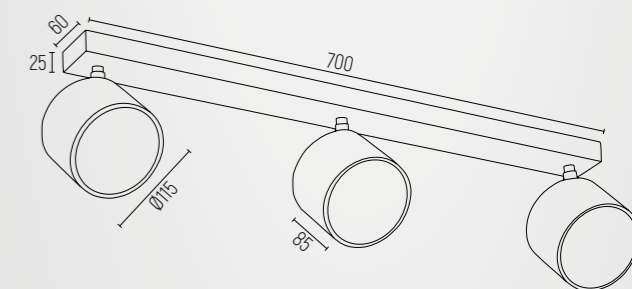

- 6100, 6101 - plafon 3 pt.
- GU10 LED AR111 / 230V / 3000K | 3 x 15W
- max 160 wys. | max 820 szer. | max 130 gł.
- 1,6

możliwość regulacji, możliwość zamontowania na ścianie jako kinkiet, oprawy na źródło światła GU10 AR111 oferujemy w wersji bez żarówki (indeks z końcówką BZ) lub z dedykowanym źródłem światła (żarówki GU10 AR111 moc 15W 3000K lub 4000K)

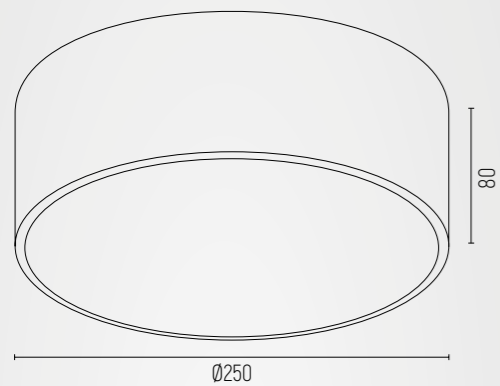

DARLING 3080



DARLING 3081



DARLING 3082



DARLING 871



DARLING 3083



DARLING 659



DARLING 661



DARLING 660



DARLING 872



DARLING 873

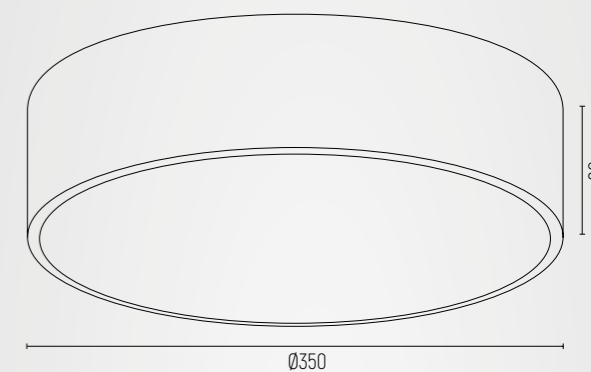

DARLING

- 3080 - ciemno-szary struktura
- 3081 - czarny struktura
- 3082 - biały struktura
- 871 - złoty struktura
- 3083 - chrom
- plafon 2 pł. mały
- 3080, 3081, 3082, 871 - stal lakierowana, szkło
3083 - stal chromowana, szkło
- E27 (nie zawiera źródła światła) / 230V | 2 x 15W (max)
- 80 wys. | 250 szer. | 250 g.
- 1,5
- IP 20

DARLING

- 659 - ciemno-szary struktura
- 661 - czarny struktura
- 660 - biały struktura
- 872 - złoty struktura
- 873 - chrom
- plafon 2 pł. średni
- 659, 661, 660, 872 - stal lakierowana, szkło
873 - stal chromowana, szkło
- E27 (nie zawiera źródła światła) / 230V | 2 x 15W (max)
- 80 wys. | 350 szer. | 350 g.
- 2,6
- IP 20

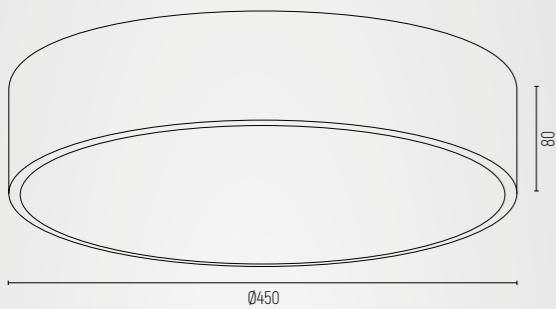

DARLING 1187



DARLING 2083



DARLING 1186



DARLING 2084

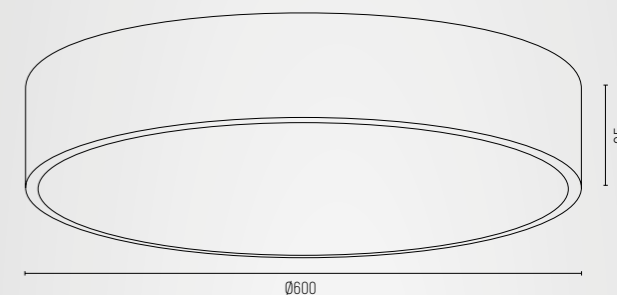

DARLING 1188

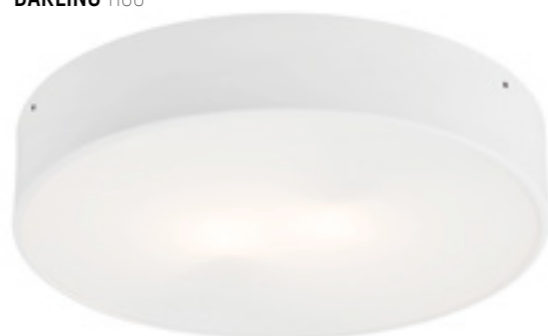

DARLING 2082



DARLING 1458



DARLING 2081



DARLING

- 1187 – ciemno-szary struktura
- 1186 – czarny struktura
- 1188 – biały struktura
- 1458 – złoty struktura
- plafon 3 pł. duży
- stal lakierowana, szkło
- E27 (nie zawiera źródła światła) / 230V | 3 x 15W (max)
- 80 wys. | 450 szer. | 450 gł.
- 3,2
- IP 20

DARLING

- 2083 – ciemno-szary struktura
- 2084 – czarny struktura
- 2082 – biały struktura
- 2081 – złoty struktura
- plafon 5 pł. XL
- stal lakierowana, plexi
- E27 (nie zawiera źródła światła) / 230V | 5 x 15W (max)
- 95 wys. | 600 szer. | 600 gł.
- 5
- IP 20

DARLING 2535



DARLING 2536



DARLING 2534



DARLING 2533



DARLING

● 2535 - ciemno-szary struktura

● 2536 - czarny struktura

○ 2534 - biały struktura

● 2533 - złoty struktura

⊕ plafon 6 pt. XXL

⊕ stal lakierowana, plexi

⊕ E27 (nie zawiera źródła światła) / 230V | 6 x 15W (max)

⊕ 95 wys. | 750 szer. | 750 gt.

⊕ 5,9

⊕ IP 20

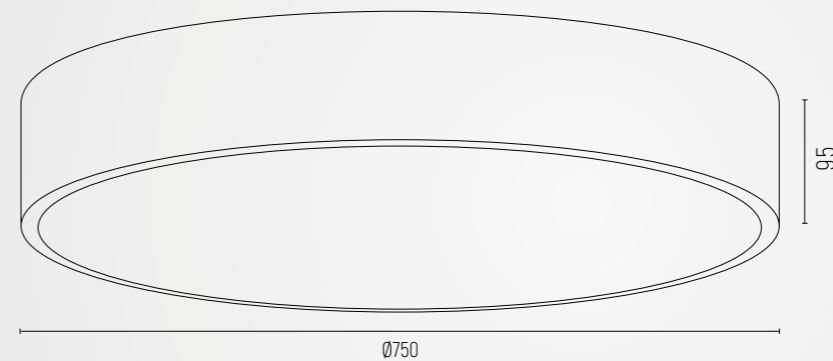

DARLING LED

- 3566, 3567 - biały struktura
- 3569, 3570 - czarny struktura
- stal lakierowana, szkło
- IP 20
- możliwość zastosowania modułu LED o temperaturze barwowej 4000K - nieodpłatnie

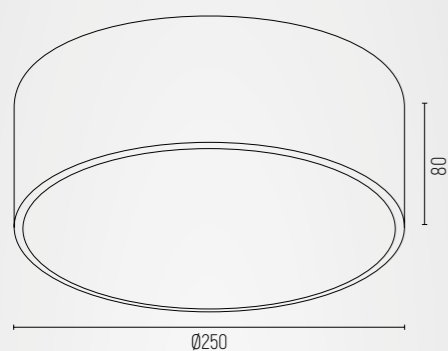

- 3566, 3569 - plafon mały led
- LED (zintegrowany) / 230V / 2450 lm / 3000K | 1 x 22,5W
- 80 wys. | 250 szer. | 250 g.
- 1,5

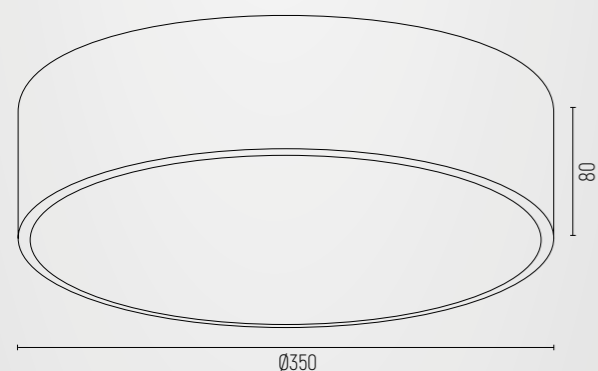

- 3567, 3570 - plafon średni led
- LED (zintegrowany) / 230V / 3900 lm / 3000K | 1 x 32W
- 80 wys. | 350 szer. | 350 g.
- 2,6

DARLING LED 3566



DARLING LED 3569



DARLING LED 3567



DARLING LED 3570



DARLING LED 3568



DARLING LED 3571



DARLING LED

- 3568 - biały struktura
- 3571 - czarny struktura
- plafon duży led
- stal lakierowana, szkło
- IP 20
- LED (zintegrowany) / 230V / 5380 lm / 3000K | 1 x 42W
- 80 wys. | 450 szer. | 450 g.
- 3,2
- możliwość zastosowania modułu LED o temperaturze barwowej 4000K - nieodpłatnie

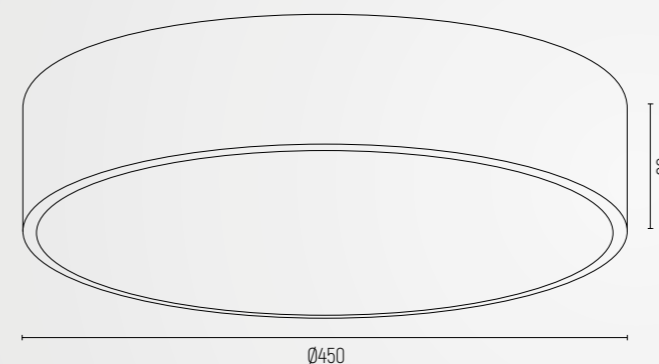

DARLING LED

- 3349, 3351 - biały struktura
- 3350, 3352 - czarny struktura
- 🔧 stal lakierowana, szkło
- 🛡️ IP 20
- ⊕ możliwość zastosowania modułu LED o temperaturze barwowej 4000K - nieodpłatnie

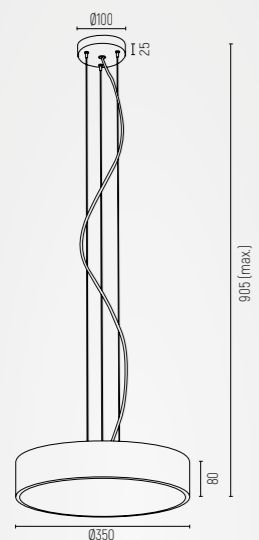

- 🔧 3349, 3350 lampa wisząca mała 1 pt. led
- 💡 LED (zintegrowany) / 230V / 3900 lm / 3000K | 1 x 32W
- 📏 905 (linka 800) wys. | 350 szer. | 350 g.
- 📊 2,8

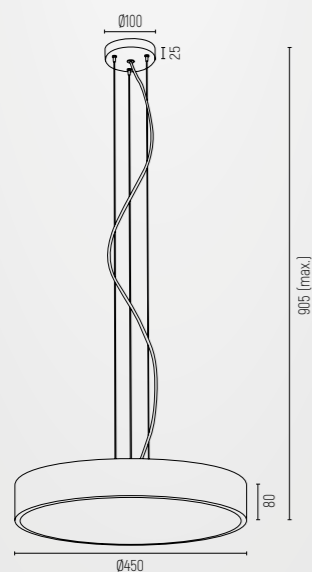

- 🔧 3351, 3352 lampa wisząca duża 1 pt. led
- 💡 LED (zintegrowany) / 230V / 5380 lm / 3000K | 1 x 42W
- 📏 905 (linka 800) wys. | 450 szer. | 450 g.
- 📊 3,4

DARLING LED 3349



DARLING LED 3350



DARLING LED 3351



DARLING LED 3352

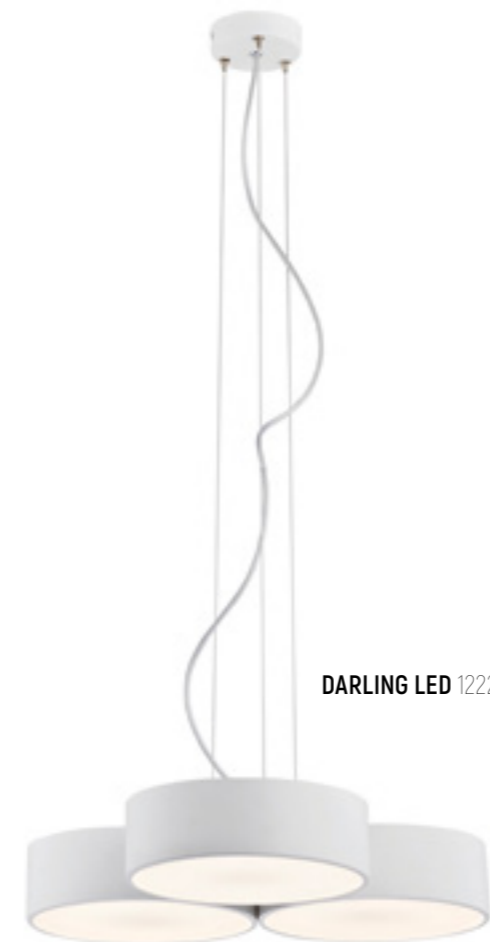

DARLING LED 1222

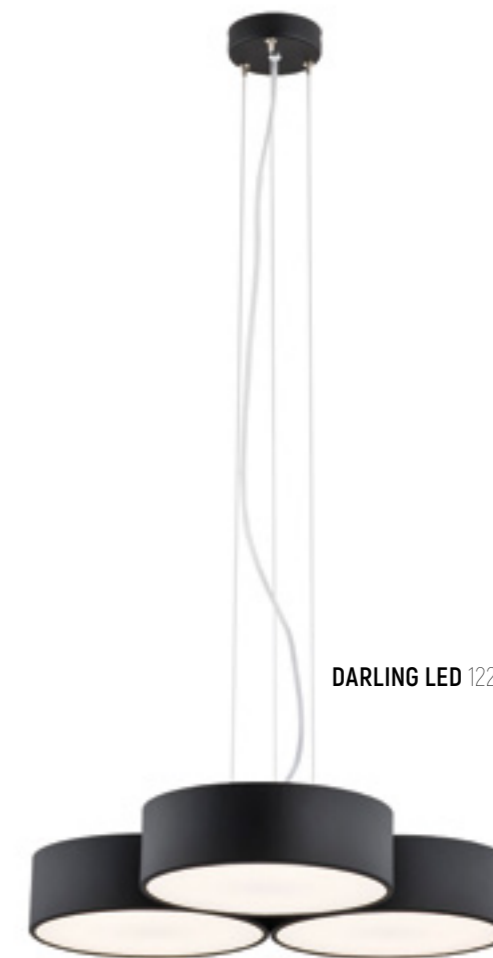

DARLING LED 1223

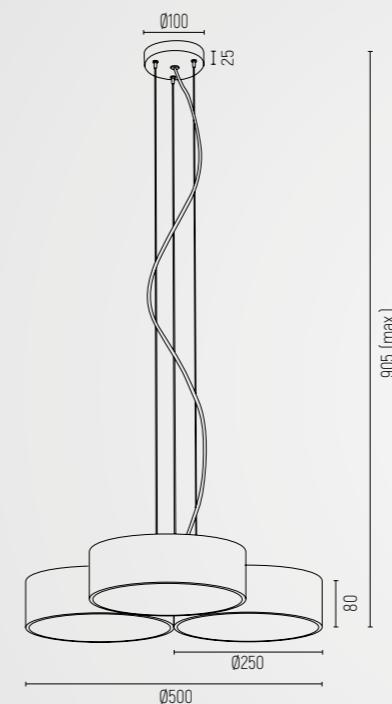

DARLING LED

- 1222 - biały struktura
- 1223 - czarny struktura
- 🔧 lampa wisząca 3 pt. led
- 🔧 stal lakierowana, szkło
- 💡 LED (zintegrowany) / 230V / 3x2450 lm / 3000K | 3 x 22,5W
- 📏 905 (linka 800) wys. | 500 [250 pojedynczy] szer. | 500 g.
- 📊 5,5
- 🛡️ IP 20
- ⊕ możliwość zastosowania modułu LED o temperaturze barwowej 4000K - nieodpłatnie

ESPRESSO

- 3302, 719 - biały struktura
- 3303, 720 - czarny struktura
- stal lakierowana
- IP 20
- możliwość regulacji kąta padania światła

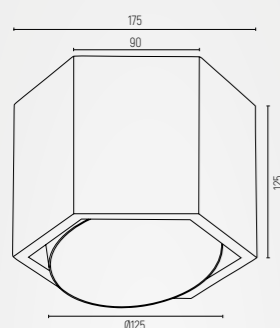

- 3302, 3303 - plafon 1 pt.
- G9 (nie zawiera źródła światła) / 230V | 1 x 6W LED (max)
- 125 wys. | 150 szer. | 175 gł.
- 0,9

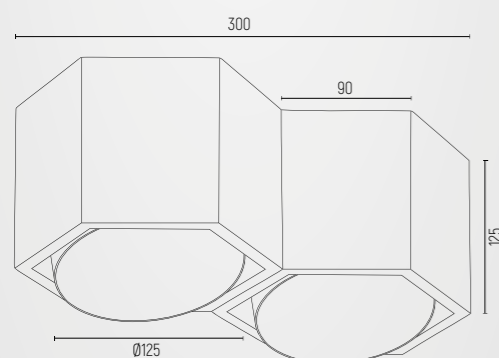

- 719, 720 - plafon 2 pt.
- G9 (nie zawiera źródła światła) / 230V | 2 x 6W LED (max)
- 125 wys. | 300 szer. | 175 gł.
- 1,9

ESPRESSO 3302



ESPRESSO 3303



ESPRESSO 719



ESPRESSO 720



ESPRESSO 1218



ESPRESSO 1219



ESPRESSO

- 1218 - biały struktura
- 1219 - czarny struktura
- plafon 3 pt.
- stal lakierowana
- G9 (nie zawiera źródła światła) / 230V | 3 x 6W LED (max)
- 125 wys. | 450 szer. | 175 gł.
- 2,9
- IP 20
- możliwość regulacji kąta padania światła

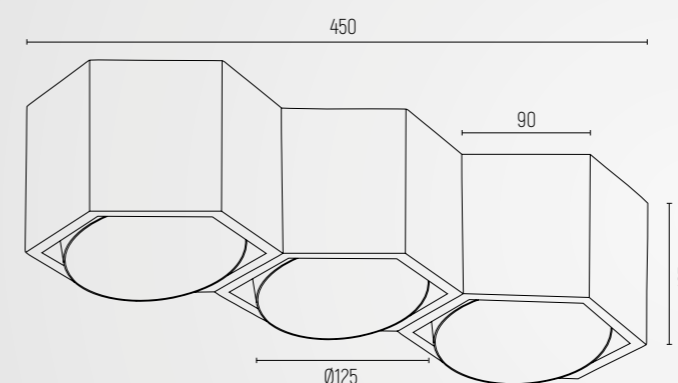

GARLAND 4710



GARLAND 4711









JASPER 1050



JASPER 1035



GARLAND

-  4710 - biały struktura
-  4711 - czarny struktura
-  plafon 1 pt.
-  stal lakierowana
-  GU10 LED AR111 / 230V / 3000K | 1 x 15W
-  145 wys. | 140 szer. | 140 gt.
-  0,9
-  IP 20
-  możliwość regulacji kąta padania światła, oprawy na źródło światła GU10 AR111 oferujemy w wersji bez żarówki (indeks z końcówką BZ) lub z dedykowanym źródłem światła (żarówki GU10 AR111 moc 15W 3000K lub 4000K)

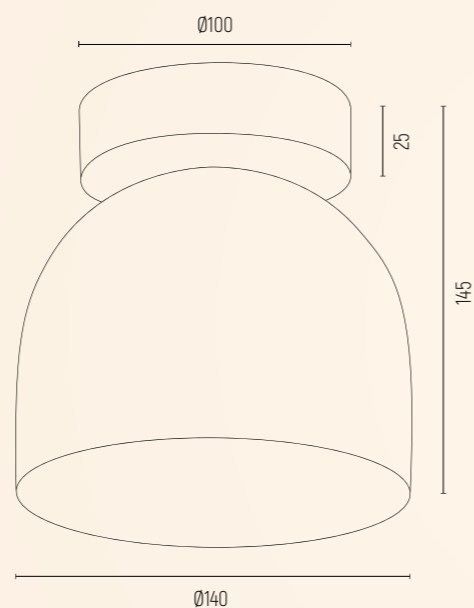

JASPER

-  1050 - czarny struktura, mosiądz
-  1035 - czarny struktura
-  kinkiet 2 pt.
-  1050 - stal lakierowana, stal mosiądzowana
1035 - stal lakierowana
-  G9 (nie zawiera źródła światła) / 230V + LED (zintegrowany) / 230V / 3000K | 1 x 6W LED (max) + 1 x 4,5W
-  max 180 wys. | 255 szer. | max 205 gt.
-  1
-  IP 20
-  możliwość regulacji kąta padania światła, możliwość skompletowania z kolekcjami ETNA, ETNA PLUS, SICILA, SICILIA PLUS, TORRE

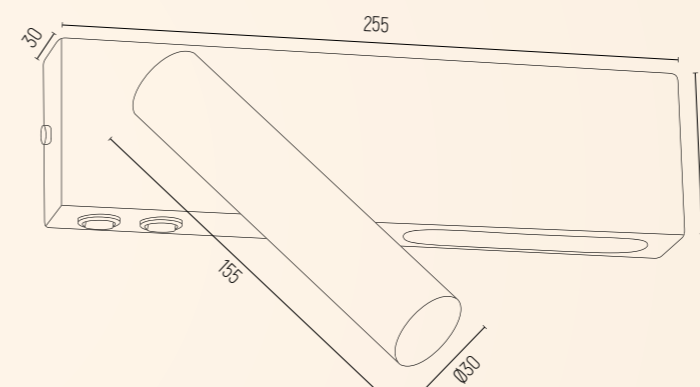

OLIMP PLUS

- 4745 - biały struktura
- 4746 - czarny struktura
- oprawa stropowa 1 pt.
- stal lakierowana
- GU10 LED AR111 / 230V / 3000K | 1 x 15W
- 80 wys. | 170*170 szer. | 80 g.
- 0,8
- IP 20

możliwość regulacji kąta padania światła, oprawy na źródło światła GU10 AR111 oferujemy w wersji bez żarówki (indeks z końcówką BZ) lub z dedykowanym źródłem światła (żarówki GU10 AR111 moc 15W 3000K lub 4000K)

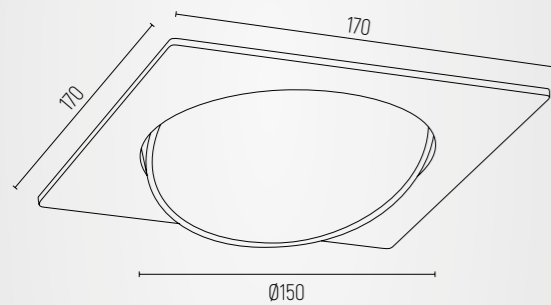

OLIMP

- 3654 - biały struktura
- 3656 - czarny struktura
- oprawa stropowa 1 pt.
- stal lakierowana
- G9 (nie zawiera źródła światła) / 230V | 1 x 6W LED (max)
- 80 wys. | 170*170 szer. | 80 g.
- 0,7
- IP 20
- możliwość regulacji kąta padania światła



OLIMP PLUS 4745



OLIMP PLUS 4746



OLIMP 3654



OLIMP 3656



OLIMP PLUS 1046



OLIMP PLUS 1047



OLIMP 785



OLIMP 787

OLIMP PLUS

- 1046 - biały struktura
- 1047 - czarny struktura
- oprawa stropowa 2 pt.
- stal lakierowana
- GU10 LED AR111 / 230V / 3000K | 2 x 15W
- 80 wys. | 340*170 szer. | 80 g.
- 1,9
- IP 20

możliwość regulacji kąta padania światła, oprawy na źródło światła GU10 AR111 oferujemy w wersji bez żarówki (indeks z końcówką BZ) lub z dedykowanym źródłem światła (żarówki GU10 AR111 moc 15W 3000K lub 4000K)

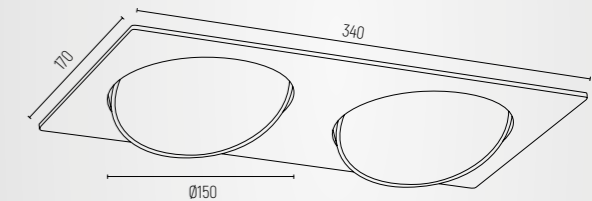

OLIMP

- 785 - biały struktura
- 787 - czarny struktura
- oprawa stropowa 2 pt.
- stal lakierowana
- G9 (nie zawiera źródła światła) / 230V | 2 x 6W LED (max)
- 80 wys. | 340*170 szer. | 80 g.
- 1,7
- IP 20
- możliwość regulacji kąta padania światła



OLIMP 1327



OLIMP PLUS 6115



OLIMP 1329



OLIMP PLUS 6116

OLIMP PLUS

- 6115 - biały struktura
- 6116 - czarny struktura
- oprawa stropowa 3 pt.
- 🏠 stal lakierowana
- 💡 GU10 LED AR111 / 230V / 3000K | 3 x 15W
- 📏 80 wys. | 510*170 szer. | 80 g.
- 📦 2,4
- 🛡️ IP 20

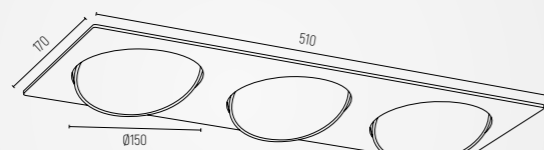

+ możliwość regulacji kąta padania światła, oprawy na źródło światła GU10 AR111 oferujemy w wersji bez żarówki (indeks z końcówką BZ) lub z dedykowanym źródłem światła (żarówki GU10 AR111 moc 15W 3000K lub 4000K)

OLIMP

- 1327 - biały struktura
- 1329 - czarny struktura
- oprawa stropowa 3 pt.
- 🏠 stal lakierowana
- 💡 G9 (nie zawiera źródła światła) / 230V | 3 x 6W LED (max)
- 📏 80 wys. | 510*170 szer. | 80 g.
- 📦 2,1
- 🛡️ IP 20
- + możliwość regulacji kąta padania światła

ONTARIO LED

- 3572, 3573, 3574 - biały struktura
- 3575, 3576, 3577 - czarny struktura
- 🏠 stal lakierowana, szkło
- 🛡️ IP 20
- + możliwość zastosowania modułu LED o temperaturze barwowej 4000K - nieodpłatnie

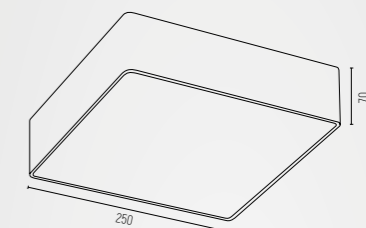

- 📏 3572, 3575 - plafon mały led
- 💡 LED (zintegrowany) / 230V / 4500 lm / 3000K | 1 x 18,5W
- 📏 70 wys. | 250 szer. | 250 g.
- 📦 1,9

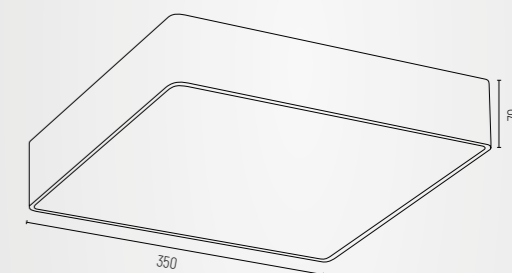

- 📏 3573, 3576 - plafon średni led
- 💡 LED (zintegrowany) / 230V / 3900 lm / 3000K | 1 x 32W
- 📏 70 wys. | 350 szer. | 350 g.
- 📦 3,4

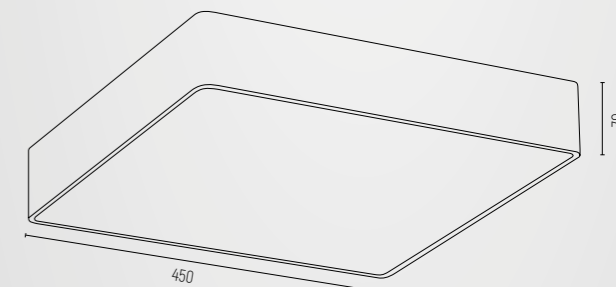

- 📏 3574, 3577 - plafon duży led
- 💡 LED (zintegrowany) / 230V / 4500 lm / 3000K | 1 x 40,5W
- 📏 70 wys. | 450 szer. | 450 g.
- 📦 5,4

ONTARIO LED 3572



ONTARIO LED 3575



ONTARIO LED 3573



ONTARIO LED 3576



ONTARIO LED 3574



ONTARIO LED 3577



ONTARIO

- 652, 1579 - biały struktura
- 653, 1578 - ciemno-szary struktura
- 654, 1580 - czarny struktura
- stal lakierowana, szkło
- IP 20

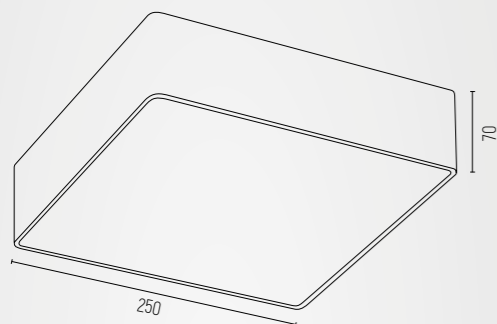

- 652, 653, 654 - plafon 2 pt. mały
- E27 (nie zawiera źródła światła) / 230V | 2 x 15W (max)
- 70 wys. | 250 szer. | 250 gł.
- 1,9

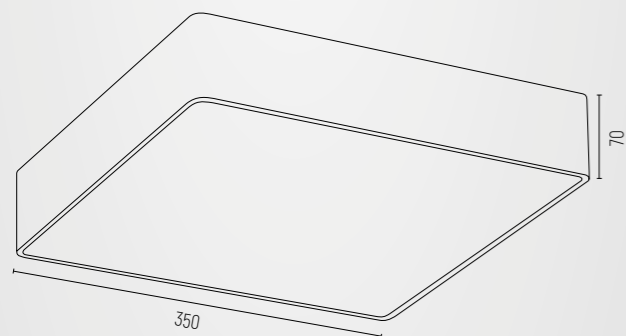

- 1579, 1578, 1580 - plafon 4 pt. średni
- E27 (nie zawiera źródła światła) / 230V | 4 x 15W (max)
- 70 wys. | 350 szer. | 350 gł.
- 3,4

ONTARIO 652



ONTARIO 653



ONTARIO 654



ONTARIO 1579



ONTARIO 1578



ONTARIO 1580



ONTARIO 1576



ONTARIO 1575



ONTARIO 1577



ONTARIO

- 1576 - biały struktura
- 1575 - ciemno-szary struktura
- 1577 - czarny struktura
- plafon 4 pt. duży
- stal lakierowana, szkło
- E27 (nie zawiera źródła światła) / 230V | 4 x 15W (max)
- 70 wys. | 450 szer. | 450 gł.
- 5,4
- IP 20

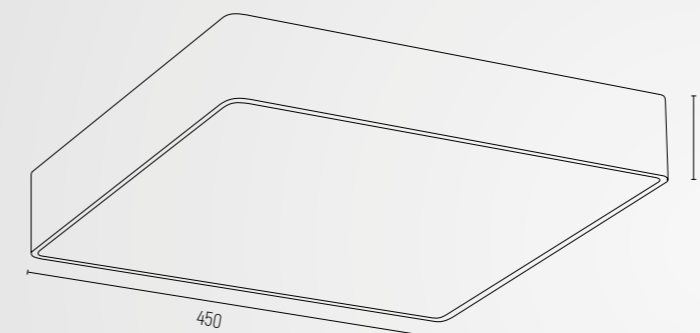

ROCK 4730



ROCK 4723



ROCK 4737



ROCKSTAR 4758



ROCKSTAR 4743

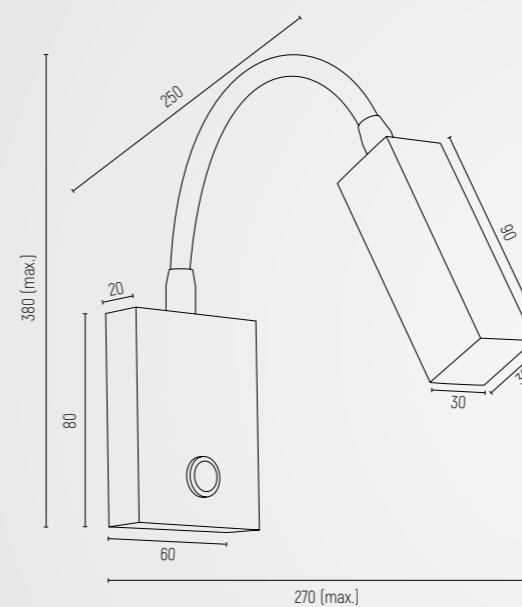
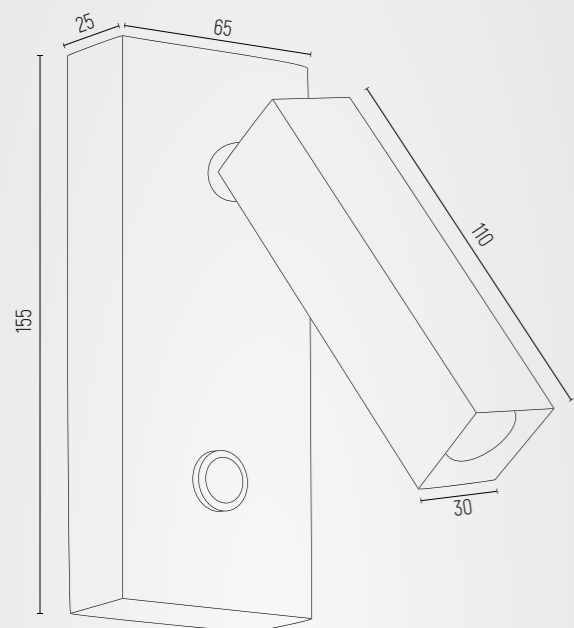

ROCK

- 4730 - biały struktura
- 4723 - czarny struktura
- 4737 - mosiądz szczotkowany
- kinkiet 1 pt.
- stal lakierowana | mosiądz
- G9 (nie zawiera źródła światła) / 230V | 1 x 6W LED (max)
- 155 wys. | 65 szer. | 135 gł.
- 0,6
- IP 20
- możliwość regulacji kąta padania światła

ROCKSTAR

- 4758 - czarny struktura
- 4743 - mosiądz szczotkowany
- kinkiet 1 pt.
- stal lakierowana | mosiądz
- G9 (nie zawiera źródła światła) / 230V | 1 x 6W LED (max)
- 380 max wys. | 60 szer. | 270 max gł.
- 0,4
- IP 20
- możliwość regulacji kąta padania światła

RODOS PLUS

○ 4753, 1048 - biały struktura

● 4754, 1049 - czarny struktura

☰ stal lakierowana

Ⓜ IP 20

⊕ możliwość regulacji kąta padania światła, oprawy na źródło światła GU10 AR111 oferujemy w wersji bez żarówki [indeks z końcówką BZ] lub z dedykowanym źródłem światła (żarówki GU10 AR111 moc 15W 3000K lub 4000K)

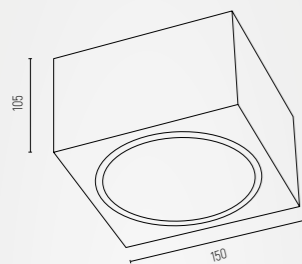

☰ 4753, 4754 - plafon 1 pt.

💡 GU10 LED AR111 / 230V / 3000K | 1 x 15W

☰ 105 wys. | 150 szer. | 150 g.

Ⓜ 0,9

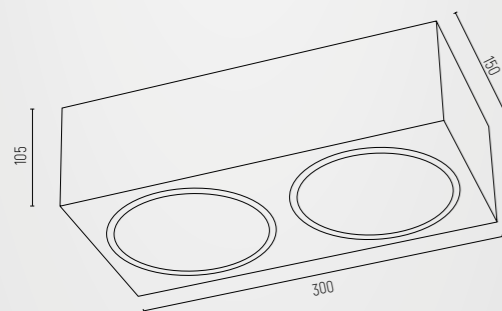

☰ 1048, 1049 - plafon 2 pt.

💡 GU10 LED AR111 / 230V / 3000K | 2 x 15W

☰ 105 wys. | 300 szer. | 150 g.

Ⓜ 1,5



RODOS PLUS 4753



RODOS PLUS 4754



RODOS PLUS 1048



RODOS PLUS 1049



RODOS PLUS 6117



RODOS PLUS 6118



RODOS PLUS 1744



RODOS PLUS 1745

RODOS PLUS

○ 6117, 1744 - biały struktura

● 6118, 1745 - czarny struktura

☰ stal lakierowana

Ⓜ IP 20

⊕ możliwość regulacji kąta padania światła, oprawy na źródło światła GU10 AR111 oferujemy w wersji bez żarówki [indeks z końcówką BZ] lub z dedykowanym źródłem światła (żarówki GU10 AR111 moc 15W 3000K lub 4000K)

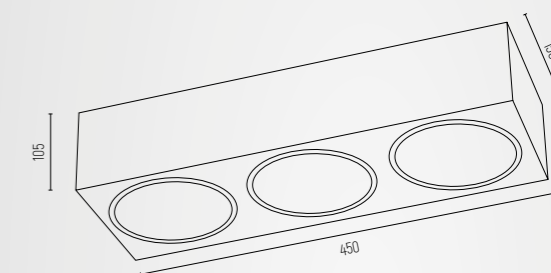

☰ 6117, 6118 - plafon 3 pt.

💡 GU10 LED AR111 / 230V / 3000K | 3 x 15W

☰ 105 wys. | 450 szer. | 150 g.

Ⓜ 2,1

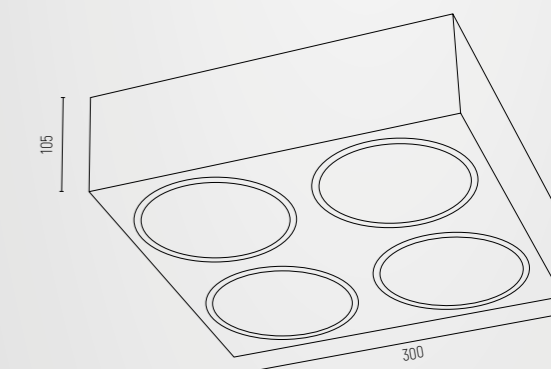

☰ 1744, 1745 - plafon 4 pt.

💡 GU10 LED AR111 / 230V / 3000K | 4 x 15W

☰ 105 wys. | 300 szer. | 300 g.

Ⓜ 2,6

RODOS

- 263, 581 - biały struktura
- 346, 617 - czarny struktura
- stal lakierowana
- IP 20
- możliwość regulacji kąta padania światła

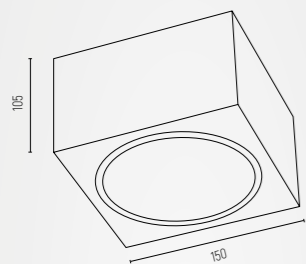

- 263, 346 - plafon 1 pt.
- G9 (nie zawiera źródła światła) / 230V | 1 x 6W LED (max)
- 105 wys. | 150 szer. | 150 g.
- 0,8

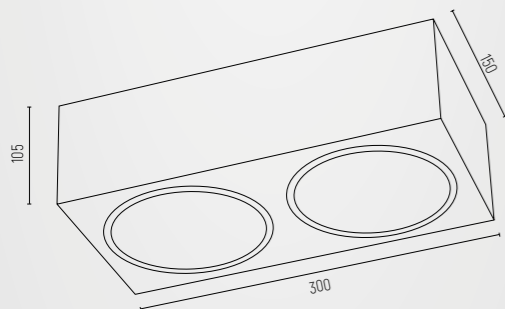

- 581, 617 - plafon 2 pt.
- G9 (nie zawiera źródła światła) / 230V | 2 x 6W LED (max)
- 105 wys. | 300 szer. | 150 g.
- 1,3



RODOS 263



RODOS 346



RODOS 581



RODOS 617



RODOS 1088



RODOS 1119



RODOS 1540



RODOS 1553

RODOS

- 1088, 1540 - biały struktura
- 1119, 1553 - czarny struktura
- stal lakierowana
- IP 20
- możliwość regulacji kąta padania światła

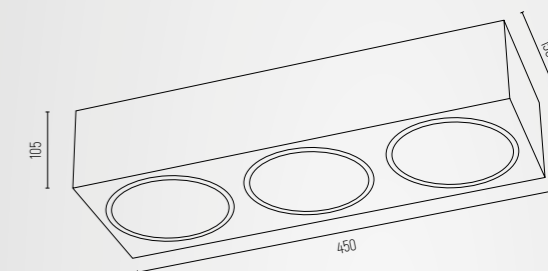

- 1088, 1119 - plafon 3 pt.
- G9 (nie zawiera źródła światła) / 230V | 3 x 6W LED (max)
- 105 wys. | 450 szer. | 150 g.
- 1,8

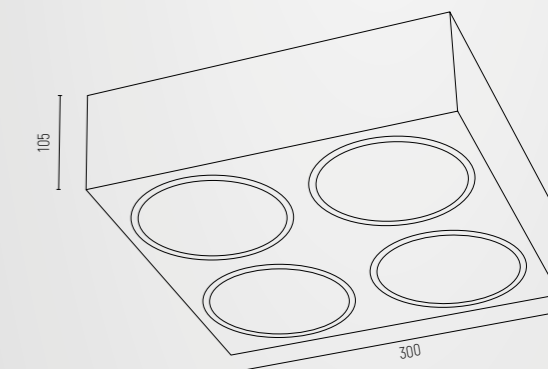

- 1540, 1553 - plafon 4 pt.
- G9 (nie zawiera źródła światła) / 230V | 4 x 6W LED (max)
- 105 wys. | 300 szer. | 300 g.
- 2,2

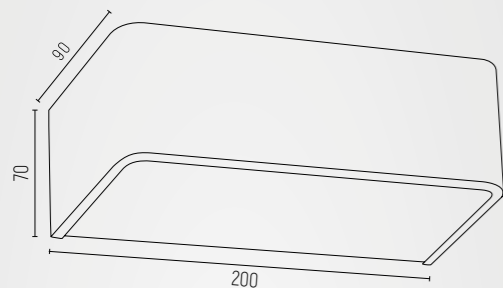

RODAN 3076



RODAN 3074



RODAN 3077



RODAN 3072



RODAN 3079



RODAN 3075



RODAN 3078



RODAN 3073



RODAN 4147



RODAN 4148

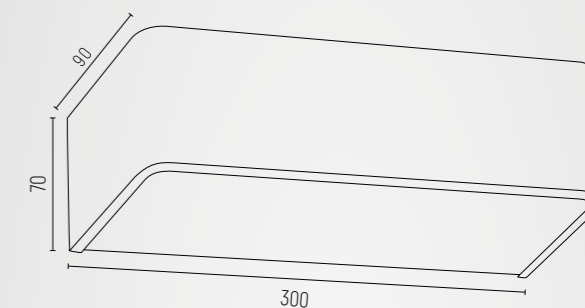

RODAN

- 3076 - chrom
- 3077 - biały struktura
- 3079 - czarny struktura
- 3078 - ciemno-szary struktura
- 4147 - złoty połysk, białe wykończenie
- kinkiet 1 pt. mały
- 3076 - stal chromowana, szkło
3077, 3079, 3078 - stal lakierowana, szkło
4147 - stal lakierowana, formatka, szkło
- E27 (nie zawiera źródła światła) / 230V | 1 x 15W (max)
- 70 wys. | 200 szer. | 90 gł.
- 0,8
- IP 20
- kinkiety Rodan występują w trzech różnych wielkościach oraz w pięciu kolorach: chrom, biały, czarny, ciemno-szary i mosiądz

RODAN

- 3074 - chrom
- 3072 - biały struktura
- 3075 - czarny struktura
- 3073 - ciemno-szary struktura
- 4148 - złoty połysk, białe wykończenie
- kinkiet 1 pt. średni
- 3074 - stal chromowana, szkło
3072, 3075, 3073 - stal lakierowana, szkło
4148 - stal lakierowana, formatka, szkło
- E27 (nie zawiera źródła światła) / 230V | 1 x 15W (max)
- 70 wys. | 300 szer. | 90 gł.
- 1,1
- IP 20
- kinkiety Rodan występują w trzech różnych wielkościach oraz w pięciu kolorach: chrom, biały, czarny, ciemno-szary i mosiądz

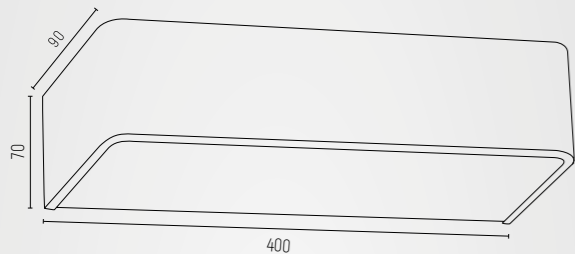

RODAN 655



RODAN 656



RODAN 657

















RODAN 658



RODAN 874

RODAN

-  655 - chrom
-  656 - biały struktura
-  657 - czarny struktura
-  658 - ciemno-szary struktura
-  874 - złoty połysk, białe wykończenie
-  kinkiet 2 pt. duży
-  655 - stal chromowana, szkło
-  656, 657, 658 - stal lakierowana, szkło
-  874 - stal lakierowana, formatka, szkło
-  E27 (nie zawiera źródła światła) / 230V | 2 x 15W (max)
-  70 wys. | 400 szer. | 90 gł.
-  1,4
-  IP 20
-  kinkiety Rodan występują w trzech różnych wielkościach oraz w pięciu kolorach: chrom, biały, czarny, ciemno-szary i mosiądz



TONI 903



TONI 904



TONI 905



TONI 906



TONI 907



TONI 908

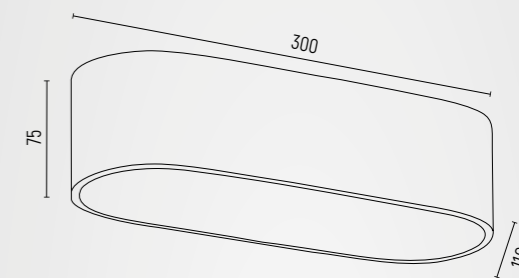

TONI

-  903 - mleczny, czarny struktura
-  904 - mleczny, czarny struktura ze złotym paskiem
-  905 - mleczny, biały struktura
-  906 - mleczny, biały struktura ze złotym paskiem
-  907 - mleczny, chrom
-  908 - mleczny, złoty struktura
-  plafon 2 pt.
-  plexi, stal lakierowana
-  E27 (nie zawiera źródła światła) / 230V | 2 x 15W (max)
-  75 wys. | 300 szer. | 110 gł.
-  1,5
-  IP 20



TONI 6000



TONI 6001



TONI 6002



TONI 6003



TONI 6004



TONI 6005

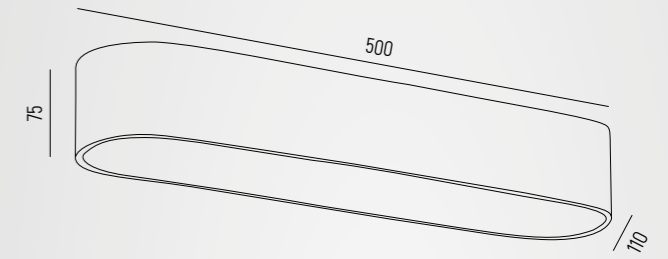

TONI

-  6000 – mleczny, czarna struktura
-  6001 – mleczny, czarna struktura ze złotym paskiem
-  6002 – mleczny, biała struktura
-  6003 – mleczny, biała struktura ze złotym paskiem
-  6004 – mleczny, chrom
-  6005 – mleczny, złoty struktura
-  plafon 3 pł.
-  plexi, stal lakierowana
-  E27 (nie zawiera źródła światła) / 230V | 3 x 15W (max)
-  75 wys. | 500 szer. | 110 gł.
-  2,2
-  IP 20

TUBO 4909



TUBO 4910







TYBER PLUS 4759





TYBER PLUS 4761

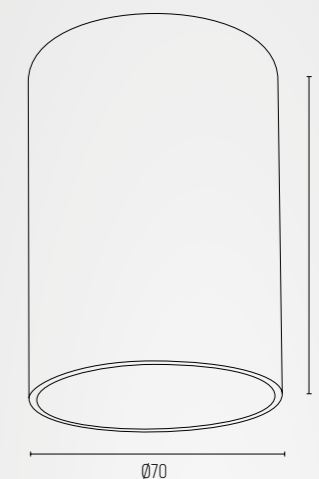

TYBER PLUS

-  4759, 4761 - mosiądz
-  stal mosiądzowana
-  GU10 (nie zawiera źródła światła) / 230V | 1 x 5W (max)
-  IP 20











-  4759 - plafon 1 pt.
-  110 wys. | 70 szer. | 70 gł.
-  0,3



-  4761 - plafon 1 pt.
-  180 wys. | 55 szer. | 55 gł.
-  0,4







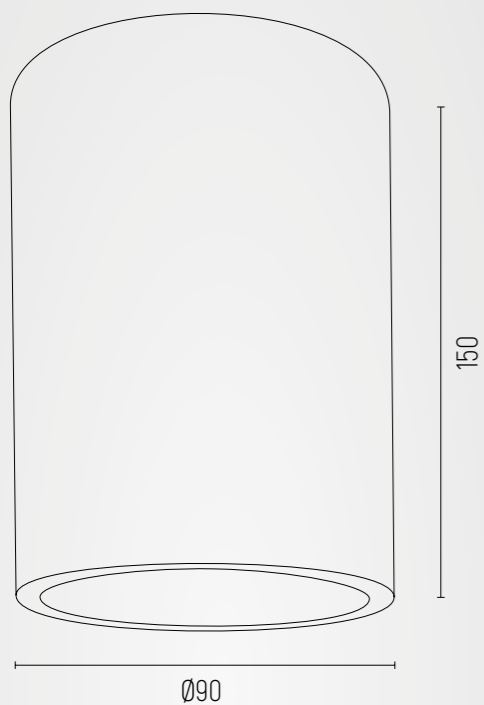



TUBO

-  4909 - czarny struktura
-  4910 - biały struktura
-  plafon 1 pt.
-  aluminium lakierowane
-  GU10 LED AR111 / 230V / 3000K | 1 x 15W (max)
-  185 wys. | 120 szer. | 120 gł.
-  0,6
-  IP 20
-  oprawy na źródło światła GU10 AR111 oferujemy w wersji bez żarówki (indeks z końcówką BZ) lub z dedykowanym źródłem światła (żarówki GU10 AR111 moc 15W 3000K lub 4000K)





TYBER

-  473 - srebrny struktura
-  474 - czarny struktura
-  475 - biały struktura
-  3108 - szary struktura
-  aluminium lakierowane
-  plafon 1 pt. okrągły
-  E27 (nie zawiera źródła światła) / 230V | 1 x 15W (max)
-  150 wys. | 90 szer. | 90 gt.
-  0,5
-  IP 20



TYBER 473



TYBER 474



TYBER 475



TYBER 3108



TYBER 3117



TYBER 3118









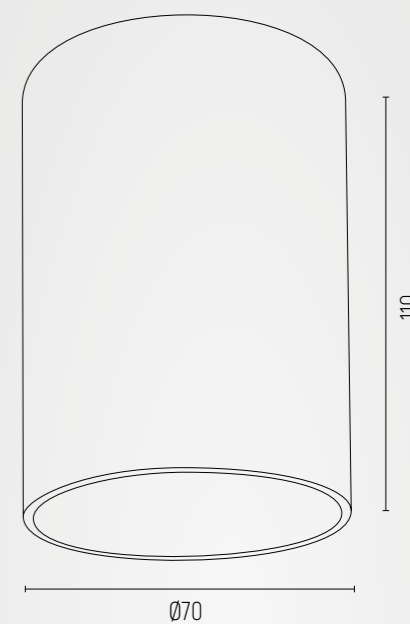



TYBER 3119



TYBER 3120



TYBER

-  3117 - srebrny struktura
-  3118 - czarny struktura
-  3119 - biały struktura
-  3120 - szary struktura
-  aluminium lakierowane
-  plafon 1 pt. okrągły
-  GU10 (nie zawiera źródła światła) / 230V | 1 x 5W (max)
-  110 wys. | 70 szer. | 70 gt.
-  0,2
-  IP 20

VICHY

- 3884, 3885 - biały struktura
- 3886, 3887 - czarny struktura
- 🏠 stal lakierowana, szkło
- 📏 IP 20
- ⊕ możliwość zastosowania modułu LED o temperaturze barwowej 4000K - nieodpłatnie

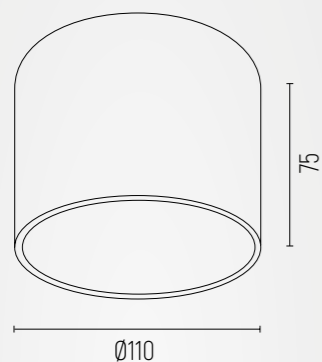

VICHY 3884



VICHY 3886



VICHY 3885



VICHY 3887

- 📏 3884, 3886 - plafon 1 pt. S
- 💡 LED (zintegrowany) 230V / 1150 lm / 3000 K | 9W
- 📏 75 wys. | 110 szer. | 110 g.
- 📏 1,1

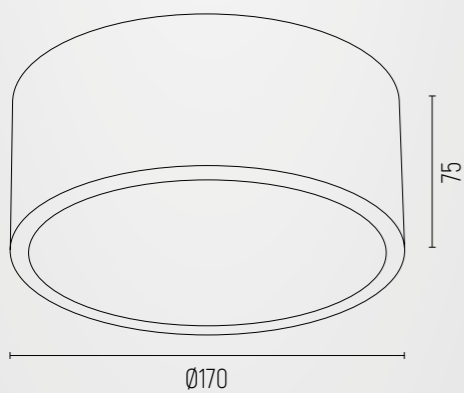

- 📏 3885, 3887 - plafon 1 pt. M
- 💡 LED (zintegrowany) 230V / 1690 lm / 3000 K | 13,5W
- 📏 75 wys. | 170 szer. | 170 g.
- 📏 1,8

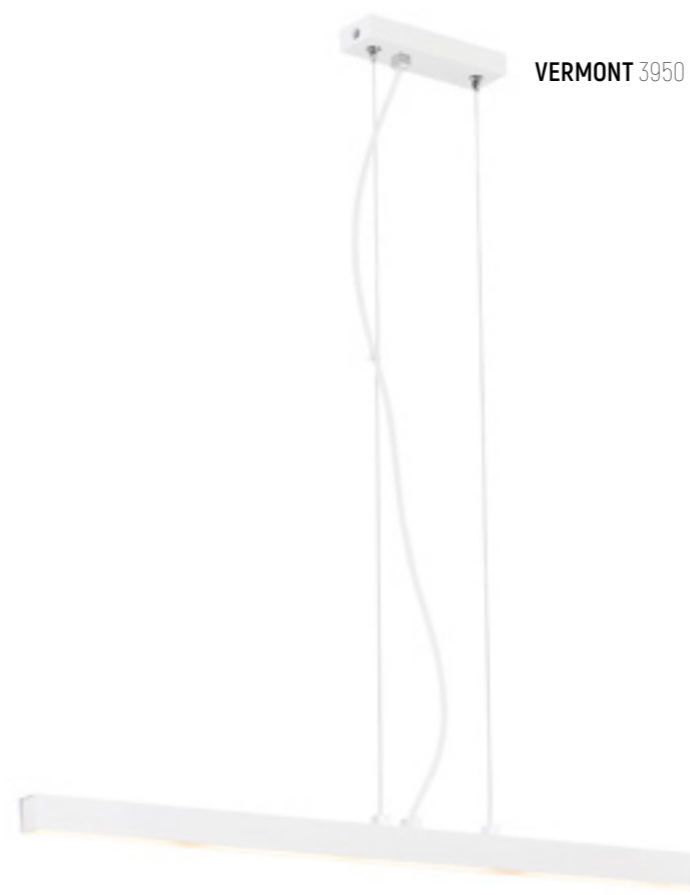

VERMONT 3950



VERMONT 3951

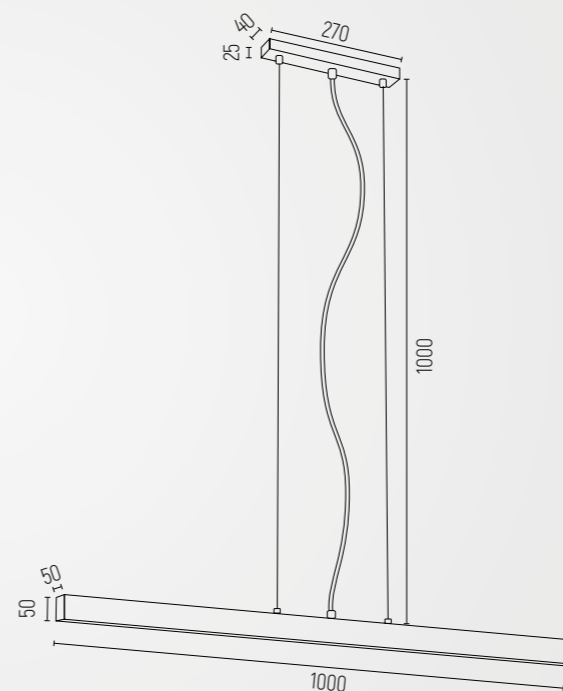

VERMONT

- 3950 - biały struktura
- 3951 - czarny struktura
- 💡 lampa wisząca
- 🏠 stal lakierowana
- 💡 LED (zintegrowany) 230V / 1440 lm / 3000 K | 1 x 18W
- 📏 1075 wys. | 1000 szer. | 50 g.
- 📏 2,3
- 📏 IP 20
- ⊕ możliwość zastosowania modułu LED o temperaturze barwowej 4000K - nieodpłatnie

ALTO 4749



ALTO 4750



ALTO 4751

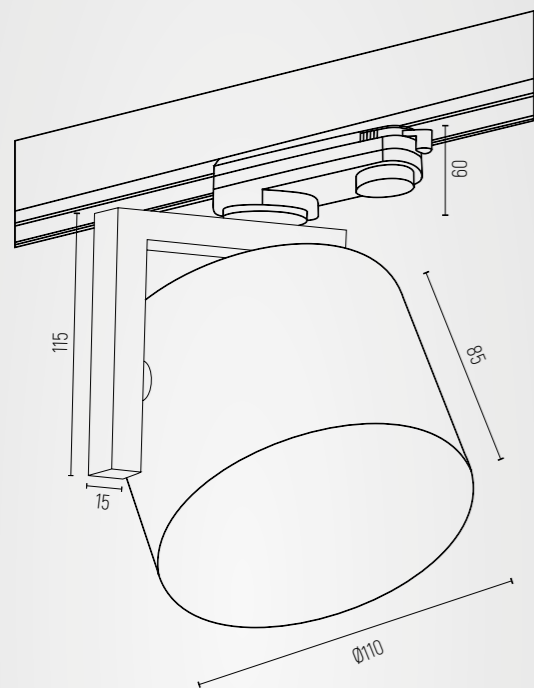

ALTO

- 4749 - błękit mat, czarny
- 4750 - biały struktura, czarny
- 4751 - czarny struktura, czarny
- reflektor 1 pt.
- stal lakierowana, tworzywo sztuczne
- GU10 LED AR111 / 230V / 3000K | 1 x 15W (max)
- 115 (175 z adapterem) wys. | 110 szer. | 115 g.
- 0,6
- IP 20

możliwość regulacji, w komplecie z adapterem umożliwiającym montaż do szyny, oprawy na źródło światła GU10 AR111 oferujemy w wersji bez żarówki (indeks z końcówką BZ) lub z dedykowanym źródłem światła (żarówki GU10 AR111 moc 15W 3000K lub 4000K)

BANG 4307



BANG 4308

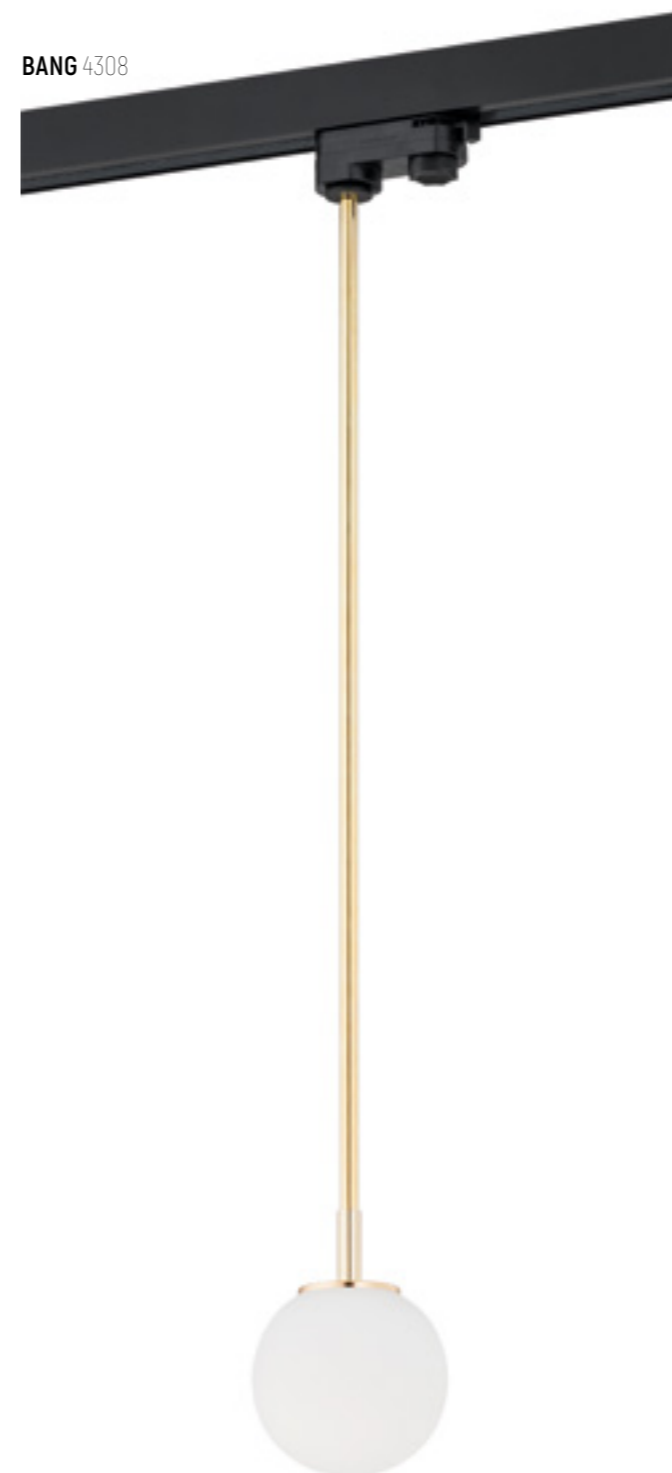

BANG

- opal mat, miedz, czarny
- szkło, stal miedzowana, tworzywo sztuczne
- G9 (nie zawiera źródła światła) / 230V | 1 x 6W (max)
- IP 20

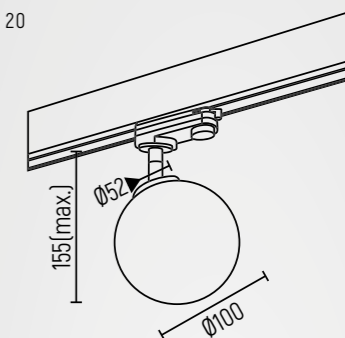

- 4307 - reflektor 1 pt.
- 155 (215 z adapterem) wys. | 100 (max 120) szer. | 100 g.
- 0,35
- możliwość regulacji, w komplecie z adapterem umożliwiającym montaż do szyny

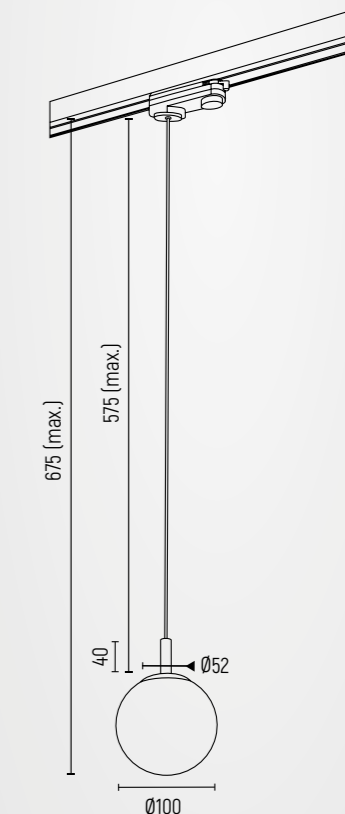

- 4308 - zwis 1 pt.
- 675 (735 z adapterem) wys. | 100 szer. | 100 g.
- 0,4
- w komplecie z adapterem umożliwiającym montaż do szyny.

UWAGA możliwość wyboru DŁUGOŚCI RURKI - 30 - 60 - 90 CM - CENA standard; możliwość zmiany standardowej długości rurki - cena ustalana wówczas indywidualnie

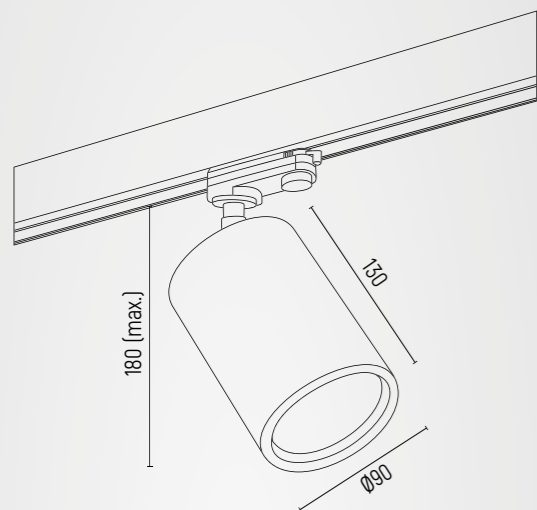

BERGEN 4304



BERGEN 4305



BERGEN 4306



BERGEN

-  4304 - złoty struktura, czarny
-  4305 - biały struktura, czarny
-  4306 - czarny struktura, czarny
-  reflektor 1 pt.
-  stal lakierowana, tworzywo sztuczne
-  E27 (nie zawiera źródła światła) / 230V | 1 x 15W (max)
-  180 (240 z adapterem) wys. | 90 szer. | 90 gł.
-  0,6
-  IP 20
-  w komplecie z adapterem umożliwiającym montaż do szyny





DELFI 4303







DELFI 4318



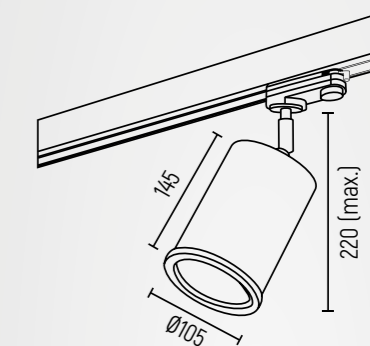



DELFI

-  złoty, czarny struktura, czarny
-  abażur, stal lakierowana, tworzywo sztuczne
-  E27 (nie zawiera źródła światła) / 230V | 1 x 15W (max)
-  IP 20
-  w komplecie z adapterem umożliwiającym montaż do szyny/możliwość regulacji

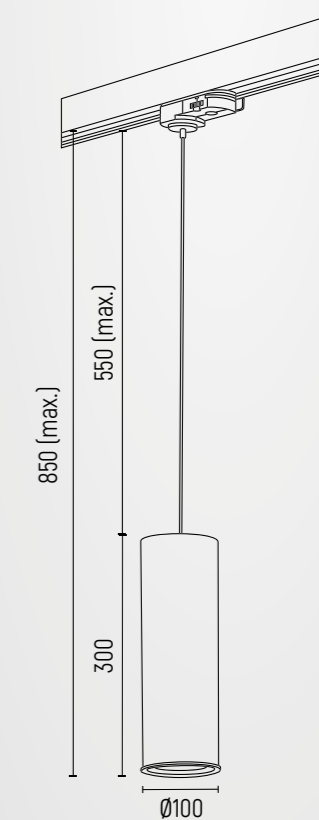

-  4303 - reflektor 1 pt.
-  220 (280 z adapterem) wys. | 105 szer. | 145 gł.
-  0,35



-  4318 - zwis 1 pt.
-  850 (910 z adapterem) wys. | 100 szer. | 100 gł.
-  0,5









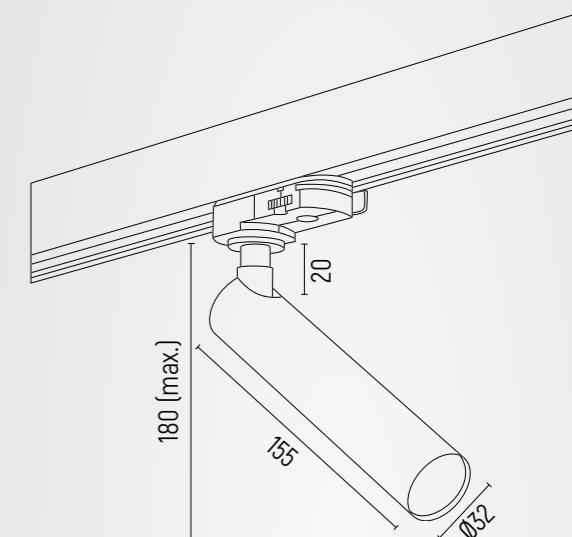

ELBRUS 4353



ELBRUS 4354



ELBRUS

-  4319 - mosiądz, czarny
-  4320 - czarny struktura, czarny
-  4330 - biały struktura, czarny
-  zwis 1 pt. LED
-  4319 - stal mosiądzowana, tworzywo sztuczne
4320, 4330 - stal lakierowana, tworzywo sztuczne
-  LED (zintegrowany) / 230V / 560 lm / 3000 K | 1 x 4,5W
-  950 (1010 z adapterem) wys. | 32 szer. | 32 gł.
-  0,45
-  IP 20

 w komplecie z adapterem umożliwiającym montaż do szyny/możliwość zastosowania modułu LED o temperaturze barwowej 4000K - nieodpłatnie, możliwość skompletowania z kolekcjami ETNA, ETNA PLUS, SICILIA, SICILIA PLUS, TORRE, JASPER

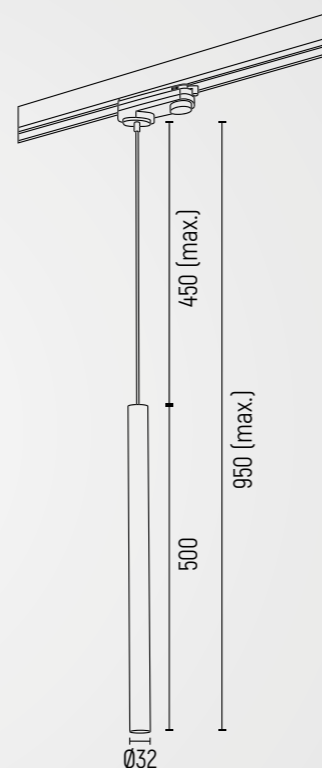

ELBRUS 4355



ELBRUS

-  4353 - biały struktura, czarny
-  4354 - mosiądz, czarny
-  4355 - czarny struktura, czarny
-  reflektor LED
-  4354 - stal mosiądzowana, tworzywo sztuczne
4353, 4355 - stal lakierowana, tworzywo sztuczne
-  LED (zintegrowany) / 230V / 560 lm / 3000 K | 1 x 4,5W
-  180 (240 z adapterem) wys. | 32 szer. | 32 gł.
-  0,2
-  IP 20

 w komplecie z adapterem umożliwiającym montaż do szyny/możliwość zastosowania modułu LED o temperaturze barwowej 4000K - nieodpłatnie/możliwość regulacji, możliwość skompletowania z kolekcjami ETNA, ETNA PLUS, SICILIA, SICILIA PLUS, TORRE, JASPER

HORTA 4327









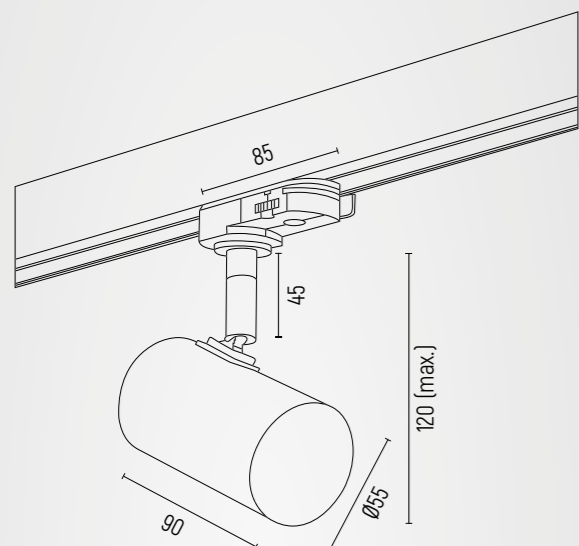

HORTA 4328



HORTA 4329



HORTA

-  4327 - biały struktura, czarny
-  4328 - mosiądz, czarny
-  4329 - czarny struktura, czarny
-  reflektor 1 pt.
-  4328 - stal mosiądzowana, tworzywo sztuczne
4327, 4329 - stal lakierowana, tworzywo sztuczne
-  GU10 (nie zawiera źródła światła) / 230V | 1 x 5W (max)
-  120 (180 z adapterem) wys. | 55 szer. | 90 gł.
-  0,4
-  IP 20
-  w komplecie z adapterem umożliwiającym montaż do szyny/możliwość regulacji

MURI 4377









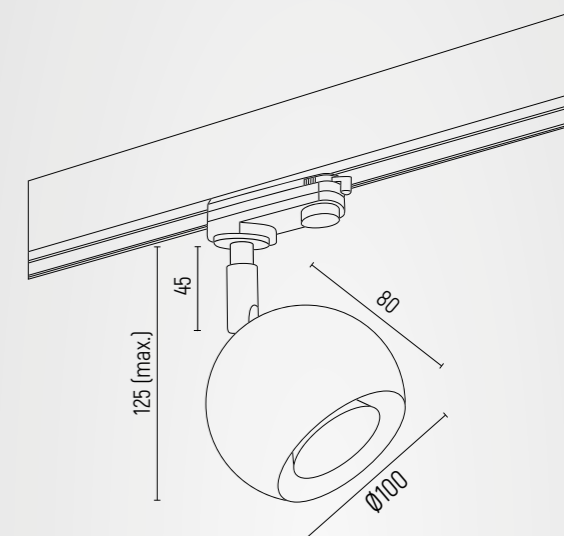



MURI 4378



MURI 4379



MURI

-  4377 - biały struktura, czarny
-  4379 - czarny struktura, czarny
-  4378 - mosiądz, czarny
-  reflektor 1 pt.
-  4377, 4379 - stal lakierowana, tworzywo sztuczne
4378 - stal mosiądzowana, tworzywo sztuczne
-  E27 (nie zawiera źródła światła) / 230V | 1 x 15W (max)
-  125 (185 z adapterem) wys. | 100 szer. | 100 gł.
-  0,5
-  IP 20
-  w komplecie z adapterem umożliwiającym montaż do szyny/możliwość regulacji

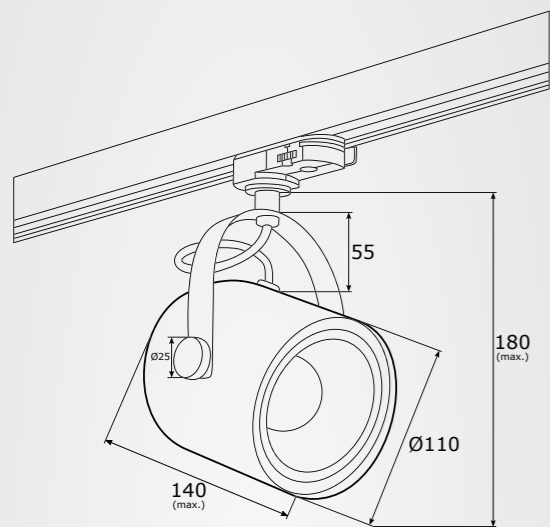

NET NET PLUS

- 4309** - biały struktura, czarny struktura, czarny
- 4310** - szalwia struktura, czarny struktura, czarny
- 4311** - czarny struktura, el. mosiądzowane, czarny
- 4747** - błękit mat, czarny
- reflektor 1 pt.
- 4309, 4310, 4747** - stal lakierowana, tworzywo sztuczne
4311 - stal lakierowana, el. mosiądzowane, tworzywo sztuczne
- E27 (nie zawiera źródła światła) / 230V | 1 x 15W (max)
- 180 (240 z adapterem) wys. | 130 szer. | 140 gł.
- 0,7
- IP 20
- w komplecie z adapterem umożliwiającym montaż do szyny/możliwość regulacji

NET NET PLUS

- 4312** - biały struktura, czarny struktura, czarny
- 4313** - szalwia struktura, czarny struktura, czarny
- 4314** - czarny struktura, el. mosiądzowane, czarny
- 4748** - błękit mat, czarny
- zwis 1 pt.
- 4312, 4313, 4748** - stal lakierowana, tworzywo sztuczne
4314 - stal lakierowana, el. mosiądzowane, tworzywo sztuczne
- E27 (nie zawiera źródła światła) / 230V | 1 x 15W (max)
- 990 (1050 z adapterem) wys. | 130 szer. | 140 gł.
- 0,85
- IP 20
- w komplecie z adapterem umożliwiającym montaż do szyny
UWAGA możliwość wyboru DŁUGOŚCI RURKI - 30 - 60 - 90 CM
- CENA standard; możliwość zmiany standardowej długości rurki - cena ustalana wówczas indywidualnie

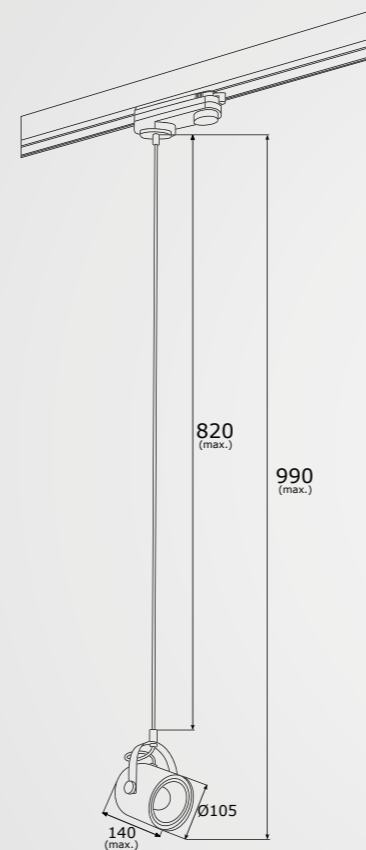

ARGON T-RACK SYSTEM

● czarny

Ⓜ IP 20

SZYNA 1 M

Ⓜ 4370 - aluminium

Ⓜ 35 wys. | 1000 szer. | 35 gł.

Ⓜ 1

⊕ szyna 3-obwodowa

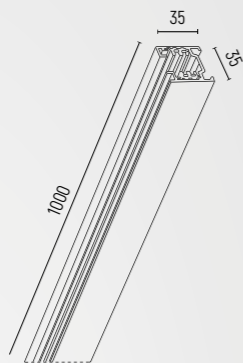

SZYNA 2 M

Ⓜ 4380 - aluminium

Ⓜ 35 wys. | 2000 szer. | 35 gł.

Ⓜ 2

⊕ szyna 3-obwodowa

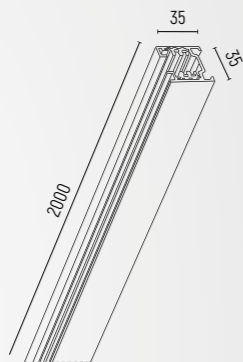

ŁĄCZNIK ŁAMANY

Ⓜ 4363 - tworzywo sztuczne

Ⓜ 35 wys. | 260 szer. | 35 gł.

Ⓜ 0,16

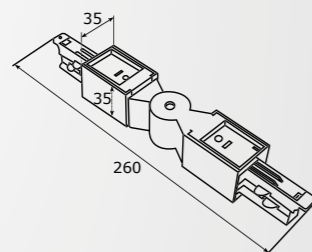

ŁĄCZNIK PROSTY

Ⓜ 4364 - tworzywo sztuczne

Ⓜ 35 wys. | 190 szer. | 35 gł.

Ⓜ 0,12

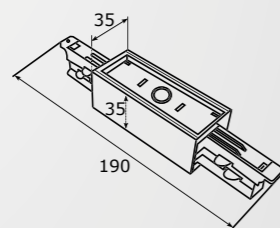

KOŃCÓWKA ZASILAJĄCA

Ⓜ 4366 - tworzywo sztuczne

Ⓜ 35 wys. | 115 szer. | 35 gł.

Ⓜ 0,06

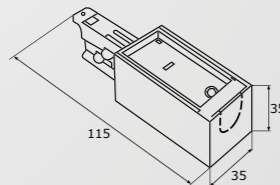

T-RACK SYSTEM 4370, 4380



T-RACK SYSTEM 4363



T-RACK SYSTEM 4364



T-RACK SYSTEM 4366



T-RACK SYSTEM 4367



T-RACK SYSTEM 4670



T-RACK SYSTEM 4369



T-RACK SYSTEM 8040



T-RACK SYSTEM 8041

ŁĄCZNIK L LEWY

Ⓜ 4367 - tworzywo sztuczne

Ⓜ 35 wys. | 110 szer. | 110 gł.

Ⓜ 0,12

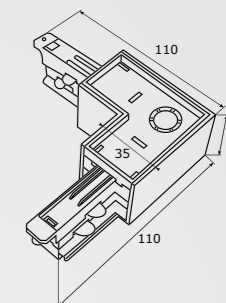

ŁĄCZNIK L PRAWY

Ⓜ 4670 - tworzywo sztuczne

Ⓜ 35 wys. | 110 szer. | 110 gł.

Ⓜ 0,12

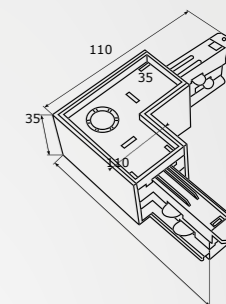

KOŃCÓWKA / ZAŚLEPKA

Ⓜ 4369 - tworzywo sztuczne

Ⓜ 35 wys. | 35 szer. | 20 gł.

Ⓜ 0,01

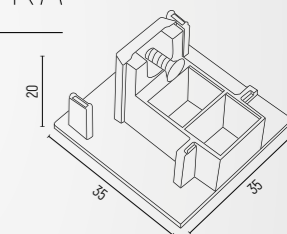

ŁĄCZNIK TYPU "T"

Ⓜ 8040 - tworzywo sztuczne

Ⓜ 32 wys. | 165 szer. | 100 gł.

Ⓜ 0,15

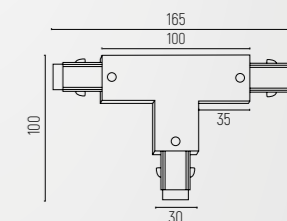

ŁĄCZNIK TYPU "X"

Ⓜ 8041 - tworzywo sztuczne

Ⓜ 32 wys. | 165 szer. | 165 gł.

Ⓜ 0,22

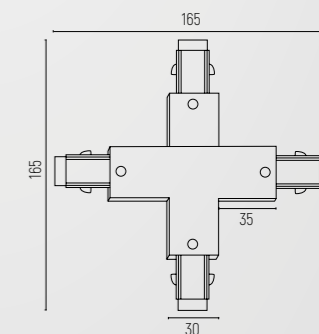

ALFABETYCZNY INDEKS RODZIN LAMP

ABBANO NEW	12	BODRUM	37	ETNA	61	LAGOS	80	ONTARIO LED	167	TENERYFA	139
ABRUZZO NEW	13	BOLZANO	38	ETNA PLUS NEW	60	LAGUNA	91	OPTICA	113	TOMAR	140
ABSTRACT	16	BOLZANO PLUS	38	EUFRAT	63	LATINA	92	OREGON	113	TONI	173
AKRON	16	BUFFALO	37	FARON	66	LILLE	93	ORTE NEW	114	TORRE NEW	140
ALMADA	17	BURGOS	41	FERRONE NEW	66	LINDOS	95	OVIEDO	152	TRINI	142
ALTEA	18	CADIZ	149	FLAVIO	65	LINEA	94	PALLADO NEW	144	TROY	141
ALTO	179	CALIGARI	42	FOTO NEW	67	LIRANO	95	PASADENA NEW	117	TUBO NEW	175
AMADORA	20	CALVADOS	43	FOXY	68	LIVIA	96	POLONIA NEW	119	TWIST NEW	124
AMALFI NEW	21	CALVIA	44	FREEMONT NEW	68	LORENA	97	PONTE	120	TYBER	176
AMARYLIS	22	CAMELOT	48	FUDŽI	71	LUKKA	98	PONTE PLUS	120	TYBER PLUS	175
AMAZONKA	22	CAMELOT PLUS NEW	47	GABIAN NEW	73	MAGIC	100	PORTORYKO	123	URAL	130
AMORE NEW	155	CAMERON	49	GARLAND	165	MARBELLA	102	PRATO	126	VALIANO NEW	145
ARGON T-RACK SYSTEM	184	CELIA	44	GIN	116	MARBELLA PLUS NEW	102	RAVELLO NEW	125	VENETO NEW	153
ARIZONA	156	CHARLOTTE NEW	50	GLEN	74	MASSETO NEW	104	RENO	128	VERMONT	177
ASPEN	23	CHICAGO	116	GOMERA	75	MASSIMO PLUS NEW	105	ROCK	169	VICHY	177
ASSE NEW	24	CLAVA	45	GOMERA PLUS	75	MEGAN	106	ROCKSTAR	169	ZAKYNTOS	146
ASTER	25	CLEVELAND	158	HERMAN	76	METIS	107	RODAN	172	ZAKYNTOS BIS	147
ASTI	26	CORSO	53	HILARY	77	MINORI NEW	104	RODOS	171	ZAKYNTOS PLUS NEW	146
ATLANTIS	157	CRUZ	150	HORTA	182	MITOS	108	RODOS PLUS	170		
AUSTIN	27	DARLING	159	IRUN	79	MOHITO	108	ROVETTO NEW	65		
AVALONE NEW	28	DARLING LED NEW	162	JACKSON	81	MORITZ	109	SAGUNTO	127		
AVILA PLUS NEW	31	DECORATO	43	JAMAJKA	80	MURANO NEW	106	SALADO	115		
BALTIMORE	31	DELFI	180	JASPER	165	MURI	182	SALERNO NEW	151		
BANG	179	DEPORTIVO	151	JESSE NEW	81	NANCY	110	SANDRINO PLUS NEW	128		
BEJA	32	DETROIT	58	KALIMERA	82	NASHVILLE	111	SANTANA	129		
BELLA	33	DORIA	55	KARIN	84	NET	183	SATELITE	131		
BERGEN	180	DOVER	57	KASER	86	NET PLUS	183	SATELITE PLUS NEW	130		
BERKLEY	33	ELBRUS	181	KONGO	89	NEWA	110	SEKWANA	133		
BEVERLY	34	ERBA	58	KOPERNIK	82	OAKLAND	112	SERAFINO	133		
BILBAO	149	ERBA BIS	59	KOS	88	OLIMP	166	SICILIA	135		
BILL	36	ESPRESSO	164	KOS PLUS NEW	87	OLIMP PLUS	166	SICILIA PLUS NEW	134		
						OMBRA NEW	115	SINES	136		
						ONTARIO	168	SKIATOS	139		



LAMPA MA ZNACZENIE

Dobranie oprawy oświetleniowej do wnętrza zależy przede wszystkim od potrzeb użytkownika, powierzchni pomieszczenia, stopnia dostępności do światła dziennego – naturalnego, jak również wystroju danego wnętrza. Dlatego warto zastanowić się na tych aspektach i pamiętać, że lampa to niezwykle ważna część składowa domu. Lampa to nie tylko światło, ale także element, który jest odpowiedzialny za dekorację pomieszczenia. Kupuj lampy ARGON u naszych dystrybutorów, którzy zawsze chętnie pomogą i doradzą w kwestii doboru właściwego oświetlenia. Lista dystrybutorów ARGON dostępna [na stronie](#).



CZAS REALIZACJI ZAMÓWIEŃ

Proces produkcyjny firmy ARGON odbywa się w siedzibie firmy, jak również przy współpracy z polskimi hutami szkła oraz dostawcami materiałów. W procesie produkcji korzystamy z różnych technologii oraz usług, ale nasze lampy to przede wszystkim praca wykonywana ręcznie przez pracowników ARGON oraz pozostałych współpracowników, co jest konieczne dla uzyskania efektu końcowego dobrej jakości. Wobec powyższego przeciętny czas oczekiwania na lampy ARGON to 5-20 dni roboczych, w zależności od obciążenia produkcyjnego czas ten może ulec skróceniu lub wydłużeniu.



ZAMÓWIENIA SPECJALNE

ARGON to producent oświetlenia, który umożliwia modyfikacje swoich lamp na etapie produkcji, a także podejmuje się wykonania produktów na zamówienia specjalne. Modyfikacje są możliwe po wcześniejszym zgłoszeniu

takiej chęci Działowi Sprzedaży i w zależności od możliwości produkcyjnych ARGON. Z uwagi na obciążenie produkcyjne niektóre modyfikacje mogą wydłużyć proces produkcyjny.

Zakres modyfikacji to między innymi:

- wydłużanie / skracanie przewodów, linek, łańcuchów, stelaży;
- zmiana przewodów np. z klasycznego na wersję oplot bawieñniany;
- włączanie opraw na np. dwie fazy;
- zmiana temperatury barwowej;
- zmiana zastosowanego koloru stelaża, podsufitki, el. przyściennego itp.;
- zainstalowanie włączników na oprawach;
- zmiana kształtu, rozmiaru zastosowanych podsufitek;
- zmiana wykończenia w zakresie lakierowania na chromowanie / mosiądzowanie i odwrotnie.

ARGON nie wyklucza innych modyfikacji niż wymienione powyżej, jednak są one wyceniane indywidualnie, po sprawdzeniu przez nas możliwości produkcyjnych.



CZY LAMPY ARGON ZAWIERAJĄ ŻARÓWKI

Lampy ARGON są standardowo sprzedawane bez źródeł światła, a informacja taka jest widoczna obok danego indeksu oprawy w katalogu (nie zawiera źródła światła). W innym przypadku, gdy oprawa zawiera jednak źródło światła (jest to wówczas preinstalowany moduł LED lub żarówka GU10 AR111), również taka adnotacja jest zamieszczona w katalogu (zawiera źródło światła). Zawsze także znajduje się informacja o maksymalnej mocy źródła światła jaką można zastosować w danej oprawie. Nie zalecamy stosować źródeł światła o mocy przewyższającej moc sugerowaną przez producenta.



TEMPERATURA BARWOWA ŹRÓDEŁ ŚWIATŁA LED W LAMPACH ARGON

Temperatura barwowa jest wyrażana w Kelwinach i określa barwę światła. Przyjmuje się, że światło ciepłe ma temperaturę barwową poniżej 3300 K, natomiast zimne – powyżej 5000 K – co oznacza, że im niżej skali tym światło cieplejsze. Standardowo źródła światła LED w lampach ARGON mają 3000 K, natomiast zawsze przy odpowiedniej adnotacji (podczas składania zamówienia do ARGON) możemy zastosować temperaturę barwową 4000 K. Przy zamówieniach na większą skalę jest możliwość zastosowania również innej temperatury barwowej, np. 2700 czy 4500. Podczas decyzji zakupowych warto zwrócić na to uwagę.



CE, czyli DEKLARACJA ZGODNOŚCI

Deklarujemy, że wszystkie wyroby ARGON znajdujące się w niniejszym katalogu, są testowane i posiadają Deklarację Zgodności. Na wyroby posiadające deklarację zgodności nakładane jest oznaczenie CE i zgodnie z powyższym: „Domniemywa się, że wyrób na którym umieszczono oznakowanie zgodności lub dla którego sporządzono dokumentację potwierdzającą spełnienie zasadniczych wymagań, jest zgodny z wymaganiami określonymi w obowiązujących przepisach”.



KLASA SZCZELNOŚCI LAMPY

Stopień szczelności to nic innego jak techniczne oznaczenie tego jak dana lampa, oprawa oświetleniowa (a także zegarek, telefon czy inny sprzęt) jest wytrzymała na czynniki takie jak woda, wilgoć, kurz, a nawet dotyk. Światowym standardem określania stopnia ochrony, klasy szczelności jest

kod IP, który zwykle składa się z dwóch liter kodu (IP) oraz dwóch cyfr, czasem też litery X, w niektórych przypadkach pojawiają się też dodatkowe uzupełniające litery. Lampy w ofercie firmy ARGON posiadają IP20 lub IP44.

IP20 – W przypadku tego stopnia ochrony oprawa oświetleniowa/lampa odporna jest na kontakt z ciałami stałymi o wielkości większej od 12,5 mm. Przypadkowe dotknięcie palcem takiej lampy nie zagraża niebezpieczeństwem ani uszkodzeniu elektrycznemu oprawy. Nie musimy się też martwić o to, że dostanie się do jej elementów elektrycznych owad. Lampy o IP20 są najpopularniejsze w ofercie firmy ARGON i jest to standard do użytku w pomieszczeniach o typowej wilgotności.

IP44 – lampy/oprawy oświetleniowe o stopniu ochrony IP44 są chronione przed obcymi ciałami stałymi o średnicy 1 mm lub większej. Przede wszystkim to gwarancja ochrony przed bryzgami wody z dowolnego kierunku. Oznacza to, że lampy z IP44 bezproblemowo radzą sobie w ogrodach, a także w łazienkach w miejscach, gdzie istnieje ryzyko kontaktu z wodą. Oczywiście nie są to oprawy, które miałyby cały czas być nastawione na działanie wody (np. pod ogrodową fontanną), jednak ryzyko ochlapania czy pracy tymczasowej w większej wilgotności nie są takim lampom groźne. W ofercie ARGON znajdują się także oprawy z IP44.



INSTRUKCJA UŻYTKOWANIA OPRAW ARGON

Montaż opraw, demontaż, przeglądy konserwacyjne itp. czy wszelkiego rodzaju naprawy związane z oprawą mogą być przeprowadzane tylko przez osoby posiadające wymagane kwalifikacje zgodnie z instrukcją montażu i wymaganiami bezpieczeństwa dotyczącymi opraw oświetleniowych. Wszelkie prace przeprowadzane przy oprawie muszą być wykonywane przy odłączonym zasilaniu sieciowym. Za każdym razem należy sprawdzić mocowanie oprawy oraz mocowanie źródła światła. Producent nie zaleca

stosowanie w oprawie źródeł światła o mocy wyższej niż podana na oprawie. Powierzchnie opraw należy czyścić miękką ściereczką (nie wolno stosować środków mogących zarysować powierzchnię lakierniczą). Przed czyszczeniem opraw należy bezwzględnie wyłączyć oraz pozwolić jej ostygnąć do temp. pokojowej. Szczegółowe informacje dot. użytkowania opraw oraz instrukcje montażu opraw ARGON dostępne są [na stronie](#).



GWARANCJA

Na lampy ARGON udzielana jest 2 letnia gwarancja (dot. obudowy oraz układu zasilającego) lub 5 letnia (dot. zintegrowanego źródła światła LED) licząc od daty sprzedaży.

Gwarancją objęte są wady produkcyjne oprawy oświetleniowej uniemożliwiającej jego użytkowanie zgodnie z przeznaczeniem. Gwarancja obejmuje wyłącznie wady powstałe z przyczyn tkwiących w towarze, tj. wady ukryte powstałe wskutek wad produkcyjnych lub ukrytych wad materiałowych. Warunkiem skorzystania z zapisów ogólnych warunków gwarancji jest posiadanie dowodu zakupu oraz wypełniona karta gwarancyjna. Szczegółowe informacje dot. gwarancji opraw oświetleniowych ARGON dostępne [na stronie](#).



UWAGA! URZĄDZENIA NIE WOLNO WRZUCAĆ DO ODPADÓW DOMOWYCH

Zużyte oprawy oświetleniowe są surowcami wtórnymi – nie wolno wyrzucać ich do pojemników na odpady domowe, mogą zawierać substancje niebezpieczne dla zdrowia i życia ludzkiego oraz środowiska. Zgodnie z dyrektywą WEEE 2012/19/UE użytkownik zobowiązany jest do oddania opraw do punktu zbierania zużytego sprzętu, co przyczyni się do ochrony środowiska naturalnego.



Zdjęcia prezentowanego asortymentu w niniejszym katalogu mają charakter poglądowy. Rzeczywisty kolor produktów może nieznacznie odbiegać od prezentowanego na zdjęciach, ze względu na technologię druku.

Rzeczywiste parametry produktów mogą się różnić od wartości deklarowanych w katalogu o +/- 10%.



Lista dystrybutorów ARGON dostępna [na stronie](#).



Modele 3D wybranych lamp ARGON dostępne [na stronie](#).

argon[®]

Ul. Szkolna 258, 42-261 Starcza

tel. +48 343140250, mobile: +48 517501688

biuro@argon-lampy.pl

www.argon-lampy.pl



www.argon-lampy.pl